



2-speed 3-phase motor starter Size 4 Two separate windings Constant or variable torque Solid-state overload relays Low SPD OLR range 50-200A High SPD OLR range 50-200A 110V 50HZ / 120V 60HZ coil Enclosure NEMA type (open) No enclosure

|   |                                       |
|---|---------------------------------------|
| product brand name  | Class 30                              |
| design of the product   | Full-voltage two speed motor starter  |
| special product feature   | ESP200 overload relay                 |
| <b>General technical data</b>   |                                       |
| weight [lb]   | 21 lb                                 |
| Height x Width x Depth [in]   | 11 × 12 × 6 in                        |
| touch protection against electrical shock                               | Not finger-safe                       |
| installation altitude [ft] at height above sea level maximum            | 6560 ft                               |
| ambient temperature [°F]  |                                       |
| • during storage  | -22 ... +149 °F                       |
| • during operation  | -4 ... +104 °F                        |
| ambient temperature   |                                       |
| • during storage  | -30 ... +65 °C                        |
| • during operation  | -20 ... +40 °C                        |
| country of origin   | Mexico                                |
| <b>Horsepower ratings</b>   |                                       |
| yielded mechanical performance [hp] for 3-phase AC motor                |                                       |
| • at 200/208 V rated value  | 40 hp                                 |
| • at 220/230 V rated value  | 50 hp                                 |
| • at 460/480 V rated value  | 100 hp                                |
| • at 575/600 V rated value  | 100 hp                                |
| <b>Contactors</b>   |                                       |
| size of contactor   | NEMA controller size 4                |
| number of NO contacts for main contacts                                 | 6                                     |
| operating voltage for main current circuit at AC at 60 Hz maximum       | 600 V                                 |
| operational current at AC at 600 V rated value                          | 135 A                                 |
| mechanical service life (operating cycles) of the main contacts typical | 5000000                               |
| <b>Auxiliary contact</b>  |                                       |
| number of NC contacts at contactor for auxiliary contacts               | 2                                     |
| number of NO contacts at contactor for auxiliary contacts               | 2                                     |
| number of total auxiliary contacts maximum                              | 7                                     |
| contact rating of auxiliary contacts of contactor according to UL       | 10A@600VAC (A600), 2.5A@300VDC (Q300) |
| <b>Coil</b>   |                                       |
| type of voltage of the control supply voltage                           | AC                                    |
| control supply voltage  |                                       |
| • at AC at 50 Hz rated value  | 110 V                                 |
| • at AC at 60 Hz rated value  | 120 V                                 |
| holding power at AC minimum   | 22 W                                  |
| apparent pick-up power of magnet coil at AC                             | 510 VA                                |

|  |              |
|--|--------------|
| apparent holding power of magnet coil at AC                              | 51 VA        |
| operating range factor control supply voltage rated value of magnet coil | 0 ... 1      |
| percentual drop-out voltage of magnet coil related to the input voltage  | 50 %         |
| ON-delay time  | 18 ... 34 ms |
| OFF-delay time   | 10 ... 12 ms |

### Overload relay

|  |   |
|--|---|
| product function   |   |
| <ul style="list-style-type: none"> <li>• overload protection</li> <li>• phase failure detection</li> <li>• asymmetry detection</li> <li>• ground fault detection</li> <li>• test function</li> <li>• external reset</li> </ul> | <ul style="list-style-type: none"> <li>Yes</li> <li>Yes</li> <li>Yes</li> <li>Yes</li> <li>Yes</li> <li>No</li> </ul> |
| reset function   | Manual, automatic and remote  |
| trip class   | CLASS 5 / 10 / 20 (factory set) / 30  |
| adjustable current response value current of overload relay  |   |
| <ul style="list-style-type: none"> <li>• for low rotational speed</li> <li>• for high rotational speed</li> </ul>  | <ul style="list-style-type: none"> <li>50 ... 200 A</li> <li>50 ... 200 A</li> </ul>                                  |
| tripping time at phase-loss maximum  | 3 s   |
| relative repeat accuracy   | 1 %   |
| product feature protective coating on printed-circuit board  | Yes   |
| number of NC contacts of auxiliary contacts of overload relay  | 1   |
| number of NO contacts of auxiliary contacts of overload relay  | 1   |
| operational current of auxiliary contacts of overload relay  |   |
| <ul style="list-style-type: none"> <li>• at AC at 600 V</li> <li>• at DC at 250 V</li> </ul>   | <ul style="list-style-type: none"> <li>5 A</li> <li>1 A</li> </ul>  |
| contact rating of auxiliary contacts of overload relay according to UL   | 5   |
| insulation voltage (Ui)  |   |
| <ul style="list-style-type: none"> <li>• with single-phase operation at AC rated value</li> <li>• with multi-phase operation at AC rated value</li> </ul>  | <ul style="list-style-type: none"> <li>600 V</li> <li>300 V</li> </ul>  |

### Mounting/wiring

|  |                                   |
|--|-----------------------------------|
| mounting position  | vertical                          |
| fastening method   | Surface mounting and installation |
| type of electrical connection for supply voltage line-side   | Box lug                           |
| tightening torque [lbf-in] for supply  | 200 ... 200 lbf-in                |
| type of connectable conductor cross-sections at line-side for AWG cables single or multi-stranded                        | 1                                 |
| temperature of the conductor for supply maximum permissible  | 75 °C                             |
| material of the conductor for supply   | CU                                |
| type of electrical connection for load-side outgoing feeder  | Box lug                           |
| tightening torque [lbf-in] for load-side outgoing feeder   | 200 ... 200 lbf-in                |
| type of connectable conductor cross-sections for AWG cables for load-side outgoing feeder single or multi-stranded       | 1                                 |
| temperature of the conductor for load-side outgoing feeder maximum permissible   | 75 °C                             |
| material of the conductor for load-side outgoing feeder  | CU                                |
| type of electrical connection of magnet coil   | Screw-type terminals              |
| tightening torque [lbf-in] at magnet coil  | 5 ... 12 lbf-in                   |
| type of connectable conductor cross-sections of magnet coil for AWG cables single or multi-stranded                      | 2                                 |
| temperature of the conductor at magnet coil maximum permissible  | 75 °C                             |
| material of the conductor at magnet coil   | CU                                |
| type of electrical connection for auxiliary contacts   | Screw-type terminals              |
| tightening torque [lbf-in] at contactor for auxiliary contacts   | 10 ... 15 lbf-in                  |
| type of connectable conductor cross-sections at contactor for AWG cables for auxiliary contacts single or multi-stranded | 1                                 |
| temperature of the conductor at contactor for auxiliary contacts maximum permissible                                     | 75 °C                             |
| material of the conductor at contactor for auxiliary contacts  | CU                                |
| type of electrical connection at overload relay for auxiliary  | Screw-type terminals              |

|   |                                     |
|---|-------------------------------------|
| contacts  |                                     |
| tightening torque [lbf-in] at overload relay for auxiliary contacts   | 7 ... 10 lbf-in                     |
| type of connectable conductor cross-sections at overload relay for AWG cables for auxiliary contacts single or multi-stranded | 2                                   |
| temperature of the conductor at overload relay for auxiliary contacts maximum permissible                                     | 75 °C                               |
| material of the conductor at overload relay for auxiliary contacts  | CU                                  |
| <b>Short-circuit current rating</b>   |                                     |
| design of the fuse link for short-circuit protection of the main circuit required   | 10                                  |
| design of the short-circuit trip  | Thermal magnetic circuit breaker    |
| maximum short-circuit current breaking capacity (Icu)   |                                     |
| • at 240 V  | 10 kA                               |
| • at 480 V  | 10 kA                               |
| • at 600 V  | 10 kA                               |
| certificate of suitability  | NEMA ICS 2; UL 508; CSA 22.2, No.14 |

**Further information**

Industrial Controls - Product Overview (Catalogs, Brochures,...)

[www.usa.siemens.com/iccatalog](http://www.usa.siemens.com/iccatalog)

Industry Mall (Online ordering system)

<https://mall.industry.siemens.com/mall/en/us/Catalog/product?mlfb=US2:30JUHH32A1VF>

Service&Support (Manuals, Certificates, Characteristics, FAQs,...)

<https://support.industry.siemens.com/cs/US/en/ps/US2:30JUHH32A1VF>

Image database (product images, 2D dimension drawings, 3D models, device circuit diagrams, EPLAN macros, ...)

[http://www.automation.siemens.com/bilddb/cax\\_de.aspx?mlfb=US2:30JUHH32A1VF&lang=en](http://www.automation.siemens.com/bilddb/cax_de.aspx?mlfb=US2:30JUHH32A1VF&lang=en)

Certificates/approvals

<https://support.industry.siemens.com/cs/US/en/ps/US2:30JUHH32A1VF/certificate>

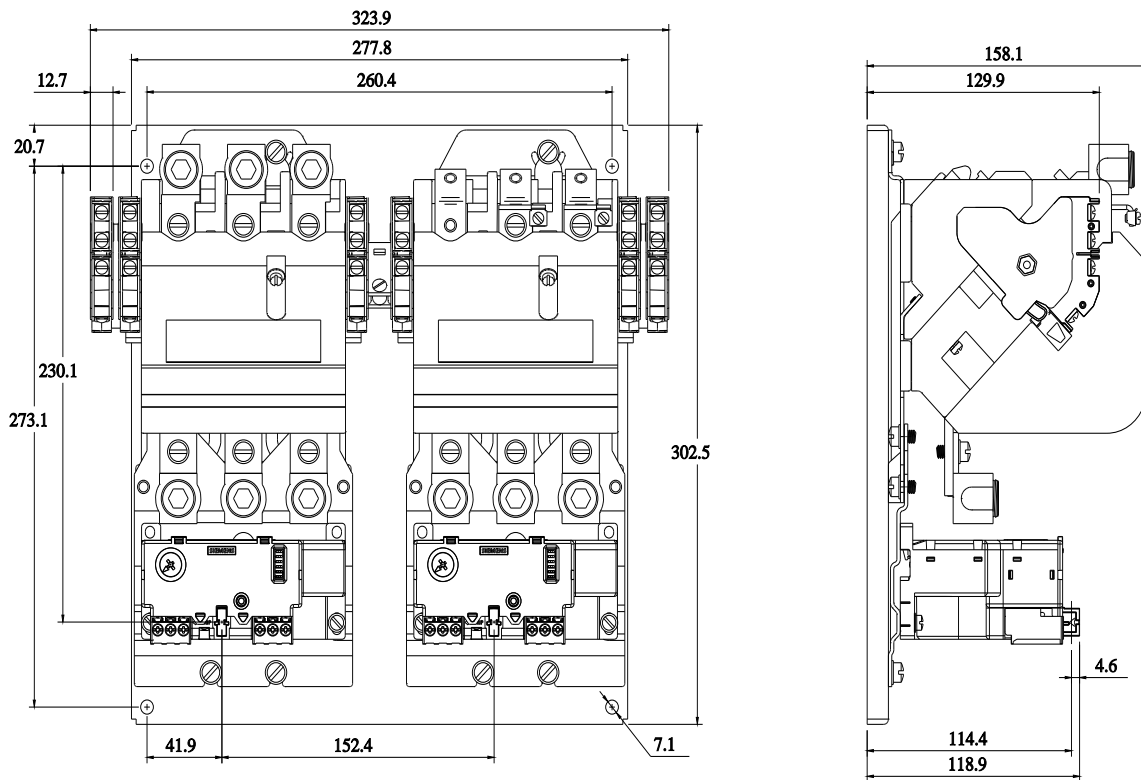

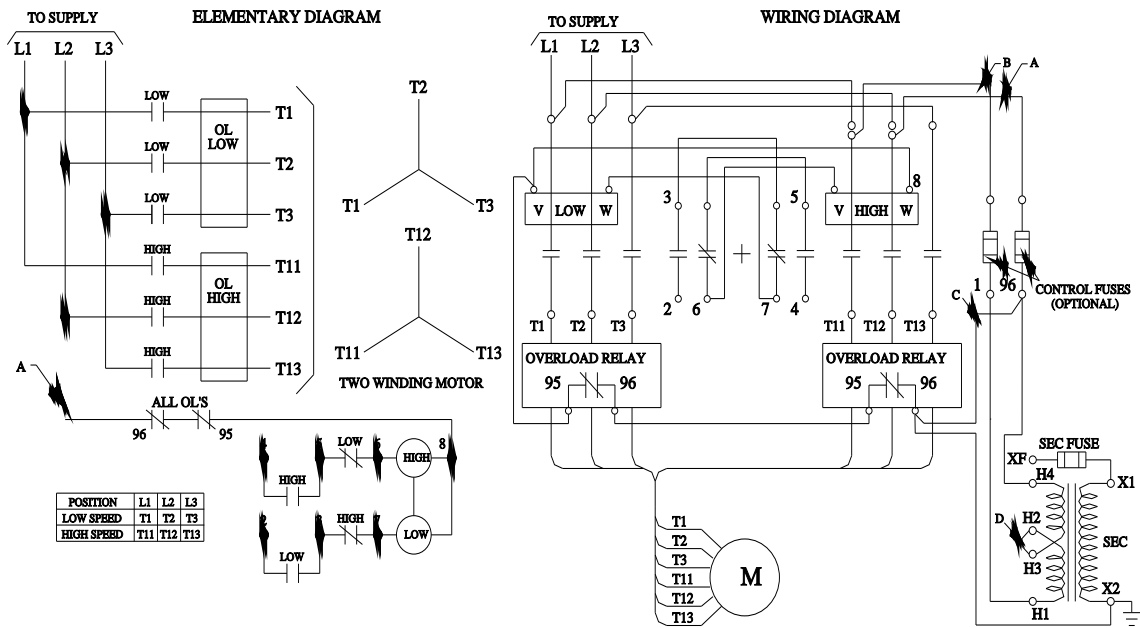

D46590008

last modified:

12/6/2023