

HMC3-M1614Y-V2

Quick Start Guide

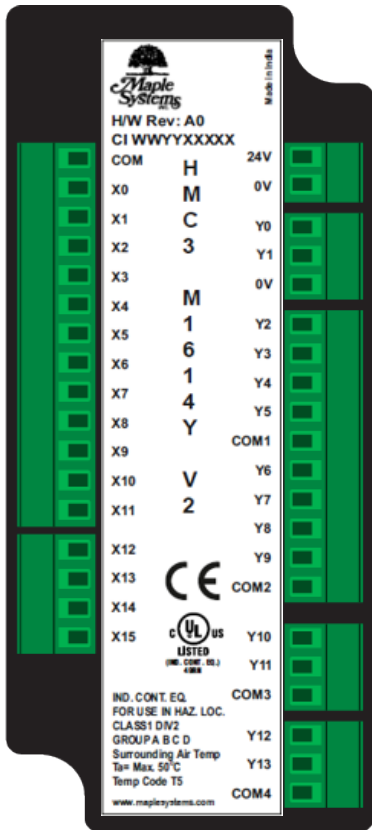

HMC3-M1614Y-V2: 16 Bi-directional type inputs, 2 high speed. 14 Digital outputs - 2 PNP type transistor outputs, 1 PWM and 12 Relay type outputs.

For more information, please refer to the MAPware-7000 Programming Manual, available in software help section and/or you can download from the Maple Systems website.



For More Information, visit
<https://www.maplesystems.com>

SPECIFICATIONS

Power Supply	
Voltage Rating	24VDC ($\pm 15\%$), 12V from base
Power Rating	Input/channel: 24VDC, 5mA typical Output/Channel: 250mA @ 24VDC
Isolation	Optical Isolation for all I/O points. High isolation voltage (BV= Greater than 1.5kV)
Local I/O Specification	
Number of Inputs	16 Inputs Bi-directional Type
Input Design	According to EN 61131-2 Type 1
ON Voltage	Min.: 15VDC, Max.: 30VDC
OFF Voltage	Min.: -3VDC, Max.: 5VDC
Nominal Input Voltage	24VDC
Nominal Input Current	5mA typical
Input Response Time	ON: 10msec, OFF: 10msec
Input Impedance	4.8k Ω
High Speed Inputs	2 pairs, X0-X1, X2-X3
Max Input Frequency	200kHz
Max Input Count	4,294,967,295 (32-bit)
Number of Outputs	2 PNP type transistor outputs and 12 Relay type outputs
ON Output Voltage	Min ON: 22VDC, Max. ON: 30VDC (Voltage across load)
OFF Output Voltage	Min OFF: 0.2VDC Max. OFF: 1VDC
Nominal Output Voltage	30VDC
Nominal Output Current	250mA type/channel, 2A @ 230VAC
Output Response Time	ON: 10msec, OFF: 10msec
Nominal Load Max.	96 Ω /6W (resistive) @ 24VDC 6VA (inductive, unity power factor)
High Speed Output (PWM)	1, Y0
Max. o/p frequency	1kHz
PWM Duty Cycle	0 to 100%
Analog I/O Specification	
Analog Input Total Channels	2 Input channels (16 bit resolution)
Input Type	0-20mA, 4-20mA & 0-10VDC, 0-5VDC
Analog Output Total Channels	1 Output channels (12 bit resolution)
Output type	0-20mA, 4-20mA and 0-10VDC, 0-5VDC
Accuracy	$\pm 0.2\%$ of full scale @ 25°C [Note: HMC3 I/O Module V2 Series only compatible with HMC2000/ HMC4000 Series Base Model]

SPECIFICATIONS

Environment & Approvals	
Operating Temperature**	0 to 60°C
Storage Temperature	-20 to 85°C
Humidity	10 to 90% (Non-Condensing)
Short Circuit Protection	Yes
Product Dimensions	48mm x 108mm x 35.7mm (W x H x D)
Approvals	CE, UL

** Operating temperature: For UL 0 to 50°C

Dimension Details

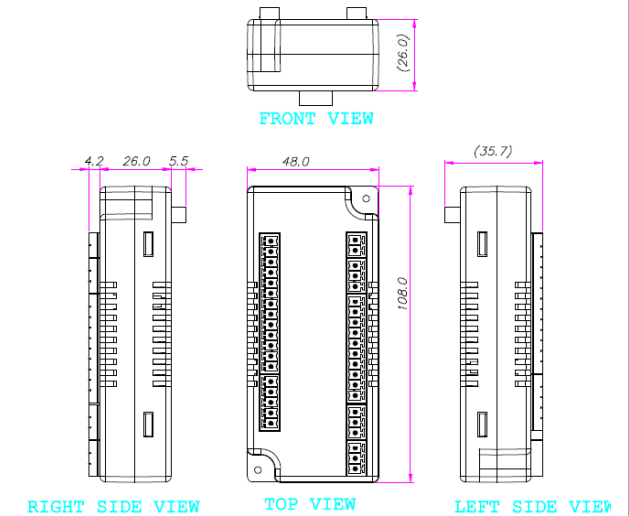

PANEL MOUNTING

Mounting with base models:

With the expansions, while unpacking the unit, user will find two screws already attached with base bottom case. Fix the expansion with the HMI as shown below with these screws. Fix the Expansion connector with the expansion female connector given on base HMI. Apply torque 0.1Nm while fixing with base unit.

Mounting with 4.3" base model:



Mounting with 10.1" base model:



[Note: All Pictures shown are for illustration purpose only. Actual product size may vary.]

Mounting with 7" and 10.1" base model:

For 7" and 10.1" HMI models, the procedure of mounting expansions is same. Only instead of horizontal mounting, expansions will mount in vertical directions.

Hence, accordingly these bases are having facility to add 3 and 5 expansions at a time respectively.

Examples are shown here.

Mounting with 7" base model:



WIRING DIAGRAM

Digital Inputs

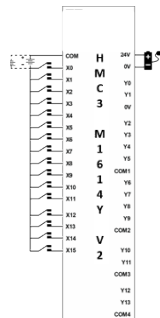

Digital Output

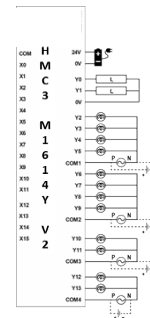

HSC Single Phase

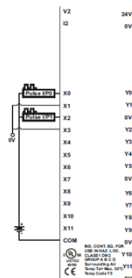

HSC Quadrature

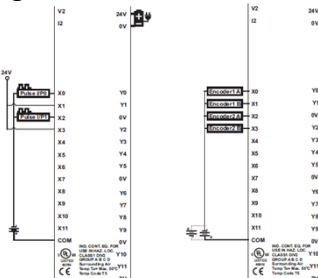

WARNING

- This equipment is suitable for use in Class I, Division 2, Groups A, B, C and D or non-hazardous locations only.
- WARNING – EXPLOSION HAZARD – Do not disconnect equipment unless power has been removed or the area is known to be non-hazardous.
- WARNING – EXPLOSION HAZARD - Substitution of components may impair suitability for Class I, Division 2.
- The list of materials used in the construction of these devices with name of sealed device - generic name of the material and the supplier's name and type designation.
- It is recommended that the user periodically inspect the sealed devices used, for any degradation of properties and replace the device if any degradation is found.

Technical Support:

- For Technical support, please contact Maple Systems along with the unit serial number and revision number written on the address sticker of the unit.
- Also, provide information of the application used. Usually, including your application also provides a lot of help. If possible, e-mail the application to Maple Systems.

REVISION HISTORY

Rev.	Description	Date
00	Initial Release	10/18/2022
01	Updated Release	04/18/2024

Maple Systems reserves the right to change or discontinue specifications and features without prior notice. To view the latest and updated datasheets/manuals please visit www.maplesystems.com.