

# EXPLOSION-PROOF DIFFERENTIAL PRESSURE SWITCH

Set points from 10 in w.c. to 200 psid, Rated 1500 psig, Weatherproof

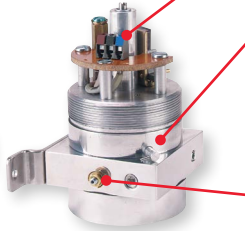

Shown without enclosure and cover

Internal terminal blocks for conductors up to 18 gage are optional

Optional NEMA 3 (IP54) enclosure includes explosion-proof drain; Standard NEMA 4X (IP56) version is without drain

External ground connection standard (internal ground connection also standard, use either one)

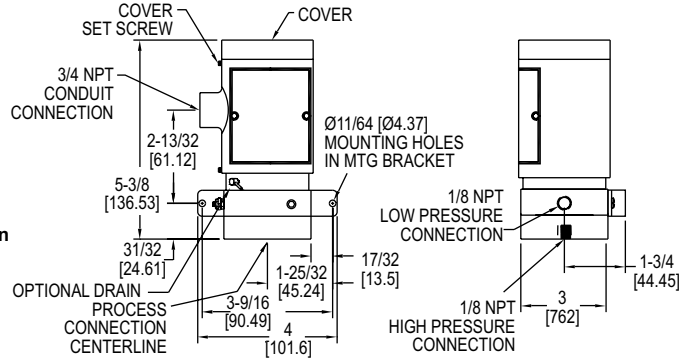

The Series H3 Explosion-Proof Differential Pressure Switch is a heavy duty, industrial unit with a unique new design which provides sensitivity to differential pressures as low as 10 inches of water (254 mm w.c.), yet handles total pressure of 1500 psi (103 bar). Unlike common differential pressure switches that use a piston-type motion transfer, the Series H3 utilizes a rotary motion transfer shaft that prevents a change in total pressure from causing a set point shift. Unit yields deadbands approximately 5% of range, with zero set point shift due to variation in working pressures. Friction is minimized and repeatability increased by allowing range spring to act directly on diaphragm plate. Rolling diaphragm design maintains constant effective area to further reduce friction. Diaphragm is allowed to "seat", allowing application of full rated pressure, up to 1500 psi (103 bar), on either high or low pressure port, without damage. Special over-travel feature prevents overtightening of range adjust screw. Choose optional 316 SS chamber for water and water-based fluids or harsher applications.

**BENEFITS/FEATURES**

- Rotary motion design prevents set point shifts
- Explosion-proof housing for use in applications where protection of process and personnel is needed
- Option for use with water and water-based solution makes this a versatile switch

**APPLICATIONS**

- Water flow proving with an orifice plate
- Differential pressure across chiller
- Liquid filter status

**SPECIFICATIONS**

**Wetted Materials:** See pressure chamber and diaphragm material in model chart.  
**Temperature Limit:** -4 to 220°F (-20 to 104°C), ATEX: -20 to 90°C (-4 to 194°F).  
**Pressure Limit:** 1500 psig (103 bar).  
**Enclosure Rating:** Standard meets NEMA 4X (IP56), drain option meets NEMA 3 (IP54). For hazardous use see the hazardous location ratings chart.  
**Switch Type:** SPDT or DPDT snap switch.  
**Electrical Rating:** 5 A @ 125/250 VAC, 30 VDC.  
**Electrical Connections:** See model chart.  
**Conduit Connection:** 3/4" female NPT.  
**Process Connection:** 1/8" female NPT.  
**Mounting Orientation:** Vertical.  
**Set Point Adjustment:** Internal screw.  
**Weight:** 4 lb 2 oz (2 kg).  
**Deadband:** Approximately 5% of range.  
**Compliance:** ATEX, CE, CSA, UL see ratings chart.

MODEL CHART							
Example	H3	S	-2	S	C	-MV	H3S-2SC-MV
Series	H3						Explosion-proof differential pressure switch
Pressure Chamber and Diaphragm Material (Wetted)		A S					Aluminum chamber with nitrile diaphragm 316 SS chamber with fluoroelastomer diaphragm
Adjustable Operating Range			1 2 3 4				10-180 in. w.c. (2.48-44.78 kPa) 0.5-15 psid (0.03-1 bar) 5-70 psid (.34-4.8 bar) 10-200 psid (.7-13.8 bar)
Circuit (Switch) Options				S D			SPDT snap action switch rated 5 A @ 125/250 VAC, 30 VDC DPDT snap action switch rated 5 A @ 125/250 VAC, 30 VDC
Electrical Connection					L T C		18 AWG x 18 inch lead wires UL, CSA approved internal terminal block ATEX approved internal terminal block
Options						Drain MV VIT	Enclosure with drain - allows condensate to be drained from inside (meets NEMA 3 instead of 4X) Gold contacts on snap switch for dry circuits rated 1 A @ 125 VAC, 1A resistive or 0.5 A inductive @ 30 VDC Fluoroelastomer diaphragm option where not standard

**ACCESSORIES**

Model	Description
A-610	Pipe mounting kit for 1-1/4 to 2" pipe

**HAZARDOUS LOCATION RATINGS**

Model	UL	CSA	Directive 2014/34/EU ATEX Compliant
H3 _ _ _ C	-	-	CE 2813 Ex II 2 G Ex d IIC T5 or T6 EC-Type Certificate No. KEMA 03ATEX 2584
H3 _ _ _ L	Cl. I, Gr.B, C and D Cl. II, Gr.E, F and G	Cl. I, Gr.B, C and D Cl. II, Gr.E, F and G	-
H3 _ _ _ T	Cl. I, Gr.B, C and D Cl. II, Gr.E, F and G	Cl. I, Gr.B, C and D Cl. II, Gr.E, F and G	-
H3 _ _ _ C-DRAIN	-	-	CE 2813 Ex II 2 G Ex d IIC T5 or T6 EC-Type Certificate No. KEMA 03ATEX 2584
H3 _ _ _ L-DRAIN	Cl. I, Gr.B, C and D Cl. II, Gr.E, F and G	-	-