



# Technical Data Sheet

## *OMICRON-VR*



**OMICRON-VR** monitors AC voltage of a system/equipment and protects it from overvoltage, undervoltage and phase failure issues. As well as it indicates the occurrence of faults with help of LED indications

### Special Features

- Compact size 17.5 mm
- True RMS measurement
- Under voltage protection
- Over voltage protection
- Phase unbalance protection
- Phase failure protection
- Phase incorrect sequence protection
- Neutral failure protection
- Adjustable Nominal voltage, Trip point, Trip time delay
- Onsite selection of VLL / VLN value based tripping
- Self powered
- 1CO, 1CO+1CO relay configuration
- LED indication for faults
- Disabling of Over & Under Voltage fault on site is possible

## Application

Motor protection, Server rooms, Control system

## Parameter Settings

1. Nominal AC Voltage ( Vn ) ( Variable )	3 Phase : L : 110-240 VLL / 63-138 VLN M : 381-388-415 VLL / 220-230-240 VLN H : 415-440-480 VLL / 240-254-277 VLN
	1 Phase : L : 58-63-110-120-127-138 VLN H : 220-230-240-254 VLN
2. Over Voltage Trip point	105-125% (Variable)
3. Under Voltage Trip point	75-95% (Variable)
4. Voltage Unbalance*	Trip point : 20% ( Fixed )
5. Phase Failure	Trip point : 70 % ( Fixed )
6. Hysteresis value	3% (Fixed) of Trip point
	3% (Fixed) of Vn for Unbalance
7. Trip delay	0-10 seconds variablefor Undervoltage, Over voltage and Unbalance Instant tripping for Phase reversal, Neutral fail and Phase fail conditions
8. Reset Delay	1 second (Fixed)
9. Power On Delay	Approx. 3 seconds (Fixed)

\* Note : Unbalance setting is not applicable in single phase model.

## Technical Specifications

### Input Voltage

Nominal Input Voltage (AC RMS) (Programmable on site)	3 Ph : L.V. : 110-240VLL (63-138VLN) : M.V. : 381-388-415VLL (220-230-240VLN) : H.V. : 415-440-480VLL (240-254-277VLN) 1 Ph : L.V. : 58-63-110-120-127-138VLN : H.V. : 220-230-240-254VLN
Max Continuous Input Voltage	127% of nominal value
Nominal Frequency	50 / 60 Hz
Input Voltage Burden Per Phase	< 2 VA approx
Input Voltage Burden Three Phase	< 4 VA approx

### Operating Measuring Ranges

Voltage Range	70...125% of nominal value
---------------	----------------------------

### Operating Reference condition

Reference Condition	23°C +/- 2°C
Input waveform	Sinusoidal (distortion factor 0.005)
Input Frequency	50 / 60 Hz ± 2%

### Accuracy

Tripping Accuracy	± 3% of Nominal Value ± 0.8 sec for Trip delay
-------------------	---

### Response Time

Less than 200 msec
--------------------

## Technical Specifications

### Applicable Standards

Safety	IEC 61010-1-2010
IP for water & dust	IEC60529
Pollution degree	2
Installation category	CAT III
High Voltage Test	2.2 kV AC, 50Hz for 1 minute between all Electrical circuits

### Environmental

Operating temperature	-10 to +55°C
Storage temperature	-25 to +70°C
Relative humidity	0...90% non condensing
Shock	15g in 3 planes
Vibration	10...55 Hz, 0.15mm amplitude
Enclosure	IP20 (front face only)

### Relay Contacts

Types of output	1CO, 1CO+1CO
Contact Ratings (Res. Load)	5A/250VAC/30VDC (resistive load)
Mechanical Endurance	1x10 <sup>7</sup> OPS
Electrical Endurance	1x10 <sup>5</sup> OPS

### Mechanical Attributes

Weight	80 gm Approx
--------	--------------

## Dimensions Details

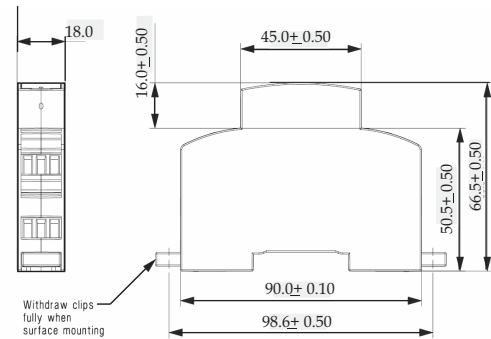

Withdraw clips fully when surface mounting

## Electrical Connection

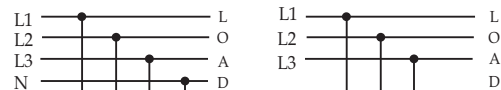

3 Phase 4 wire

3 Phase 3 wire

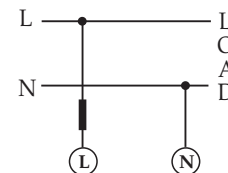

1 Phase 2 wire

## Terminal details

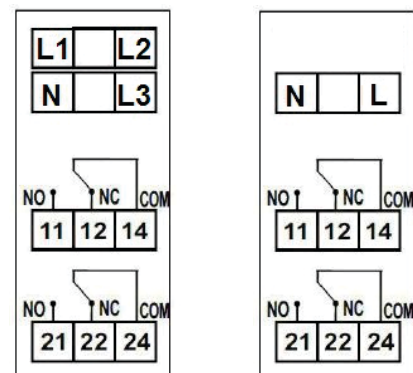

3 Phase

1 Phase

Note- Relay Contacts shown are in power off condition

All the dimensions are in mm.

LED indication table

LED indication	Continuous ON	Blinking
P-ON	Power ON	Incorrect Phase Sequence
UV/PF	Under Voltage	Phase Fail
OV	Over Voltage	-
UB/NF	UnBalance Voltage	Neutral Fail

## Ordering information

Product Code	PR10-	X	X	X	X	X	X	0	0	0	0	0ST
Model type for PR10	Voltage protection relay	V										
System Type for PR10	1P		1									
	3P		3									
System Voltage for PR10	110-240VLL (3PH ONLY)			1								
	381-415VLL (3PH ONLY)			7								
	415-480VLL (3PH ONLY)			6								
	58-138VLN (1PH ONLY)			5								
	220-254VLN (1PH ONLY)			8								
System Freq for PR10	Not applicable				0							
Relay Configuration for PR10	Normally Energized					1						
No. of Relay for PR10	1 relay						1					
	2 relay						2					
Reserved								0	0	0	0	0ST



**Sifam Tinsley Instrumentation Inc.**  
3105, Creekside Village Drive,  
Suite No. 801, Kennesaw,  
GA 30144 (USA)  
**E-mail Id :** psk@sifamtinsley.com  
**Web :** www.sifamtinsley.com  
**Contact No. :** +1 404 736 4903

**Sifam Tinsley Instrumentation Ltd**  
Unit 1 Warner Drive,  
Springwood Industrial Estate  
Braintree, Essex, UK, CM72YW  
**E-mail:** sales@sifamtinsley.com  
**Web:** www.sifamtinsley.com/uk  
**Contact:** +44(0)1803615139