

LFR(S)-/LR(S)-/LF(M.../X)----D

Filter regulator, Pressure regulator, Filter

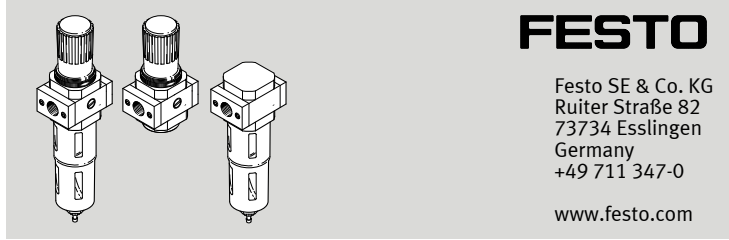

FESTO

Festo SE & Co. KG
Rüter Straße 82
73734 Esslingen
Germany
+49 711 347-0

www.festo.com

Instructions | Operating

8121613
2019-11k
[8121615]



Translation of the original instructions

© 2019 all rights reserved to Festo SE & Co. KG

1 Further applicable documents



All available documents for the product → www.festo.com/pk.

2 Safety

2.1 Safety instructions

- Only use the product in original status without unauthorised modifications.
- Only use the product if it is in perfect technical condition.
- Observe labelling on the product.
- Take into consideration the ambient conditions at the location of use.
- Prior to mounting, installation and maintenance work: Switch off compressed air supply and secure it from being switched back on.
- Observe tightening torques. Unless otherwise specified, the tolerance is $\pm 20\%$.

2.2 Intended Use

Type	Product	Intended Use
LFR(S)----D-MINI/MIDI/MAXI	Filter regulator	<ul style="list-style-type: none"> – Regulates the compressed air in the subsequent string to the set outlet pressure p_2. – Smooths out pressure fluctuations. – Removes dirt particles and condensate from the compressed air.
LR(S)----D-MINI/MIDI/MAXI	Pressure control valve	<ul style="list-style-type: none"> – Regulates the compressed air in the subsequent string to the set outlet pressure p_2. – Smooths out pressure fluctuations.
LF-...-D-MINI/MIDI/MAXI	Filter	Removes dirt particles and condensate from the compressed air.
LFMA-...-D-MINI/MIDI/MAXI	Micro filter (0.01 μm)	Removes dirt particles and oil drops from the compressed air.
LFMB-...-D-MINI/MIDI/MAXI	Fine filter (1 μm)	Removes dirt particles and oil drops from the compressed air.
LFX-...-D-MINI/MIDI/MAXI	Active carbon filter	Removes gaseous oil components from the compressed air.

Tab. 1 Intended Use

2.3 Training of Qualified Personnel

Installation, commissioning, maintenance and disassembly should only be conducted by qualified personnel.

The skilled personnel must be familiar with the installation of pneumatic control systems.

3 Further information

- Accessories → www.festo.com/catalogue.
- Spare parts → www.festo.com/spareparts.

4 Service

Contact your regional Festo contact person if you have technical questions → www.festo.com.

5 Product Design

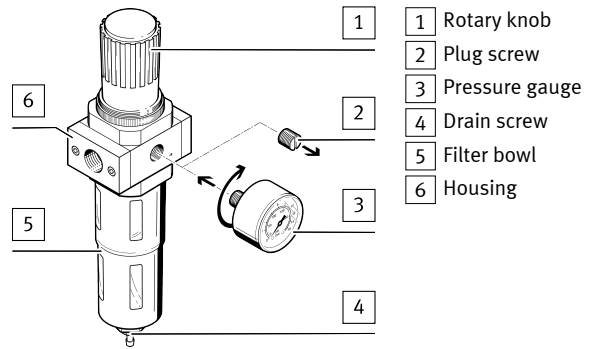

Fig. 1 Product design of filter regulator LFR(S)

6 Mounting

6.1 Mounting Clearances

- Maintain sufficient space around the product.
 - Space required above the product: 80 mm
 - Space required under the product: 90 mm
 - Space required left and right of the product: 90 mm

6.2 Preparation

1. Observe the mounting position → 13 Technical Data.
2. Note the flow direction of flow as shown by the numbers on the housing [6]: from 1 to 2.
3. Mounting accessories: → www.festo.com/catalogue.

6.3 Assembly of a Filter Combination

- Observe the sequence along the flow direction.
 - Fine filter LFMB (1 μm), micro filter LFMA (0.01 μm), active carbon filter LFX.

6.4 Mounting the Pressure Gauge PAGN

1. LFR(S)/LR(S)----O:
 - Remove the plug screw [2] on the pressure gauge connection or on the alternative connection on the back of the device.
 LFR(S)/LR(S) with pressure gauge in scope of delivery:
 - When using an alternative connection on the back of the device: use a plug screw.
2. Turn pressure gauge [3] clockwise to the stop. The pressure gauge seal is pre-assembled on the threaded connection journal. To align the pressure gauge, the pressure gauge can be turned back by a maximum of one rotation.

6.5 Assembly

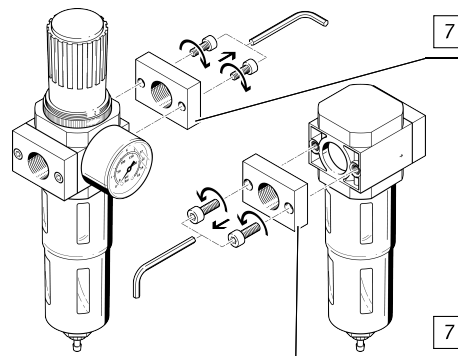

[7] Sub-base

Fig. 2 LFR(S)/LR(S)

1. If available: remove sub-base [7] from both add-on products on the sides to be fitted together.

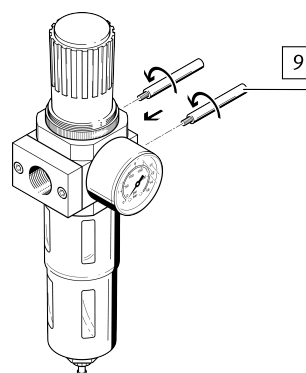

[9] Threaded bolt

Fig. 3 LFR(S)

- Screw in threaded bolt FRB-D [9]. Tightening torque: 2.5 – 0.5 Nm

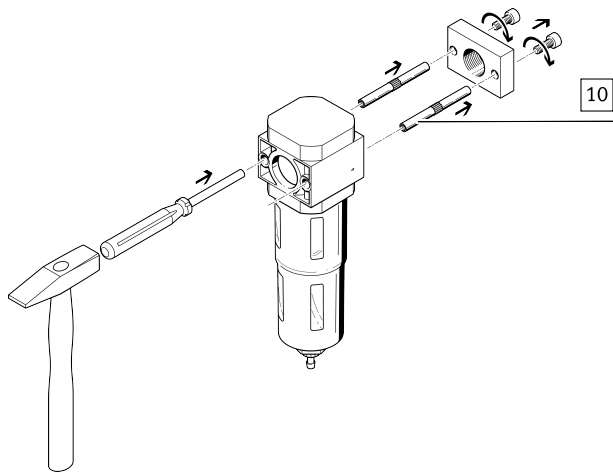

10 Spacer bolts

Fig. 4 LR(S)

- Remove the sub-base on the respective add-on product. Drive out the corresponding spacer bolts [10]. Driving action in flow direction.

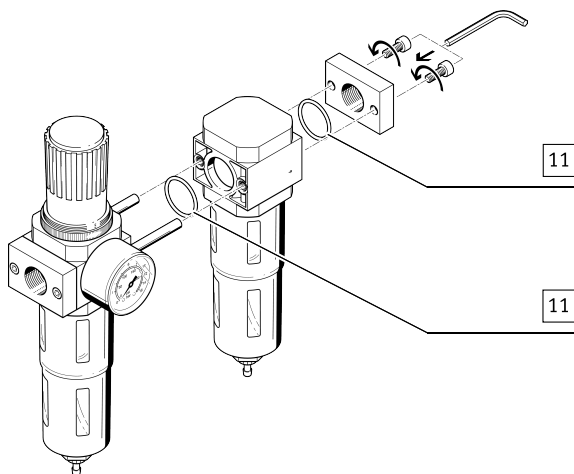

11 Seal

Fig. 5 LFR(S)/LR(S)

- Mount the add-on product with the sub-base. There must be one seal [11] each between the add-on products and the sub-base.

7 Pneumatic Installation

- Fittings, seals, suitable hoses: accessories → www.festo.com/catalogue.
- Screw fittings into the pneumatic ports.
- Push suitable hoses into the fitting up to the stop.
 - Position hoses axial to the pneumatic ports.
 - Do not exceed the minimum bending radius for the hoses.

8 Setting the Outlet Pressure

- Unlock rotary knob [1] (pull).
- Turn the rotary knob completely in the – direction.
- Exhaust system slowly: turn the rotary knob in the + direction until the desired pressure is reached.

Maintain permissible pressure regulation range → 13 Technical Data.
The input pressure p1 should always be at least 1 bar higher than the set outlet pressure p2.
- Lock the rotary knob [1].

9 Maintenance

9.1 Draining the Condensate

Manually Draining the Condensate

If the condensate reaches a level approx. 10 mm below the filter element:

- Turn drain screw [4] anticlockwise as seen from below.
 - The condensate flows out.
- Turn drain screw clockwise as seen from below.

Automatic Draining of the Condensate LFR(S)/LF...-A

The filter drains automatically.

9.2 Changing the Filter

- Unscrew the filter bowl [5].
- Disassemble the old filter cartridge:
 - LFR(S)/LF: unscrew the filter plate and remove the filter cartridge.
 - LFM.../LFX: unscrew the filter cartridge.
- Install new filter cartridge:
 - LFR(S)/LF: place filter cartridge on the filter plate. Screw filter plate in until it stops.
 - LFM.../LFX: hold filter cartridge at the bottom. Screw filter cartridge in until it stops.
- Screw in filter bowl. Tightening torque: MINI: 2 Nm, MIDI/MAXI: 2.5 Nm.

9.3 Cleaning

- Clean the outside of the product as required with a soft cloth.

Permissible cleaning agents:

 - Soap suds (max. +60 °C)
 - Petroleum ether (free of aromatic compounds)

10 Fault Clearance

Error description	Cause	Remedy
Low flow rate (operating pressure breaks down with air consumption)	Constriction in the supply line	Check supply line
	Filter cartridge is dirty	Replace filter cartridge → 9 Maintenance.
Pressure increases above the set working pressure	Valve disc defective at sealing seat	Replace product
Audible, continuous blowing noise at rotary knob	Valve seat damaged	Replace product
Blowing noise can be heard at the drain screw.	Drain screw leaking	Replace product or filter bowl

Tab. 2 Fault Clearance

11 Disassembly

- Exhaust the complete system and product.
- Release interlock at the fittings by pressing it and pull out hose assembly.
- Release fittings at the connecting flanges and unscrew.

12 Disposal

ENVIRONMENT!

Send the packaging and product for environmentally sound recycling in accordance with the current regulations → www.festo.com/sp.

13 Technical Data

Product	LFR(S)	LR(S)	LF	LFM	LFX
Mounting position	[°] Vertical +/-5				
Temperature ranges					
Temperature of medium	[°C] -10 ... +60			1.5 ... 60	5 ... 30
Ambient temperature	[°C] -10 ... +60				
Operating medium					
Compressed air to ISO 8573-1:2010	[-:9:-]			[6:8:4]	[1:4:2]
Input pressure					
Without fully automatic condensate drain	[MPa]	≤ 1.6			
	[bar]	≤ 16			
	[psi]	≤ 232			
With fully automatic condensate drain	[MPa]	0.2 ... 1.2			
	[bar]	2 ... 12			
	[psi]	29 ... 174			
Pressure regulation range					
For LFR(S)/LR(S)-...-D-7	[MPa]	0.05 ... 0.7			
	[bar]	0.5 ... 7			
	[psi]	7 ... 101			
For LFR(S)/LR(S)-...-D	[MPa]	0.05 ... 1.2			
	[bar]	0.5 ... 12			
	[psi]	7 ... 174			

Tab. 3 Technical Data



Replace the filter cartridge if the flow rate is reduced even though the pressure setting is unchanged.

- Exhaust compressed air from the product.