

RoHS and Reach Compliant

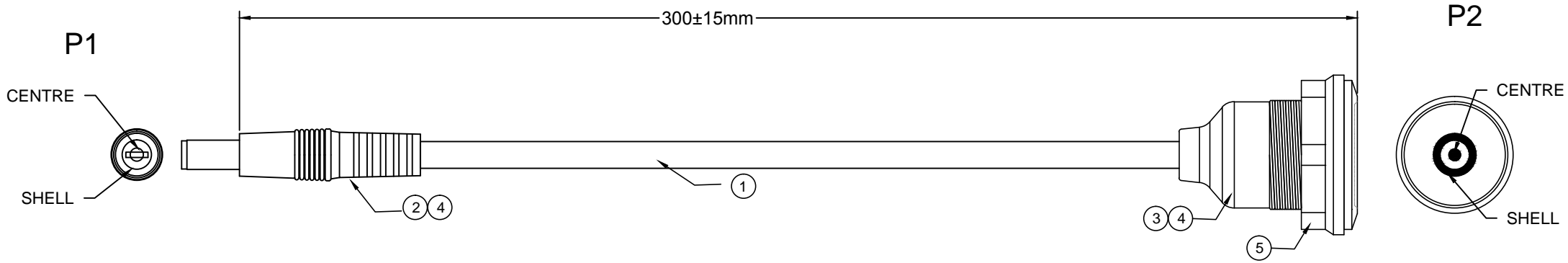

PIN ASSIGNMENT

P1	P2
CENTRE-----	CENTRE(RED)
SHELL-----	SHELL(BLACK)

NOTES:

1. PIN ASSIGNMENT SEE TO WIRE LIST.
2. ELECTRICAL TEST CONDITION:
 - (a). 100% OPEN, SHORT & MISWIRE TEST,
 - (b). INSULATOR RESISTANCE: 10 Mohm MIN.
DC 300V 0.01sec.
 - (c). CONTACT RESISTANCE: 3ohm MAX.

5	NUT BLACK PVC 27P MOLDED.	
4	OVERMOLD BLACK PVC 45P MA-001.	
3	DC5521 JACK WITH NICKLE PLATED BRASS.	
2	DC5521 PLUG WITH NICKLE PLATED BRASS.	
1	UL2464 20AWG*2C+AE OD:4.6MM BLACK PVC JACKE.	
NO.	Description	P/N

DWG NO:	PCM-0384	GOODS CODE		Draw		Date	2022/7/23
ITEM NO.		DRAWING EVIDENCE		Check		Date	
Goods NO.				Approval		Date	
Original NO.		Unit(mm)					

PREMIER CABLE MFG CO LTD

D		
C		
B		
VER.A	REVISE	Date.