

TOSHIBA
Leading Innovation >>>

Variable Speed Drive

TOSVERT VF-AS3



High-performance Drive TOSVERT VF-AS3

Variable Speed Drive for Industry

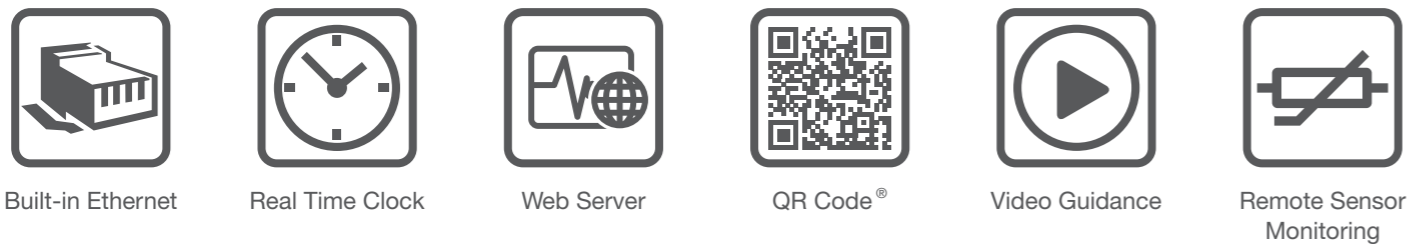

Built-in Ethernet Real Time Clock Web Server QR Code® Video Guidance Remote Sensor Monitoring

IoT / Industry 4.0 Ready

The high performance TOSHIBA VF-AS3 achieves high speed/real time network communication via embedded Ethernet without any optional devices, ready to meet the requirement of modern automation with IoT and Industry 4.0.

Also, VF-AS3 with TOSHIBA excellent motor control technology and hardware design helps for all your applications.



Voltage class	Applicable motor capacity (kW) : Multi ratings																										
	HD	0.4	0.75	1.5	2.2	4	5.5	7.5	11	15	18.5	22	30	37	45	55	75	90	110	132	160	200	220	280			
	ND	0.75	1.5	2.2	4	5.5	7.5	11	15	18.5	22	30	37	45	55	75	90	110	132	160	200	220	280	315			
3ph-240V class (IP20/IP00)		A1			A2		A3		A4			A5			A6												
3ph-480V class (IP20/IP00)		A1				A2				A3				A4				A5				A6		A7		A8	
3ph-480V class (IP55)		A1E				A2E				A3E				A4E				A5E									

*A1 to A8 and A1E to A5E show frame size of the drives

Contents

Evolution to IoT-Ready drive.....	P3	Standard specifications	P10	For drive users.....	P19
Ideal for various applications.....	P5	External dimensions	P15	Peripheral devices.....	P23
All-in-One. Improvement in Usability.....	P7	Standard connection diagrams	P17	Insert type options.....	P24
Basic functions	P9	Terminal functions	P18	Totally enclosed box type for IP55	P34

Evolution to IoT-Ready drive.

The VF-AS3 is an IoT-Ready variable speed drive. Using Internet, the VF-AS3 provides various solutions to you.



Built-in Dual Ethernet Port

The VF-AS3 has an embedded Ethernet dual port adaptor that can be used in the following Modbus TCP. The adaptor provides a set of services at the Ethernet and TCP/IP level.

The dual Ethernet port adaptor offers an embedded Web server which offers comfortable displaying and commissioning functions directly from a standard web browser.

The VF-AS3 supports the following Automatic IP address assignment via BOOTP and DHCP and Diagnostics and configuration via integrated Web server.

Remote Sensor Monitoring

The sensor which is equipped in the machine and equipment, can be connected with VF-AS3 and the status can be monitored by network communication.

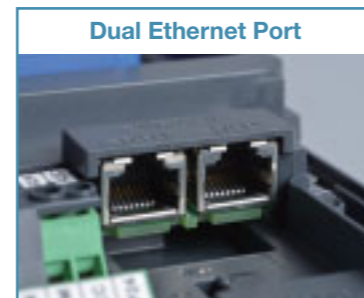

Web Server

The VF-AS3 has an embedded Web Server function, and it can be easily accessed and manage the operating condition remotely from your PC or Smart Phone/tablet devices. It can be monitored by standard web browser without any special software.

The widgets can be customized easily. The integrated web server is ideally suited for applications in which no special software or version dependencies are desired.

The product supports the following functions on Web server:

- Drive monitor
- Drive parameters read/write
- Trip history viewer
- Network parameter setting
- Administration function
- TCP/IP statistics monitor



QR Code®

For the advanced information and the event of drive fault, VF-AS3 displays the QR Code®(1), which will provide immediate access to a dedicated web link for support and maintenance.

(1) QR Code® is registered trademarks of DENSO WAVE INCORPORATED

Video Guidance

For the installation, setup and maintenance, the video guidance is available with web support.

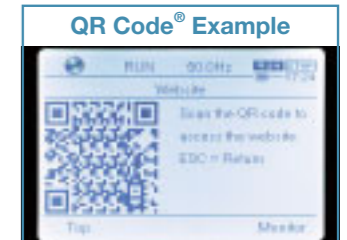

Real Time Clock - Calendar/Time Stamp function

The VF-AS3 has RTC (Real Time Clock) built-in. The calendar (work day, holiday, etc.) can be easily set by parameters.

Output terminal signal is ON at the day of the week, hour and minute set as "work day-time" by parameters.

The output terminal signal can be used as machine operation, pattern operation, and my function in the drive.

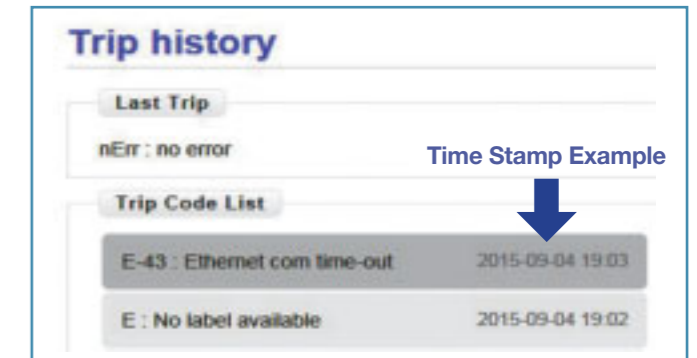

IoT Systems Solution

-Ideal for Plant & Process Control Application

The VF-AS3 can be connected with various devices through local area network, wireless network, and the Internet. It achieves data collection to know operational status and analyze system failure.

This IoT-Ready function increase productivity and reduce total cost.

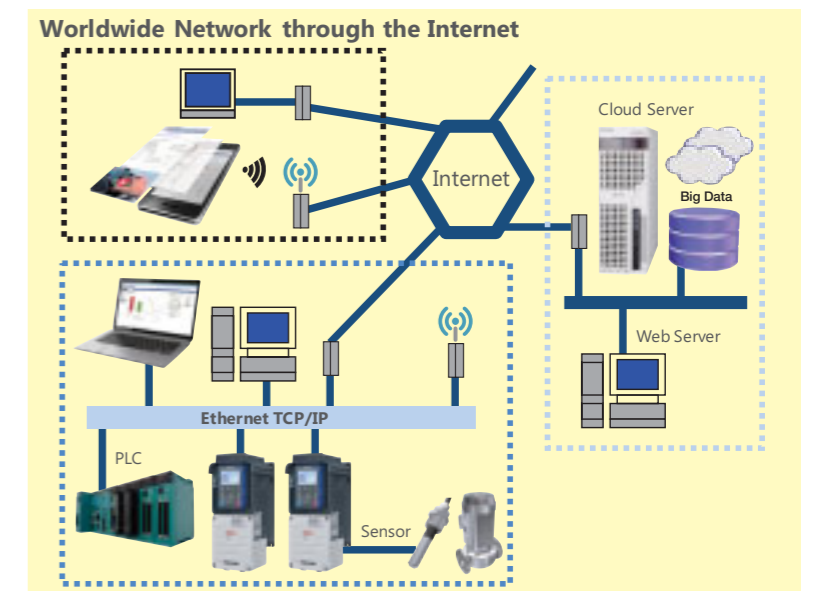
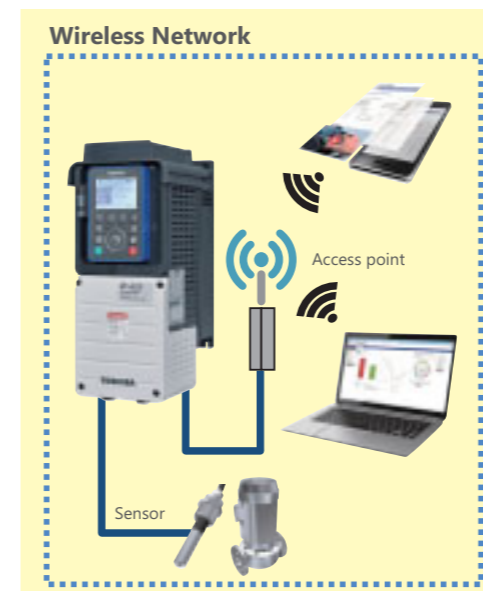
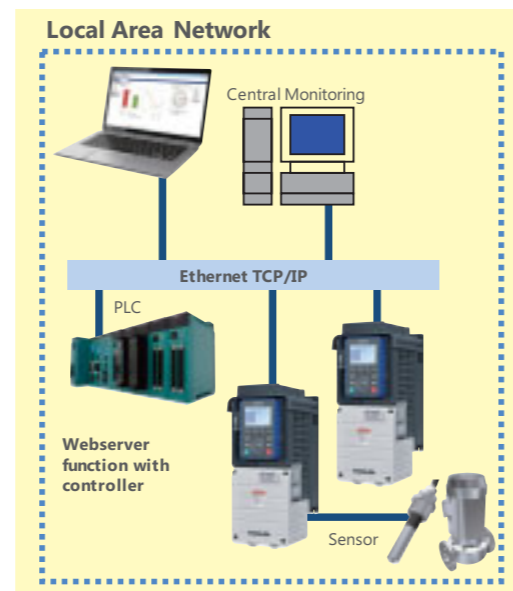

Ideal for various applications.

The VF-AS3 has various functions dedicated to various applications. The VF-AS3 will be the ideal choice for a wide variety of uses.

For Oil & Gas / Mining Industry

Jack pumps / Compressor / Conveyor / Crushers / Compressor

Multi ratings – excellent motor control performance

The VF-AS3 has the multi ratings and can drive for various application with HD(150%-60sec) and ND(120%-60sec). It is available for both heavy-load application and light-load application.

The starting torque with sensor-less vector control is 200% with 0.3Hz or more. The VF-AS3 achieves high starting torque and high accuracy regenerative torque at low frequency.

Easy to set up with Auto-tuning function

The VF-AS3 has the Auto-tuning function that automatically optimizes the drive parameters.

The moment of inertia of machine and equipment can also be set easily by Auto-tuning function.

PM motor drive

PM motor drive technology has been implemented in VF-AS3 as a standard feature. The VF-AS3 can control both induction and permanent magnetic synchronous motors with/without feedback sensor, allowing them to use for the variety of purposes.

The VF-AS3 can drive both interior permanent magnetic motor (IPM) and surface permanent magnetic motor (SPM)

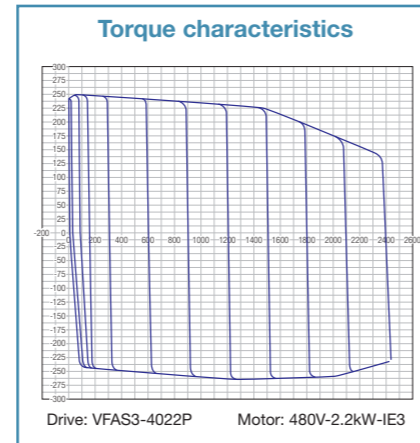

For Water & Wastewater Industry

Fan / Pump / Centrifuges

Multi pump control – maximum 10 pumps

The VF-AS3 can drive multiple pump motors (maximum ten pumps) and save the power of water pump system by controlling each pump appropriately, realizing great cost reduction.

Each pump is connected to commercial power via magnetic contactor which is controlled by relay output signal of the drive.

There are 3 relay output terminals on the drive. Furthermore, two I/O extensions can be inserted to the drive. Each I/O extension has 3 relay output terminals, and thus a maximum of 9 relay output terminals can be used.

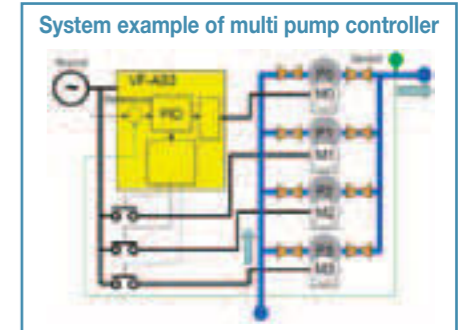

Space-saving and cost reduction by four embedded PID controllers

VF-AS3 has four built-in PID controllers: two for drives (motors) and other two for other devices including heaters and valves. The built-in PID controllers are available at the same time for many purposes. It can help reduce cost and space because it can omit additional external PID controllers.

The PID functions include temperature or pressure control of fan and pump, speed control of a winder, stop position control, etc.

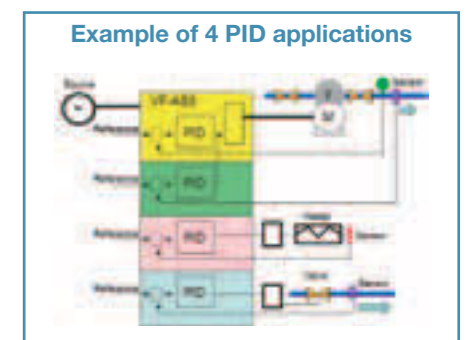

For Conveyor / Crane Industry

Transportation machine / Conveyor / Crushers / Compressor

Embedded positioning control

VF-AS3 has sensor / sensor-less position control with point to point, Pulse input and Orientation, which is suitable for applications such as processing machine for high precision control.

Excellent flexibility by My Function (logic function)

My function adds programming capability to the drive's input/output signals without external relays or PLC (programmable logic controller). The function makes it possible to reduce the space and cost required for the system.

My function has the relay sequence function that combines logic operation functions. The relay sequence function enables the drive to perform itself in 52 steps (4 steps x 7 units + 24 steps) without PLC. The processing speed is faster than control with PLC as the function uses internal data and signals directly.



For Chemical / Pharmaceutical Industry

Pumps / Mixers / Compressor / Centrifuges / Fans

Enhanced environment resistance

- Comply with the chemicals (3C3)/dust (3S3) standards of IEC60721-3-3. (Frame size A6 or smaller)
- Can be used at an altitude of up to 4800 m. (Frame size A6 or smaller)
- The inverter is operable at an ambient temperature of -15 to +60°C.
- The design expectancy life time of the cooling fan, smoothing aluminum electrolytic capacitor for power circuit, and aluminum electrolytic capacitor for control circuit are ten years.

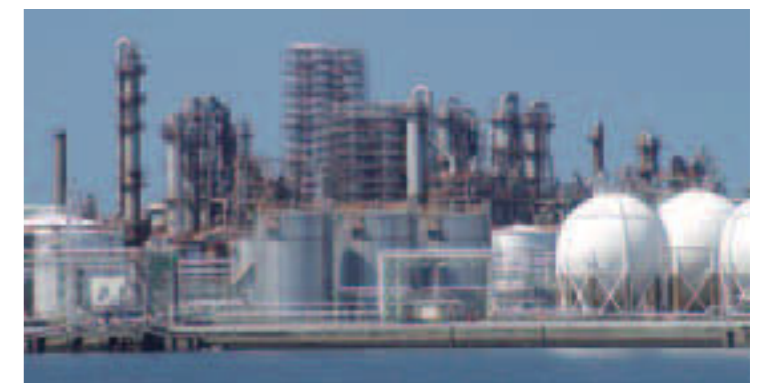

All-in-One. Improvement in Usability.

The VF-AS3 allows various functions without external options.
The VF-AS3 realizes improvement in usability and cost reduction.
Not necessary to prepare optional devices separately.

Reliable safety function

The VF-AS3 has STO (Safe Torque Off) function as standard and is highly reliable to cut off output in an emergency.

The STO function brings the machine safely into a no-torque state and prevents it from starting accidentally.

It complies with safety standard IEC 61800-5-2 and also achieves SIL3 level in IEC 61508 : 2010.

In addition, the following safety functions are available as options:

- SS1 (Safe Stop 1)
- SOS (Safe Operating Stop)
- SS2 (Safe Stop 2)
- SBC (Safe Brake Control)
- SLS (Safely-Limited Speed)
- SDI (Safe Direction)

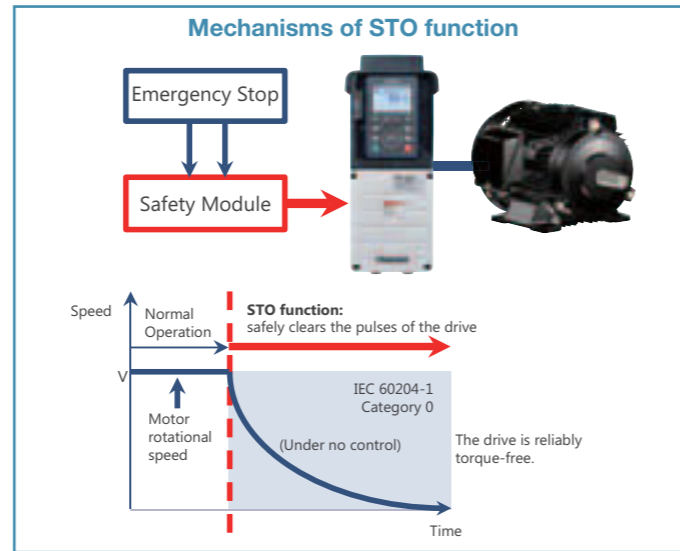

Harmonics reduction

The VF-AS3 is very friendly to a power supply system and peripheral equipment. The built-in dual DC reactor suppresses harmonic current and improves power factor.

VF-AS3 complies with IEC61000-3-12 and achieves total harmonic distortion (THDi) $\leq 48\%$ without external reactor. (480V Class only)

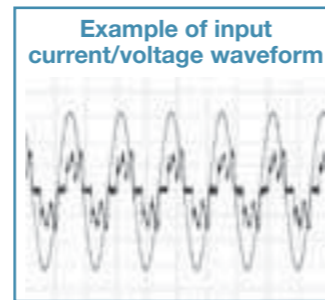

High-frequency noise reduction

The built-in EMC filter suppresses high frequency noise. The filter is ideal for sites such as commercial facilities, offices and factories where attentions must be paid to peripheral devices.

The VF-AS3 complies with EMC directive of IEC61800-3 Category C2/C3 without external filter. (480V Class only)

In addition, the VF-AS3 has built-in UL Type 1 terminal box integrated with EMC plate. Thus, the VF-AS3 complies with the UL Standard and CSA Standard without external devices.

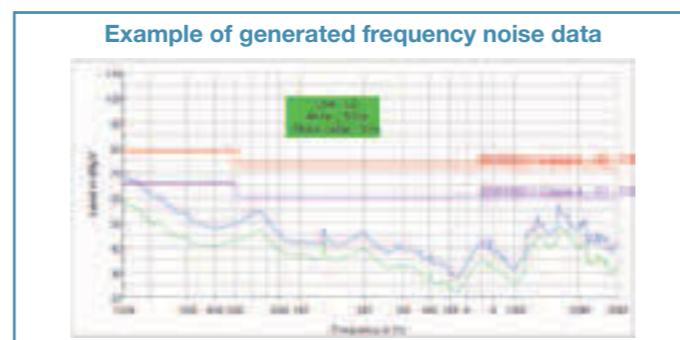
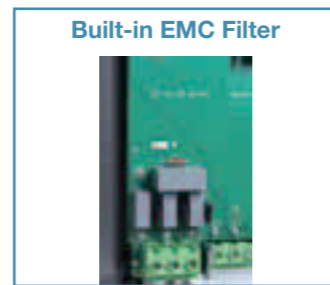

Detachable operation panel

The key pad is detachable and easy to attach an external control console. The optional panel is not required.

The protection level of the keypad is enclosed type with door mounting kit, which means dust-proof and wash-down capable.

The touch wheel has high sensitivity, which allows easy, smooth operation.



Wide, multi-language LCD screen (HMI)

The wide LCD panel (240 x 160 dots) displays multiple items at the same time, allowing easy setting of parameters.

If the VF-AS3 trips, the panel will turn red in back light color, and it's easy to recognize.

The panel can be displayed in multiple languages including German, Italian, Spanish, Portuguese, Chinese and Japanese as well as English.

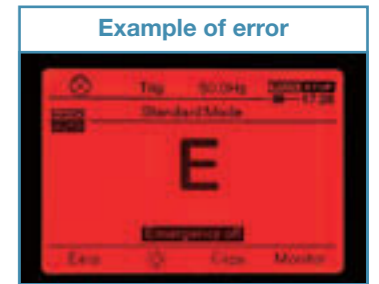

Detachable control terminal block

Detachable terminal block allows you to use the current control wiring when replacing the drive. It also makes maintenance much easier.



Various options

If more additional options are required, cassette-type options for network, extended terminal block, sensor feedback, and safety function can be added easily.

Communication network:

PROFINET^(*), PROFIBUS-DP^(*), DeviceNetTM^(**), EtherCAT[®]^(***), CANopen[®]^(****)

(*) PROFINET and PROFIBUS-DP are registered trademarks of PROFIBUS and PROFINET International .

(**) DeviceNetTM is a registered trademark of ODVA.

(***) EtherCAT[®] is a registered trademark of Beckhoff Automation .

(****) CANopen[®] is a registered trademark of CAN in Automation.

Inputs/Outputs:

Digital & Analog I/Os: 6-Digital Input, 2-Digital Output, 2-Analog Input
Relays: 3-Relay

Safety:

Safety option (SS1, SOS, SS2, SBC, SLS, SDI)

Sensor feedback:

Digital encoder: RS422 Line receiver
Resolver

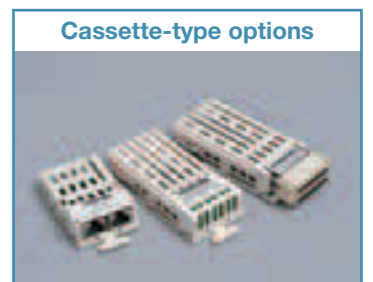

Basic functions

Each “setup item” that determines the control characteristics of the drive is called a “parameter”. For example, to change the acceleration time, you choose the acceleration time parameter (titled “ACC”).

Easy mode

To enter the Easy mode, press the F1 to F4 key of Easy marking on the panel. In this mode, you can set ten of the basic parameters.

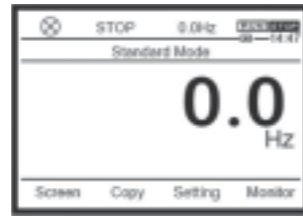

Title	Parameter name
CMOd	Run command select
FMOd	Frequency command select 1
ACC	Acceleration time 1
dEC	Deceleration time 1
UL	Upper limit frequency
LL	Lower limit frequency
tHrA	Motor overload protection current 1
FM	Terminal FM adjustment
PSEL	Parameter mode select

Setting mode

In this mode, you can set all parameters. For details of parameters, refer to the Instruction Manual.

Basic parameters

Title	Parameter name	Adjustment Range	Default setting
FC	Panel run frequency	LL-UL Hz	-
AUH	History function	-	-
AUF	Guidance function	0:- 1:Embedded Ethernet setting 2:Preset speed operation 3:Analog frequency command 4:Motor 1,2 switching 5:Motor parameter 6:PM motor parameter	0
AUA	Application easy setting	0:- 1:Initial easy setting 2:Conveyor 3:Material handling 4:Hoisting 5:Fan 6:Pump 7:Compressor	0
AUE	Eco-standby power setting	0:- +1:Embedded Ethernet OFF	0
AUL	Multi-rating select	0:- 1:- 2:ND rating(120%-60s)(0 after execution) 3:HD rating(150%-60s)(0 after execution) 4-8:-	0
AU1	Automatic Acc/Dec	0:Disabled 1:Automatic Acc/Dec 2:Automatic Acc only	0
AU2	Torque boost macro	0:Disabled 1:Automatic torque boost + offline auto-tuning 2:Vector control 1 + offline auto-tuning 3:Energy savings + offline auto-tuning	0
CMOd	Run command select	0:Terminal 1:Operation panel, Extension panel 2:Embedded Ethernet 3:RS485 communication(connector 1) 4:RS485 communication(connector 2) 5:Communication option	0
FMOd	Frequency command select 1	0:- 1:Terminal RR 2:Terminal RX 3:Terminal II 4:Terminal AI4(option) 5:Terminal AI5(option) 6-9:- 10:Touch wheel 1(power off or press OK to save) 11:Touch wheel 2(press OK to save) 12:St0 13-14:- 15:Terminal Up/Down frequency 16:Pulse train 17:High resolution pulse train(option) 18-19:- 20:Embedded Ethernet 21:RS485 communication(connector 1) 22:RS485 communication(connector 2) 23:Communication option	1
Pt	V/f Pattern	0:V/f constant 1:Variable torque 2:Automatic torque boost 3:Vector control 1 4:Energy savings 5:Dynamic energy savings(for fan and pump) 6:PM motor control 7:V/f 5-point setting 8:- 9:Vector control 2(speed/torque) 10:PG feedback control 11:PG feedback vector control(speed/torque) 12:-	0
vb	Manual torque boost 1	0.00-30.00 %	Depends on the capacity
vL	Base frequency 1	15.0-590 Hz	50.0/60.0
vLv	Base frequency voltage 1	240V class:50-330 V 480V class:50-660 V	Depends on the capacity
FH	Maximum frequency	30.0-590.0 Hz	Depends on the capacity
UL	Upper limit frequency	0.0-FH Hz	50.0/60.0
LL	Lower limit frequency	0.0-UL Hz	0.0
ACC	Acceleration time 1	0.0-6000(600.0) sec	Depends on the capacity
dEC	Deceleration time 1	0.0-6000(600.0) sec	Depends on the capacity
Sr0	Preset speed 0	LL-UL Hz	0.0
Sr1	Preset speed 1	LL-UL Hz	0.0
Sr2	Preset speed 2	LL-UL Hz	0.0
Sr3	Preset speed 3	LL-UL Hz	0.0
Sr4	Preset speed 4	LL-UL Hz	0.0
Sr5	Preset speed 5	LL-UL Hz	0.0
Sr6	Preset speed 6	LL-UL Hz	0.0
Sr7	Preset speed 7	LL-UL Hz	0.0
FPIId	PID 1 set value	F368-F367 Hz	0.0
Fr	Panel Fwd/Rev run select	0:Fwd run 1:Rev run 2:Fwd run(switchable F/R by panel) 3:Rev run(switchable F/R by panel)	0
tHrA	Motor overload protection current 1	Depends on the capacity	Depends on the capacity
OLM	Motor overload protection characteristic	0:Standard motor, OL2, No stall 1:Standard motor, OL2, Stall 2:Standard motor, No OL2 trip, No stall 3:Standard motor, No OL2 trip, Stall 4:Constant torque motor, OL2, No stall 5:Constant torque motor, OL2, Stall 6:Constant torque motor, No OL2 trip, No stall 7:Constant torque motor, No OL2 trip, Stall	0
FMSL	Terminal FM function	0-162	0
FM	Terminal FM adjustment	-	-
tyP	Default setting	0:- 1:50Hz setting 2:60Hz setting 3:Default setting 1 4:Clear past trips 5:Clear cumulative run time 6:Initialize type form 7:Store user settings 8:Rewrite user settings 9:Clear cumulative fan run time 10-11:- 12:Clear number of starting 13:Default setting 2(complete initialization) 14:Clear number of external equipment starting	0
SEt	Region setting check	0:Setup menu starting 1:Japan(read only) 2:Mainly North America(read only) 3:Mainly Asia(read only) 4:Mainly Europe(read only) 5:Mainly China(read only)	0
PSEL	Parameter mode select	0:Setting mode at power on 1:Easy mode at power on 2:Easy mode only	0
F1--	Extended parameters	Set parameters in more detail	-
F9--	Advanced parameters	Parameters with dedicated function are displayed	-
A---	Communication parameters	Parameters with communication function are displayed	-
C---	Changed parameters search & edit	-	-

For details on extended parameters, advanced parameters and communication parameters, please visit our web site (<http://www.inverter.co.jp/>)



Standard specifications

Standard specifications

<240 V class: HD rating>

Item	Specification															
Voltage class	240 V class															
Frame size	A1			A2	A3			A4			A5			A6		
Applicable motor (kW)	0.4	0.75	1.5	2.2	4.0	5.5	7.5	11	15	18.5	22	30	37	45	55	
Applicable motor (HP)	0.5	1	2	3	5	7.5	10	15	20	25	30	40	50	60	75	
Rating	Type	VFAS3-														
	Form	2004P	2007P	2015P	2022P	2037P	2055P	2075P	2110P	2150P	2185P	2220P	2300P	2370P	2450P	2550P
	Output capacity (kVA) ^{*1}	1.3	1.8	3.0	4.3	7.1	9.7	12.5	17.8	24.2	29.9	35.3	46.9	56.8	67.1	80.4
	Output current (A) ^{*2}	3.3	4.6	8.0	11.2	18.7	25.4	32.7	46.8	63.4	78.4	92.6	123	149	176	211
Output voltage	3-phase 200 V to 240 V (The maximum output voltage is equal to the input supply voltage)															
Overload current rating	150%-1 minute, 180%-2 s															
Electrical braking	Dynamic braking circuit	Built-in												Optional		
	Dynamic braking resistor	External braking resistor (Optional)														
Power supply	Voltage-frequency	3-phase 200 V to 240 V - 50/60 Hz														
	Allowable fluctuation	Voltage 170 V to 264 V ^{*3} , Frequency ± 5%														
Required power supply capacity (kVA) ^{*4}	0.7	1.4	2.4	3.7	5.9	7.7	10.5	15.7	20.6	24.9	30.7	40.5	49.6	61.0	73.3	
Degree of protection (IEC60529)	IP20												IP00			
Cooling method	Forced air-cooled															
Color	RAL7016 / RAL7035															
EMC filter (IEC61800-3)	Built-in filter	-														
	External filter ^{*5}	C2-50m (Carrier frequency: 4.0 kHz), C3-150m (4.0 kHz)						C2-50m (2.5 kHz), C3-150m (2.5 kHz)								
DC reactor	Built-in															
UL type1 kit	Built-in												Optional			
Harmonics THDI ≤ 48% (IEC61000-3-12)	Refer to the instruction manual for the current level															

<240 V class: ND rating>

Item	Specification															
Voltage class	240 V class															
Frame size	A1			A2	A3			A4			A5			A6		
Applicable motor (kW)	0.75	1.5	2.2	4.0	5.5	7.5	11	15	18.5	22	30	37	45	55	75	
Applicable motor (HP)	1	2	3	5	7.5	10	15	20	25	30	40	50	60	75	100	
Rating	Type	VFAS3-														
	Form	2004P	2007P	2015P	2022P	2037P	2055P	2075P	2110P	2150P	2185P	2220P	2300P	2370P	2450P	2550P
	Output capacity (kVA) ^{*1}	1.8	3.0	4.3	7.1	9.7	12.5	17.8	24.2	29.9	35.3	46.9	56.8	67.1	80.4	107
	Output current (A) ^{*2}	4.6	8.0	11.2	18.7	25.4	32.7	46.8	63.4	78.4	92.6	123	149	176	211	282
Output voltage	3-phase 200 V to 240 V (The maximum output voltage is equal to the input supply voltage)															
Overload current rating	120%-1 minute, 135%-2 s															
Electrical braking	Dynamic braking circuit	Built-in												Optional		
	Dynamic braking resistor	External braking resistor (Optional)														
Power supply	Voltage-frequency	3-phase 200 V to 240 V - 50/60 Hz														
	Allowable fluctuation	Voltage 170 V to 264 V ^{*3} , Frequency ± 5%														
Required power supply capacity (kVA) ^{*4}	1.2	2.3	3.3	5.9	7.8	10.3	15.0	20.6	24.9	29.4	40.5	49.3	59.6	73.3	98.1	
Degree of protection (IEC60529)	IP20												IP00			
Cooling method	Forced air-cooled															
Color	RAL7016 / RAL7035															
EMC filter (IEC61800-3)	Built-in filter	-														
	External filter ^{*5}	C2-50m (Carrier frequency: 4.0 kHz), C3-150m (4.0 kHz)						C2-50m (2.5 kHz), C3-150m (2.5 kHz)								
DC reactor	Built-in															
UL type1 kit	Built-in												Optional			
Harmonics THDI ≤ 48% (IEC61000-3-12)	Refer to the instruction manual for the current level															

*1: Capacity is calculated at 220 V for the 240 V class.

*2: Indicates rated output current setting when the PWM carrier frequency (parameter F300) is 4 kHz for frame size A1 to A5, 2.5 kHz for frame size A6.

*3: Lower limit of voltage for 240 V class is 180 V when the inverter is used continuously (load of 100%).

*4: Required power supply capacity varies with the value of the power supply side inverter impedance (including those of the input reactor and wires).

*5: Contact your Toshiba distributor for detail.

<480 V class: HD rating>

Item		Specification												
Voltage class		480 V class												
Frame size		A1			A2			A3			A4			
Applicable motor (kW)		0.4	0.75	1.5	2.2	4.0	5.5	7.5	11	15	18.5	22	30	37
Applicable motor (HP)		0.5	1	2	3	5	7.5	10	15	20	25	30	40	50
Rating	Type	VFAS3-												
	Form	4004PC	4007PC	4015PC	4022PC	4037PC	4055PC	4075PC	4110PC	4150PC	4185PC	4220PC	4300PC	4370PC
	Output capacity (kVA) ^{*1}	1.1	1.7	3.0	4.3	7.1	9.7	12.6	17.9	24.2	29.9	35.3	46.9	56.8
	Output current (A) ^{*2}	1.5	2.2	4.0	5.6	9.3	12.7	16.5	23.5	31.7	39.2	46.3	61.5	74.5
	Output voltage	3-phase 380 V to 480 V (The maximum output voltage is equal to the input supply voltage)												
	Overload current rating	150%-1 minute, 180%-2 s												
Electrical braking	Dynamic braking circuit	Built-in												
	Dynamic braking resistor	External braking resistor (Optional)												
Power supply	Voltage-frequency	3-phase 380 V to 480 V - 50/60 Hz												
	Allowable fluctuation	Voltage 323V to 528V ^{*3} , Frequency ± 5%												
	Required power supply capacity (kVA) ^{*4}	0.7	1.4	2.6	3.9	6.6	8.5	11.4	16.6	22.3	27.3	32.7	44.3	53.9
Degree of protection (IEC60529)		IP20												
Cooling method		Forced air-cooled												
Color		RAL7016 / RAL7035												
EMC filter (IEC61800-3)	Built-in filter	C2-50m (Carrier frequency: 4.0 kHz), C3-150m (4.0 kHz)												
	External filter ^{*5}	C2-150m (Carrier frequency: 4.0 kHz), C3-300m (4.0 kHz)												
DC reactor		Built-in												
UL type1 kit		Built-in												
Harmonics THDi ≤ 48% (IEC61000-3-12)		Refer to the instruction manual for the current level												

Item		Specification												
Voltage class		480 V class												
Frame size		A5			A6			A7			A8			
Applicable motor (kW)		45	55	75	90	110	132	160	200	220	280	315	375	450
Applicable motor (HP)		60	75	100	125	150	200	250	300	350	450	500	600	750
Rating	Type	VFAS3-												
	Form	4450PC	4550PC	4750PC	4900PC	4110KPC	4132KPC	4160KPC	4200KPC	4220KPC	4280KPC	4320KPC	4370KPC	4420KPC
	Output capacity (kVA) ^{*1}	67.1	80.8	111	132	161	191	239	295	325	419	469	550	616
	Output current (A) ^{*2}	88.0	106	145	173	211	250	314	387	427	550	616	720	800
	Output voltage	3-phase 380 V to 480 V (The maximum output voltage is equal to the input supply voltage)												
	Overload current rating	150%-1 minute, 180%-2 s						150%-1 minute, 165%-2 s						
Electrical braking	Dynamic braking circuit	Built-in			Optional			Built-in			Optional			
	Dynamic braking resistor	External braking resistor (Optional)												
Power supply	Voltage-frequency	3-phase 380 V to 480 V - 50/60 Hz						3-phase 380 to 440 V - 50 Hz, 3-phase 380 to 480 V - 60 Hz						
	Allowable fluctuation	Voltage 323 V to 528 V ^{*3} , Frequency ± 5%						Voltage 323 to 484 V - 50 Hz, 323 V to 528 V - 60 Hz ^{*3} , Frequency ± 5%						
	Required power supply capacity (kVA) ^{*4}	65.6	79.5	108	133	155	181	225	275	308	379	422	500	600
Degree of protection (IEC60529)		IP20						IP00						
Cooling method		Forced air-cooled												
Color		RAL7016 / RAL7035												
EMC filter (IEC61800-3)	Built-in filter	C3-150m (2.5 kHz)						C3-50m (2.5 kHz)						
	External filter ^{*5}	C2-150m (2.5 kHz), C3-300m (2.5 kHz)						C2-100m (2.5 kHz)						
DC reactor		Built-in						Attached						
UL type1 kit		Built-in			Optional				-					
Harmonics THDi ≤ 48% (IEC61000-3-12)		Refer to the instruction manual for the current level												

*1: Capacity is calculated at 440 V for the 480 V class.

*2: Indicates rated output current setting when the PWM carrier frequency (parameter F300) is 4 kHz for frame size A1 to A5, 2.5 kHz for frame size A6 to A8.

*3: Lower limit of voltage for 480 V class is 342 V when the inverter is used continuously (load of 100%).

*4: Required power supply capacity varies with the value of the power supply side inverter impedance (including those of the input reactor and wires).

*5: Contact your Toshiba distributor for detail.

<480 V class: ND rating>

Item		Specification												
Voltage class		480V class												
Frame size		A1			A2			A3			A4			
Applicable motor (kW)		0.75	1.5	2.2	4.0	5.5	7.5	11	15	18.5	22	30	37	45
Applicable motor (HP)		1	2	3	5	7.5	10	15	20	25	30	40	50	60
Rating	Type	VFAS3-												
	Form	4004PC	4007PC	4015PC	4022PC	4037PC	4055PC	4075PC	4110PC	4150PC	4185PC	4220PC	4300PC	4370PC
	Output capacity (kVA) ^{*1}	1.7	3.0	4.3	7.1	9.7	12.6	17.9	24.2	29.9	35.3	46.9	56.8	67.1
	Output current (A) ^{*2}	2.2	4.0	5.6	9.3	12.7	16.5	23.5	31.7	39.2	46.3	61.5	74.5	88.0
	Output voltage	3-phase 380 V to 480 V (The maximum output voltage is equal to the input supply voltage)												
	Overload current rating	120%-1 minute, 135%-2 s												
Electrical braking	Dynamic braking circuit	Built-in												
	Dynamic braking resistor	External braking resistor (Optional)												
Power supply	Voltage-frequency	3-phase 380 V to 480 V - 50/60 Hz												
	Allowable fluctuation	Voltage 323 V to 528 V ^{*3} , Frequency ± 5%												
	Required power supply capacity (kVA) ^{*4}	1.2	2.4	3.4	6.1	8.3	10.9	15.6	21.3	26.4	31.4	42.0	52.4	63.2
Degree of protection (IEC60529)		IP20												
Cooling method		Forced air-cooled												
Color		RAL7016 / RAL7035												
EMC filter (IEC61800-3)	Built-in filter	C2-50m (Carrier frequency: 4.0 kHz), C3-150m (4.0 kHz)												
	External filter ^{*5}	C2-150m (Carrier frequency: 4.0 kHz), C3-300m (4.0 kHz)												
DC reactor		Built-in												
UL type1 kit		Built-in												
Harmonics THDi ≤ 48% (IEC61000-3-12)		Refer to the instruction manual for the current level												

Item		Specification												
Voltage class		480 V class												
Frame size		A5			A6			A7			A8			
Applicable motor (kW)		55	75	90	110	132	160	220	250	280	315	375	450	500
Applicable motor (HP)		75	100	125	150	200	250	350	400	450	500	600	750	800
Rating	Type	VFAS3-												
	Form	4450PC	4550PC	4750PC	4900PC	4110KPC	4132KPC	4160KPC	4200KPC	4220KPC	4280KPC	4320KPC	4370KPC	4420KPC
	Output capacity (kVA) ^{*1}	80.8	111	132	161	191	230	325	367	419	469	550	616	720
	Output current (A) ^{*2}	106	145	173	211	250	302	427	481	550	616	720	800	900
	Output voltage	3-phase 380 V to 480 V (The maximum output voltage is equal to the input supply voltage)												
	Overload current rating	150%-1 minute, 180%-2 s						120%-1 minute, 135%-2 s						
Electrical braking	Dynamic braking circuit	Built-in			Optional			Built-in			Optional			
	Dynamic braking resistor	External braking resistor (Optional)												
Power supply	Voltage-frequency	3-phase 380 V to 480 V - 50/60 Hz						3-phase 380 to 440 V - 50 Hz, 3-phase 380 to 480 V - 60 Hz						
	Allowable fluctuation	Voltage 323 V to 528 V ^{*3} , Frequency ± 5%						Voltage 323 to 484 V - 50 Hz, 323 V to 528 V - 60 Hz ^{*3} , Frequency ± 5%						
	Required power supply capacity (kVA) ^{*4}	77.0	103	125	155	181	214	296	335	379	422	500	600	720
Degree of protection (IEC60529)		IP20						IP00						
Cooling method		Forced air-cooled												
Color		RAL7016 / RAL7035												
EMC filter (IEC61800-3)	Built-in filter	C3-150m (2.5 kHz)						C3-50m (2.5 kHz)						
	External filter ^{*5}	C2-150m (2.5 kHz), C3-300m (2.5 kHz)						C2-100m (2.5 kHz)						
DC reactor		Built-in						Attached						
UL type1 kit		Built-in			Optional				-					
Harmonics THDi ≤ 48% (IEC61000-3-12)		Refer to the instruction manual for the current level												

*1: Capacity is calculated at 440 V for the 480 V class.

*2: Indicates rated output current setting when the PWM carrier frequency (parameter F300) is 4 kHz for frame size A1 to A5, 2.5 kHz for frame size A6 to A8.

*3: Lower limit of voltage for 480 V class is 342 V when the inverter is used continuously (load of 100%).

*4: Required power supply capacity varies with the value of the power supply side inverter impedance (including those of the input reactor and wires).

*5: Contact your Toshiba distributor for detail.

Common Specifications

	Item	Specification
Control specifications	Control system	Sinusoidal PWM control
	Output voltage adjustment	Adjustable within the range of 50 - 330 V (240 V class) and 50 - 660 V (480 V class) by correcting the supply voltage
	Output frequency range	Setting between 0.01 - 590 Hz. Default max. frequency is set to 0.01 - 80 Hz. Maximum frequency adjustment (30 to 590Hz)
	Minimum setting steps of frequency	0.01 Hz: operation panel input (60 Hz base), 0.03 Hz: analog input (60 Hz base, 11 bit/0 - 10 Vdc)
	Frequency accuracy	Analog input: $\pm 0.2\%$ of the maximum output frequency (at $25\pm 10^\circ\text{C}$) Digital input: $\pm 0.01\% \pm 0.022$ Hz of the output frequency
	Voltage/frequency characteristics	V/f constant, variable torque, automatic torque boost, vector control, base frequency adjustment 1, 2, 3, and 4 (15 - 590Hz), V/f 5-point arbitrary setting, torque boost adjustment (0 - 30%), start frequency adjustment (0 - 10 Hz), stop frequency adjustment (0 - 30 Hz)
	Frequency setting signal	3 k Ω potentiometer (possible to connect to 1 - 10 k Ω -rated potentiometer) 0 - 10Vdc (input impedance Zin: 31.5 k Ω) -10 to +10 Vdc (Zin: 31.5 k Ω) 4 - 20 mAdc (Zin: 250 Ω)
	Terminal block frequency command	The characteristic can be set arbitrarily by two-point setting. Compliant with 7 types of input; analog input (RR, RX, II, AI4, AI5), and pulse input (S4, S5)
	Frequency jump	Three frequency can be set. Setting of jump frequency and width.
	Upper and lower limit frequencies	Upper limit frequency: 0 to max. frequency, lower limit frequency: 0 to upper limit frequency
	PWM carrier frequency	Frame size A1 to A4: adjustable between 1.0 - 16 kHz Frame size A5 to A8: adjustable between 2.5 - 8 kHz
	PID control	Adjustment of proportional gain, integral time, differential time and delay filter. Multi PID and external PID control.
	Torque control	Voltage command input specification: -10 - +10 Vdc
	Real Time Clock (RTC)	Current time (year, month, date, hour, minute), Timezone, Daylight saving time, 4 work days and 20 holidays can be set by parameters
Operation specifications	Acceleration/deceleration time	0.01 - 6000 sec. Selectable from among acceleration/deceleration. times 1, 2, 3 and 4. Automatic acceleration/deceleration function. S-pattern acceleration/deceleration 1 and 2 pattern adjustable.
	DC braking	Adjustment of braking start frequency (0 - [FH]Hz), braking (0 - 100%) and braking time (0 - 25.5 sec.). With emergency off braking function and motor shaft fix control function.
	Forward run/reverse run ^{*1}	Forward run with ON of the terminal [F], Reverse run with ON of the terminal [R] (Default setting). Coast stop with OFF of the terminal assigned Stad-by function. Emergency off by panel operation or terminal.
	Jog run ^{*1}	Jog run, if selected, allows jog operation from the operation panel Jog run operation by terminal block is possible by setting the parameters.
	Preset speed operation ^{*1}	By changing the combination of the terminals [S1], [S2], [S3], [S4], [S5] set frequency + 31-speed operation. Selectable between acceleration/deceleration time, torque limit and V/f by set frequency.
	Retry	Capable of restarting after a check of the power circuit elements in case the protective function is activated. Max. 10 times selectable arbitrarily. Waiting time adjustment (0 - 10 sec.)
	Soft stall	Automatic load reduction control at overloading. (Default: OFF)
	Cooling fan ON/OFF	The cooling fan will be stopped automatically to assure long life when unnecessary.
	Operation panel key operation ON/OFF control	Key lock selectable between STOP key only, MODE key only, etc. All key operations can be locked.
	Regenerative power ride-through control	Possible to keep the motor running using its regenerative energy in case of a momentary power failure. (Default: OFF)
	Auto-restart operation	Possible to restart the motor in coasting in accordance with its speed and direction. (Default: OFF)
	Simplified pattern operation	Possible to select each 8 patterns in 2 groups from 15-speed operation frequency. Max. 16 types of operation possible. Terminal operation/repeat operation possible.
	Commercial inverter switching	Possible to switch operation by commercial power supply or inverter
	Light-load high-speed operation	Increases the operating efficiency of the machine by increasing the rotational speed of the motor when it is operated under light load.
Droop function	When two or more inverters are used to operate a single load, this function prevents load from concentrating on one inverter due to unbalance.	
Override function	External input signal adjustment is possible to the operation frequency command value.	
Protective function	Protective function	Stall prevention, current limit, overcurrent, overvoltage, short circuit on the load side, ground fault on the load side ^{*4} , undervoltage, momentary power failure (15 ms or more), non-stop control at momentary power failure, overload protection, arm overload at starting, overcurrent on the load side at starting, overcurrent and overload at braking resistor, overheat, emergency off
	Electronic thermal characteristic	Switchable between standard motor/constant torque motor, adjustment of overload protection and stall prevention level.
	Reset	Reset by 1a contact closed (or 1b contact opened), or by operation panel. Or power supply OFF/ON. This function is also used to save and clear trip records.

(Continued overleaf)

(Continued)

	Item	Specification
Display function	Alarms	Stall prevention during run, overload limit, overload, undervoltage on power supply side, DC circuit undervoltage, setting error, in retry, upper limit, lower limit.
	Causes of failures	Overcurrent, overvoltage, overheat, short circuit on the load side, ground fault on the load side, inverter overload, arm overcurrent at starting, overcurrent on the load side at starting, Cooling fan fault, CPU fault, EEPROM fault, RAM fault, ROM fault, communication error, (braking resistor overcurrent/overload), (emergency off), (undervoltage), (undercurrent), (overtorque), (motor overload), (input phase failure), (output phase failure) The items in the parentheses are selectable.
	Monitoring function	Output frequency, frequency command, forward run/reverse run, output current, DC voltage, output voltage, compensated frequency, terminal input/output information, CPU version, past trip history, cumulative operation time, feedback frequency, torque, torque command, torque current, exiting current, PID feedback value, motor overload factor, inverter overload factor, PBR overload factor, PBR load factor, input power, output power, peak output current, peak DC voltage, RR input, II input, RX input, AI4 input, AI5 input, FM output, AM output, expansion I/O card option CPU version, integral input power, integral output power, communication option reception counter, communication option abnormal counter.
	Free unit display	Display of optional units other than output frequency (motor speed, line speed, etc), current ampere/% switch, voltage volt/% switch
	Automatic edit function	Searches automatically parameters that are different from the default setting parameters. Easy to find changed parameters.
	User default setting	User parameter settings can be saved as default settings. Allows to reset the parameters to the user-defined parameter settings.
	LED	Charge display
Input/output terminal logic function		Possible to select positive logic or negative logic with programmable input/output terminal function menu. 2 or 3 function can be assigned for some terminals. ^{*1} ^{*2} (Default setting: positive logic)
Sink/source switching		Possible to switch between minus common (CC) and plus common (P24) for digital input terminal. (Default setting: external power supply)
output signal	Failure detection signal	1c contact output (250Vac-2A (cos Φ =1), 30Vac-2A (Resistive), 250Vac=1A (cos Φ =0.4), 30Vdc=1A (L/R=7ms))
	Relay output	2x1a contact output (250Vac-2A (cos Φ =1), 30Vac-2A (Resistive), 250Vac=1A (cos Φ =0.4), 30Vdc=1A (L/R=7ms))
	Low speed/speed reach signal output ^{*2}	Digital output (24 Vdc, max. 50 mA)
	Output for frequency meter/Output for ammeter ^{*3}	Analog output for meter: 1 mA dc full-scale dc ammeter 0 - 20 mA (4 - 20 mA) output: DC ammeter (allowable load resistance: 500 Ω or less) 0 - 10 V output: DC voltmeter (allowable load resistance: 1 k Ω or more)
	Pulse train frequency output	Pulse train output (Up to 30 kpps, duty 50%)
Communication function		Ethernet standard 2-channel equipped (connector: RJ45) IEEE802.3/IEEE802.3u (Fast Ethernet) (10/100Mbps: Auto negotiation) RS485 standard 2-channel equipped (connector: RJ45) PROFINET, DeviceNet, PROFIBUS-DP, EtherCAT are optional.
Environments	Use environments	Indoor use. Altitude: 4800m or less for frame size A1 to A6, 3000m or less for frame size A7 and A8 (current reduction necessary when above 1000 m). Place not exposed to direct sunlight and free of corrosive and explosive gases.
	Ambient temperature	-15 to +60 $^\circ\text{C}$ ^{*5} Frame size A1 to A5: Current reduction, remove the top cover when above 50 $^\circ\text{C}$; Frame size A6: Current reduction when above 50 $^\circ\text{C}$ ^{*6} ; Frame size A7 and A8: Current reduction when above 50 $^\circ\text{C}$ (HD), above 45 $^\circ\text{C}$ (ND)
	Storage temperature	-25 to + 70 $^\circ\text{C}$ ^{*7}
	Relative humidity	5 to 95% (free from condensation)
	Vibration	Frame size A1 to A6: 5.9 m/s ² {0.6G} or less (10 - 55 Hz), Frame size A7, A8: 2.9 m/s ² {0.3G} or less (10 - 55 Hz)

^{*1}: 14 digital input terminals (of which 6 are options) are programmable digital input terminals, and they make it possible to arbitrarily select from 178 types of signals.

^{*2}: Programmable ON/OFF output terminals make it possible to arbitrarily select from 256 types of signals.

^{*3}: Programmable analog output terminals make it possible to arbitrarily select from 54 types of signals.

^{*4}: This function protects inverters from overcurrent due to output circuit ground fault.

^{*5}: Remove operation panel of the inverter when above 50 $^\circ\text{C}$.

^{*6}: VFAS3-4132KPC (ND): Current reduction when above 45 $^\circ\text{C}$.

^{*7}: Temperature applicable for a short term. e.g. during transportation

External dimensions

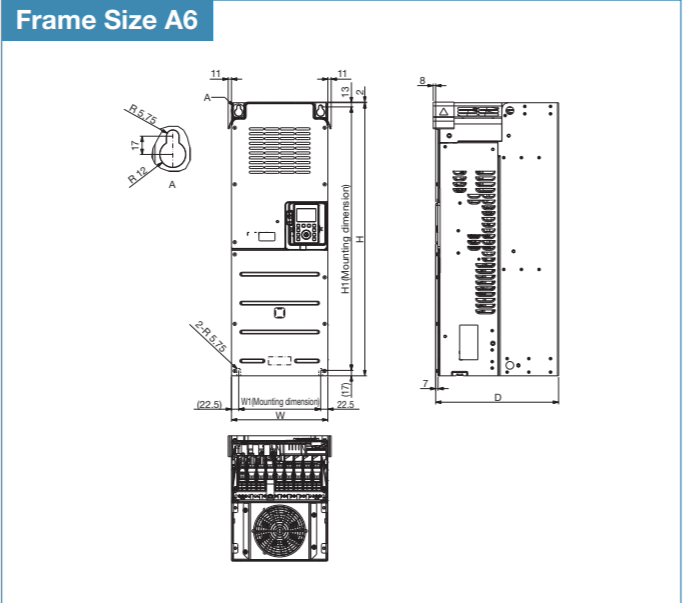
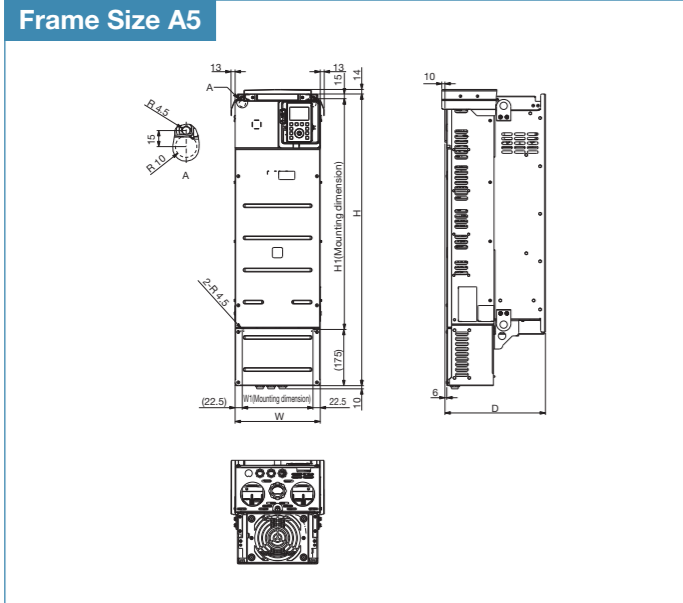
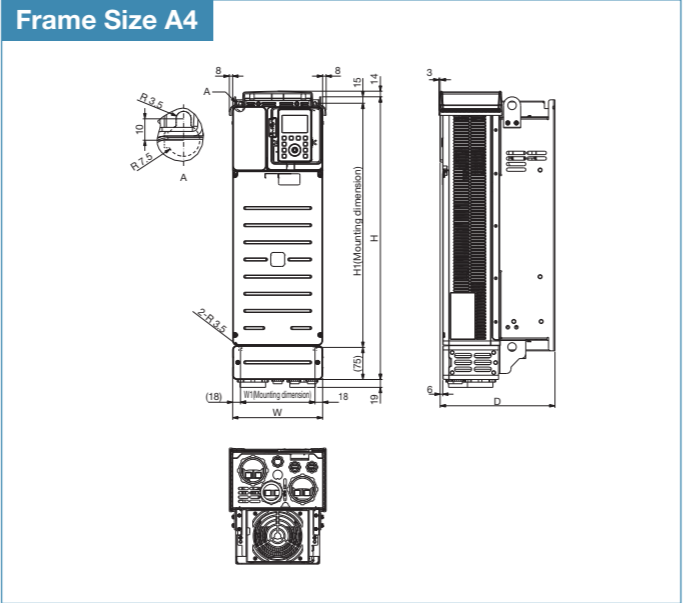
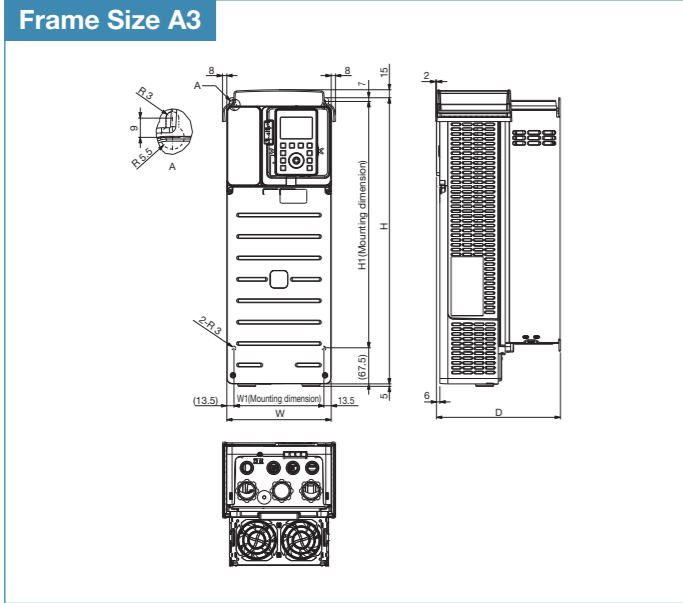
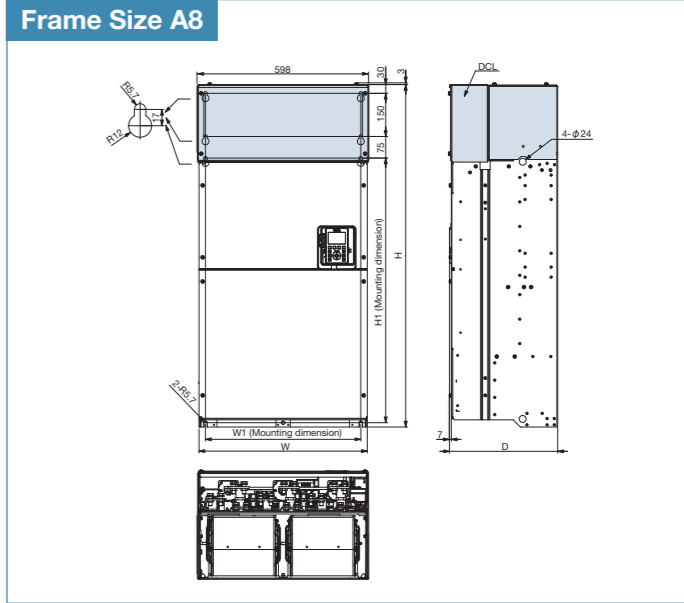
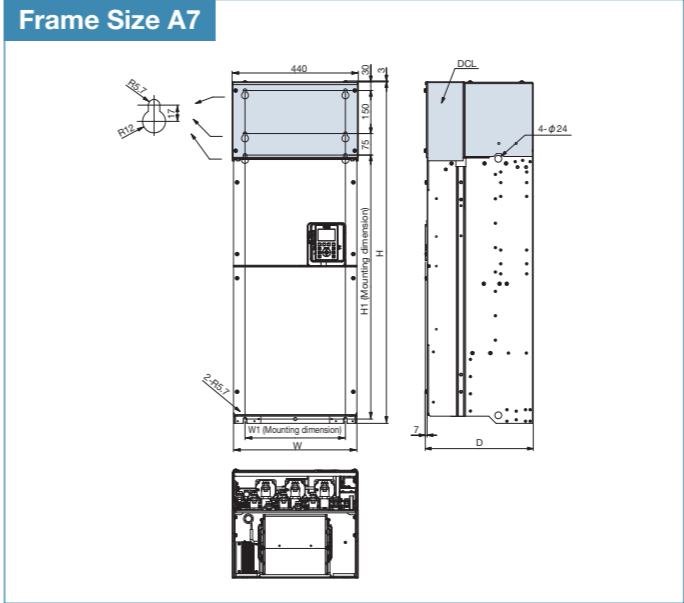
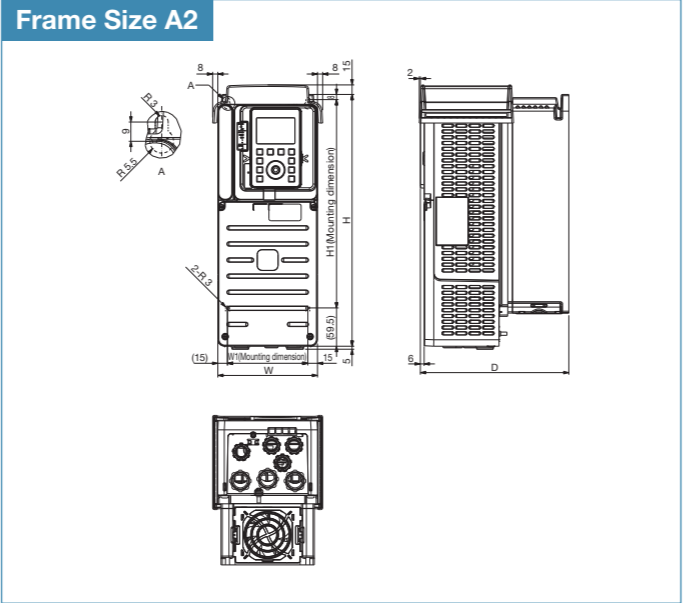
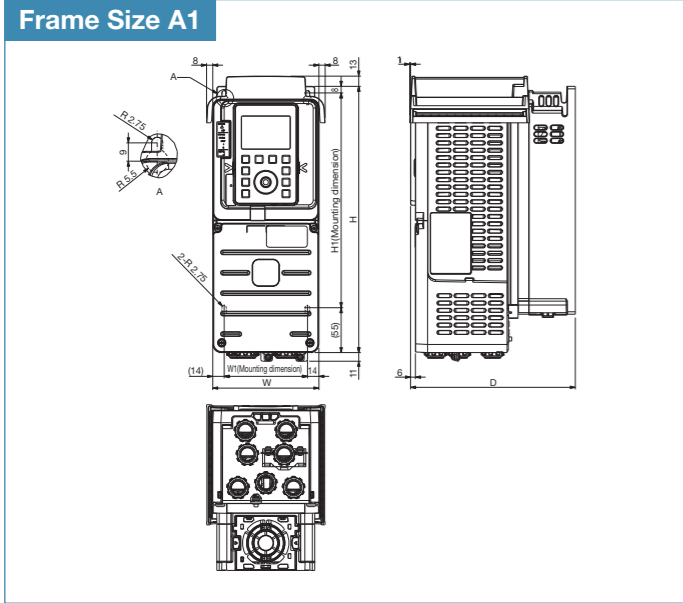

Input voltage Class	Applicable motor capacity (kW)	Drive type-form	Dimension (mm)					Frame Size	Approx. mass (kg)
			W	H	D	W1 *1	H1 *1		
3-phase 240 V	0.4	VFAS3-	130	326	202	102	263	A1	4.3
	0.75								4.3
	1.5								4.5
	2.2								4.6
	4.0								7.7
	5.5								13.8
	7.5								13.8
	11								27.3
	15								27.3
	18.5								27.3
	22								57.6
	30								57.6
	37								57.6
	45								82
3-phase 480 V	0.4	VFAS3-	130	326	202	102	263	A1	4.5
	0.75								4.5
	1.5								4.5
	2.2								4.6
	4.0								4.7
	5.5								7.7
	7.5								7.7
	11								13.6
	15								14.2
	18.5								14.3
	22								28
	30								28.2
	37								28.7
	45								57.5
55	59								
75	59.5								
90	82								
110	82								
132	82								
160	104 (166) ^{*2}								
200	134 (194) ^{*2}								
220	136 (204) ^{*2}								
280	136 (204) ^{*2}								

*1: W1 and H1 are the mounting dimensions of the drive.
 *2: Value in () includes attached DC reactor.

Standard connection diagrams

Standard connection diagram : Sink logic (common : CC)

Power supply
 240V class:
 VFAS3-2004P to VFAS3-2550P: 3-phase, 200 to 240V-50/60Hz
 480V class:
 VFAS3-4004PC to VFAS3-4132KPC: 3-phase, 380 to 480V-50/60Hz
 VFAS3-4160KPC to VFAS3-4280KPC: 3-phase, 380 to 440V-50Hz
 3-phase, 380 to 480V-60Hz

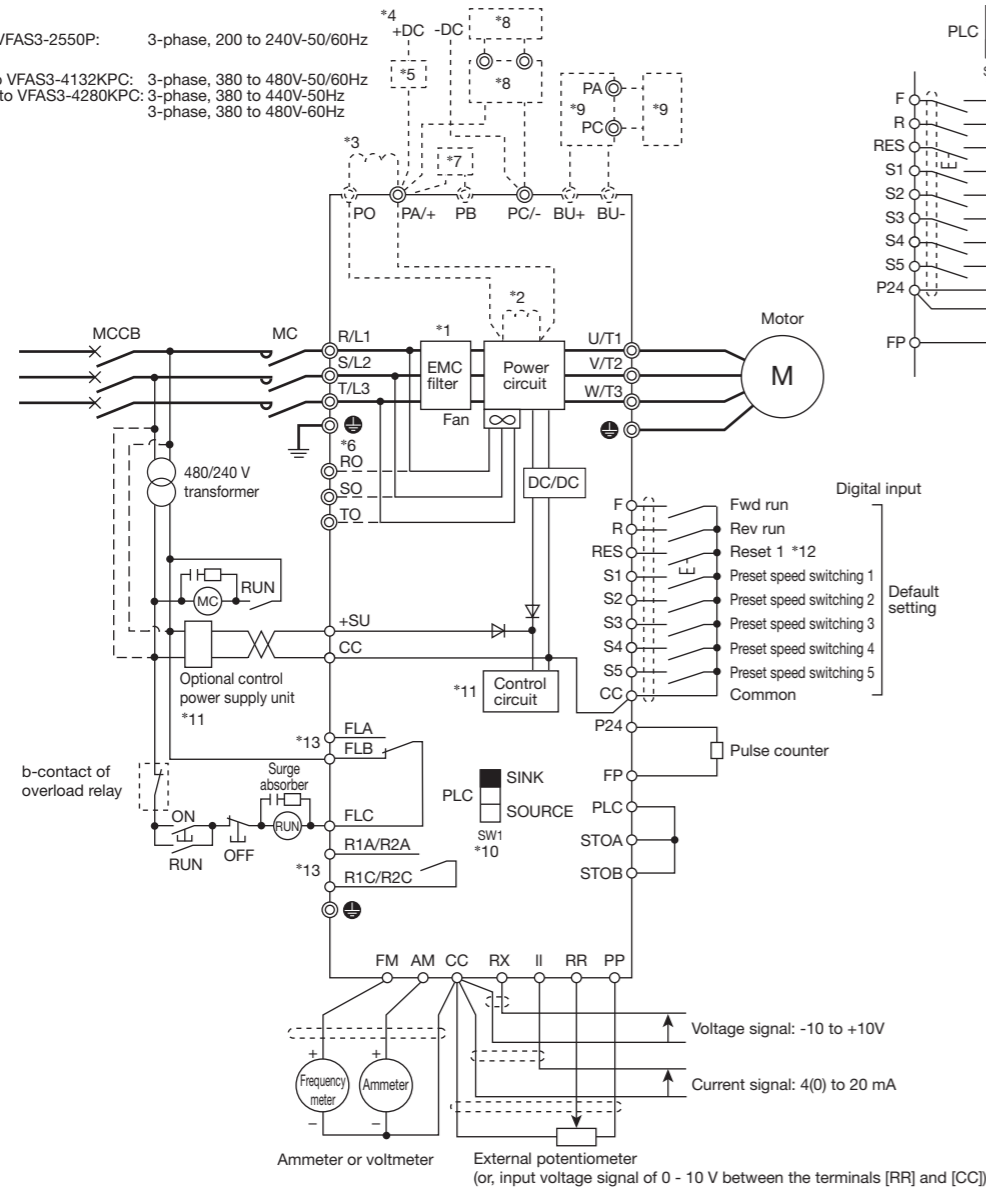

- *1: EMC filter is built in 480 V class.
- *2: The DC reactor is built in for models VFAS3-2004P to 2550P and VFAS3-4004PC to 4132KPC.
- *3: Be sure to mount the DC reactor for models VFAS3-4160KPC to 4280KPC. A circuit between the terminals [PA/+] and [PO] is not short circuited (at the time of shipping).
- *4: To input DC power, connect the inverter between the terminals [PA/+] and [PC/-]. It is not used in conjunction with the attached DC reactor for VFAS3-4160KPC to 4280KPC.
- *5: For models of VFAS3-2110P to 2550P and VFAS3-4220PC to 4280KPC, a rush current suppression circuit (optional) is required and please contact your Toshiba distributor for information.
- *6: When the inverter is used with a DC power supply, three-phase power input for cooling fan driving is required separately for models VFA3-4160KPC to 4280KPC.
- *7: External braking resistor (optional) for models VFAS3-2004P to 2370P and VFAS3-4004PC to 4750PC, VFAS3-4160KPC.
- *8: When a braking resistor (optional) is mounted, a braking unit (optional) is also required. for models VFAS3-2450P, 2550P and VFAS3-4900PC to 4132KPC.
- *9: When a braking resistor (optional) is mounted, a braking unit (optional) is also required. for models VFAS3-4200KPC to 4280KPC.
- *10: With the slide switch [SW1] of the control terminal block, the setting of sink logic, source logic and external power supply sink logic of the digital input terminals [F], [R], [RES], and [S1] - [S5] is switched.
- *11: To supply control power from an external power supply for backing up the control power supplied from the inverter, an optional control power supply unit (CPS002Z) is required. In this case, it is used in conjunction with the inverter internal power supply. Set [F647: Control power option failure detection] to back up the control power supply.
- *12: The reset signal is activated by ON → OFF trigger input.
- *13: Connect to power to comply with OVC2 (Over Voltage Category 2). Isolation transformer is necessary when connecting to power supply (OVC3).

Standard connection diagram : Source logic (common : P24)

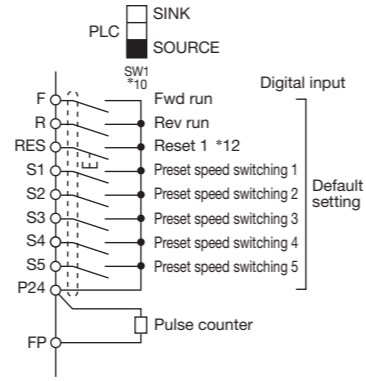

Terminal functions

Power terminal

Terminal symbol	Function	Applicable frame size
[PE]	Grounding terminal for inverter case. There are 3 terminals in cooling fin or mounting part of EMC plate.	All frame sizes
[R/L1] [S/L2] [T/L3]	Connected to an AC power supply. 240 V class: Three-phase 200 - 240 V-50/60 Hz 480 V class: VFAS3-4004PC to 4132KPC: Three-phase 380 - 480 V-50/60 Hz VFAS3-4160KPC to 4280KPC: Three-phase 380 - 440 V- 50 Hz Three-phase 380 - 480 V- 60 Hz	All frame sizes
[U/T1] [V/T2] [W/T3]	Connected to a three-phase motor.	All frame sizes
[PA/+] [PB]	Connected to a braking resistor. Change the parameters [F304: Dynamic braking, OLr trip], [F308: Braking resistance], and [F309: Braking resistor capacity] if necessary.	Frame size A1, A2, A3, A4, A5, and A7
[BU+] [BU-]	Inside the inverter. Connected to a braking unit (optional). Braking resistor (optional) is connected to a braking unit terminals [PA] and [PB].	Frame size A8
[PA/+] [PC/-]	A DC power can be input. For models of VFAS3-2110P to 2550P and VFAS3-4220PC to 4280KPC, a rush current suppression circuit (optional) is required. Connected to a braking unit (Optional) for frame size A6.	All frame sizes
[PA/+] [P0]	Be sure to connect the attached DC reactor.	Frame size A7 and A8
[RO] [SO] [TO]	Inverter's cooling power input terminals. When using a DC power supply, connect three-phase power wires.	Frame size A7 and A8

Control terminal

Terminal symbol	Input/output	Function	Electrical specifications
F	Input	Multifunction programmable digital input. In the default setting, forward run is performed with ON and deceleration stop with OFF.	Digital input. •24 Vdc-5 mA or less
R	Input	Multifunction programmable digital input. In the default setting, reverse run is performed with ON and deceleration stop with OFF.	Compliant with IEC61131-2 logic type 1
RES	Input	Multifunction programmable digital input. In the default setting, this inverter protective function is reset by ON → OFF. It has no effect when the inverter is in a normal condition.	•Sink logic: ON < 10 V, 16 V < OFF •Source logic: OFF < 5 V, 11 V < ON
S1	Input	Multifunction programmable digital input. In the default setting, preset speed operation is performed with ON	Sink logic and source logic can be switched with the slide switch [SW1]
S2	Input	Multifunction programmable digital input. In the default setting, preset speed operation is performed with ON	
S3	Input	Multifunction programmable digital input. In the default setting, preset speed operation is performed with ON	
S4	Input	Multifunction programmable digital input. In the default setting, preset speed operation is performed with ON. With [F146: Terminal S4 input select], digital input, pulse train input, and PG input can be switched.	Digital input. •24 Vdc-5 mA or less
S5	Input	Multifunction programmable digital input. In the default setting, preset speed operation is performed with ON. With [F147: Terminal S5 input select], digital input, pulse train input, and PG input can be switched.	Compliant with IEC61131-2 logic type 1 •Sink logic: ON < 10 V, 16 V < OFF •Source logic: OFF < 5 V, 11 V < ON Pulse train input •Up to 30 kpps (duty 50%)
CC	Common to input/output	An equipotential terminal of the control circuit. It is allocated in three positions.	-
PP	Output	10 Vdc power output for analog input setting.	10 Vdc (allowable load current: 10 mAdc)
FP	Output	Multifunction programmable digital/pulse train output. With [F669: Terminal FP switching], digital output and pulse train output can be switched.	Digital output •24 Vdc-50 mA Pulse train output •Up to 30 kpps (duty 50%)
RR	Input	Analog input with 0 - 10 Vdc. It can be switched to PTC input, etc. with [F108: Terminal RR input select].	0 - 10 Vdc (input impedance: 31.5 kΩ)
RX	Input	Analog input with -10 to +10 Vdc. With [F107: Terminal RX input voltage select], it can be switched to 0 - 10 Vdc.	-10 to +10 Vdc (input impedance: 31.5 kΩ)
II	Input	Analog current input with 0 - 20 mAdc. The current can be changed to 4 - 20 mA, etc. with setting of the parameter.	0 - 20 mAdc (input impedance: 250 Ω)
FM	Output	Multifunction programmable analog output. 0 - 10 Vdc output with default setting. With [F681: Terminal FM switching], meter option (0 - 1 mA), current (0 - 20 mA) output, and voltage (0 - 10 V) output can be switched.	0 - 10 Vdc (allowable load resistance: 1 kΩ or more)
AM	Output	Multifunction programmable analog output. 0 - 20 mAdc output with default setting. With [F686: Terminal AM switching], meter option (0 - 1 mA), current (0 - 20 mA) output, and voltage (0 - 10 V) output can be switched.	4 - 20 mAdc (0 - 20 mAdc) (allowable load resistance: 500 kΩ or less)
PLC	Output	When the slide switch [SW1] is set to the sink side or source side, it can be used as 24 Vdc power output.	24 Vdc-200 mA (200 mA in total with P24) Compliant with IEC61131-2
PLC	Input	When the slide switch [SW1] is set to the PLC side, it can be used as a common terminal for digital input terminal.	-
P24	Output	24 Vdc power output.	24 Vdc-200 mA (200 mA in total with PLC) Compliant with IEC61131-2
+SU	Input	DC power input to operate the control circuit. Connect a control power supply option or 24 Vdc power supply between [+SU] and [CC].	24 Vdc- current 1A or more
STOA	Input	At the time of shipping, the terminals [STOA]-[STOB]-[PLC] are shorted by the shorting bar. This is a terminal with STO function that complies with the safety standard IEC61800-5-2. For details, refer to Safety Function Manual. This terminal is not programmable digital input.	Refer to Safety Function Manual. Compliant with IEC61131-2 logic type 1 • Activate < 5 V, 11 V < Deactivate Not coast stop
STOB	Input		
FLA	Output	Multifunction programmable relay contact output. Operation of the protection function of the inverter is detected in the default setting. The contact across [FLA]-[FLC] is closed and [FLB]-[FLC] is opened during protection function operation.	Maximum contact capacity •250 Vac-2 A (cos φ=1) •30 Vdc-2 A (at resistive load)
FLB	Output		
FLC	Output		
R1A	Output	Multifunction programmable relay contact output. A low-speed signal is output in the default setting.	•250 Vac-1 A (cos φ=0.4) •30 Vdc-1A (L/R=7 ms)
R1C	Output		
R2A	Output	Multifunction programmable relay contact output. It is not assigned in the default setting. The function can be set with [F134: Terminal R2 function].	Minimum contact capacity •24 Vdc-5 mA Life •100000 times
R2C	Output		

For drive users

When studying how to use our drives

Notes

Leakage current

This drive uses high-speed switching devices for PWM control. When a relatively long cable is used for power supply to a drive, current may leak from the cable or the motor to the ground because of its capacitance, adversely affecting peripheral equipment. The intensity of such a leakage current depends on the PWM carrier frequency, the lengths of the input and output cables, etc., of the drive. To prevent current leakage, it is recommended to take the following measures.

[Effects of leakage current]

Leakage current which increases when a drive is used may pass through the following routes:

- Route (1) ... Leakage due to the capacitance between the ground and the noise filter
- Route (2) ... Leakage due to the capacitance between the ground and the drive
- Route (3) ... Leakage due to the capacitance between ground and the cable connecting the drive and the motor
- Route (4) ... Leakage due to the capacitance of the cable connecting the motor and a drive in another power distribution line
- Route (5) ... Leakage through the grounding line common to motors
- Route (6) ... Leakage to another line because of the capacitance of the ground

Leakage current which passes through the above routes may cause the following trouble.

- Malfunction of a earth leakage circuit breaker (ELCB) in the same or another power distribution line
- Malfunction of a ground-relay installed in the same or another power distribution line
- Noise produced at the output of an electronic device in another power distribution line
- Activation of an external thermal relay installed between the drive and the motor, at a current below the rate current

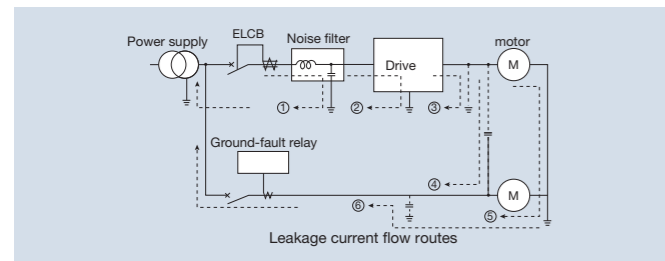

[Measures against effects of leakage current]

The measures against the effects of leakage current are as follows:

- 1) Measures to prevent the malfunction of ELCBs
 - (1) Decrease the PWM carrier frequency of the drive. Note)
 - (2) Use radio-frequency interference-proof ELCBs as ground-fault interrupters in not only the system into which the drive is incorporated but also other systems. When ELCBs are used, the PWM carrier frequency needs to be increased to operate the drive.
 - (3) When connecting multiple drives to a single ELCB, use an ELCB with a high current sensitivity or reduce the number of drives connected to the ELCB.
- 2) Measures against malfunction of ground-fault relay:
 - (1) Decrease the PWM carrier frequency of the drive. Note)
 - (2) Install ground-fault relays with a high-frequency protective function in both the same and other lines. When ELCBs are used, the PWM carrier frequency needs to be increased to operate the drive.
- 3) Measures against noise produced by other electric and electronic systems:
 - (1) Separate the grounding line of the drive from that of the affected electric and electronic systems.
 - (2) Decrease the PWM carrier frequency of the drive. Note)
- 4) Measures against malfunction of external thermal relays:
 - (1) Remove the external thermal relay and use the electronic thermal function of the drive instead of it. (Unapplicable to cases where a single drive is used to drive more than one motor. Refer to the instruction manual for measures to be taken when thermal relays cannot be removed.)
 - (2) Decrease the PWM carrier frequency of the drive. Note)
- 5) Measures by means of wiring and grounding
 - (1) Use a grounding wire as large as possible.
 - (2) Separate the drive's grounding wire from that of other systems or install the grounding wire of each system separately to the grounding point.
 - (3) Ground (shield) the power circuit wires with metallic conduits.
 - (4) Use the shortest possible wires to connect the drive to the motor.

- (5) If the drive has a high-attenuation EMC filter, turn off the grounding capacitor detachment switch to reduce the leakage current. Note that doing so leads to a reduction in the noise attenuating effect.
 - Note) In the case of this drive, the PWM carrier frequency can be decreased to 1.0kHz. However, that it should not be set to less than 2.0kHz during vector control. Decreasing the carrier frequency results in an increase in electromagnetic noise from the motor.

Ground fault

Before beginning operation, thoroughly check the wiring between the motor and the drive for incorrect wiring or short circuits. Do not ground the neutral point of any star-connected motor.

Radio interference

[Noise produced by drives]
Since this drive performs PWM control, it produces noise and sometimes affects nearby instrumental devices, electrical and electronic systems, etc. The effects of noise greatly vary with the noise resistance of each individual device, its wiring condition, the distance between it and the drive, etc.

[Measures against noises]
According to the route through which noise is transmitted, the noises produced by a drive are classified into transmission noise, induction noise and radiation noise.

[Examples of protective measures]

- Separate the power line from other lines, such as weak-current lines and signal lines, and install them apart from each other.
- Install a noise filter in each drive. It is effective for noise prevention to install noise filters in other devices and systems, as well.
- Shield cables and wires with grounded metallic conduits, and cover electronic systems with grounded metallic cases.
- Separate the power distribution line of the drive from that of other devices and systems.
- Install the input and output wires of the drive apart from each other.
- Use shielded twisted pair wires for wiring of the weak-current and signal circuits, and always ground one of each pair of wires.
- Ground the drive with grounding wires as large and short as possible, separately from other devices and systems.

On 480V models, noise can be greatly reduced as they have a built-in EMC noise filter on their input side.

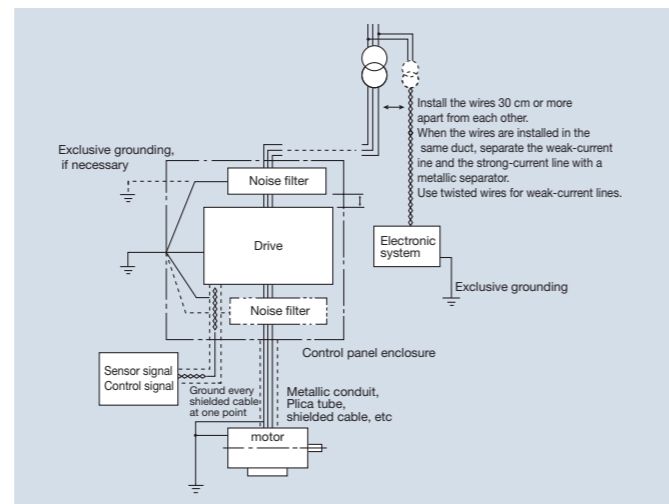

Power factor improvement capacitors

Do not install a power factor improvement capacitors on the input or output side of the drive. Installing a power factor improvement capacitor on the input or output side causes current containing harmonic components to flow into the capacitor, adversely affecting the capacitor itself or causing the drive to trip. To improve the power factor, install an input AC reactor on the primary side of the drive.

Installation of input AC reactors

These devices are used to improve the input power factor and suppress high harmonic currents and surges. Install an input AC reactor when using this drive under the following conditions:

- (1) When the power supply capacity is 500kVA or more, and when it is 10 times or more greater than the drive capacity.
- (2) When the drive is connected the same power distribution system as a thyristor-committed control equipment.
- (3) When the drive is connected to the same power distribution system as that of distorted wave-producing systems, such as arc furnaces and large-capacity drives.

When wiring the drive

Wiring precautions

Installing a molded-case circuit breaker [MCCB]

- (1) Install ELCB or MCCB with an electric leak detector on the drive's power supply input to protect the wiring.
- (2) Avoid turning the ELCB or MCCB on and off frequently to turn on/off the motor.
- (3) To turn on/off the motor frequently, ON/OFF the control terminals F (or R)-CC.

Installing a magnetic contactor [MC] [primary side]

- (1) To prevent an automatic restart after the power interruption or overload relay has tripped, or actuation of the protective circuit, install a magnetic contactor in the power supply.
- (2) The drive is provided with a failure detection relay (FL), so that, if its contacts are connected to the operation circuit of the magnetic contactor on the primary side, the magnetic contactor will be opened when the protective circuit of the drive is activated.
- (3) The drive can be used without a magnetic contactor. In this case, use an MCCB (equipped with a voltage tripping device) for opening the primary circuit when the drive protective circuit is activated.
- (4) Avoid turning the magnetic contactor on and off frequently to turn on/off the motor.
- (5) To turn on/off the motor frequently, ON/OFF the control terminals F (or R)-CC.

Installing a magnetic contactor [MC] [secondary side]

- (1) As a rule, if a magnetic contactor is installed between the drive and the motor, do not turn of ON/OFF while running. (If the secondary-side contactor is turned of ON/OFF while running, a large current may flow in the drive, causing drive damage and failure.)
- (2) A magnetic contactor may be installed to change the motor or change to the commercial power supply when the drive is stopped. Always use an interlock with the magnetic contactor in this situation so that the commercial power supply is not applied to the drive's output terminals.

External signal

- (1) Use a relay rated for low currents. Mount a surge absorber on the excitation coil of the relay.
- (2) When wiring the control circuit, use shielded wires or twisted pair cables.
- (3) Because all of the control terminals except FLA, FLB, FLC, R1A, R1B, R2A and R2B are connected to electronic circuits, insulate these terminals to prevent them from coming into contact with the power circuit.

Installing an overload relay

- (1) The drive has an electronic-thermal overload protective function. However, in the following cases, the thermal relay operation level must be adjusted or an overload relay matching the motor's characteristics must be installed between the drive and the motor.
 - (a) When operating a motor that is smaller than applied motor capacity.
 - (b) When driving several motors simultaneously.
- (2) When using the drive to control the operation of a constant-torque motor, change the protective characteristic of the electronic thermal relay according to the setting of constant torque motor.
- (3) In order to adequately protect a motor used for low-speed operation, we recommend the use of a motor equipped with an embedded thermal relay.

When changing the motor speed

Application to standard motors

Vibration

When a motor is operated with an industrial drive, it experiences more vibrations than when it is operated by the commercial power supply. The vibration can be reduced to a negligible level by securing the motor and machine to the base firmly. If the base is weak, however, the vibration may increase at a light load due to resonance with the mechanical system.

Reduction gear, belt, chain

Note that the lubrication capability of a reducer or a converter used as the interface of the motor and the load machine may be affected at low speeds. When operating at a frequencies over 60 Hz, power transmission mechanisms such as reduction gear, belts and chains, may cause problems such as production of noise, a reduction in strength, or shortening of service life.

Frequency

Before setting the maximum frequency to 60 Hz or more, confirm that this operating range is acceptable for the motor.

Application to special motors

Braking motor

When using a braking motor, if the braking circuit is directly connected to the drive's output terminals, the brake cannot be released because of the lowered starting voltage. Therefore, when using a braking motor, connect the braking circuit to the drive's power supply side, as shown on the below. Usually, braking motors produce larger noise in low speed ranges.

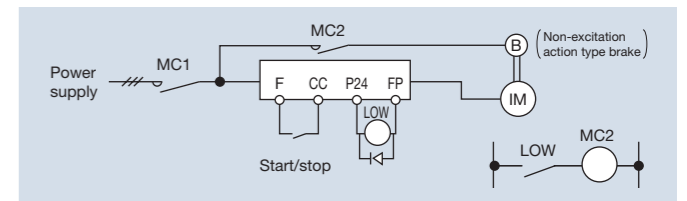

Gear motor

When using an industrial drive to drive a gear motor, inquire of the motor manufacturer about its continuous operation range, since low-speed operation of a gear motor may cause insufficient lubrication.

Toshiba Premium Gold Motor (High-efficiency power-saving motor)

Drive operation of Toshiba Premium Gold Motor is the best solution for saving energy. This is because these motors have improved efficiency, power factor, and noise/vibration reduction characteristics when compared to standard motors.

Pole-changing motor

Pole-changing motors can be driven by this drive. Before changing poles, however, be sure to let the motor come to a complete stop.

Hight-pole-count motors

Note that hight-pole count motors(8 or more poles), which may be used for fans,etc., have higher rated current than 4-pole motors. The current ratings of multipole motors are relatively high. So, when selecting a drive, you must pay special attention to its current rating so that the current rating of the motor is below that of the drive.

Single-phase motor

Because single-phase motors are equipped with a centrifugal switch and capacitors for starting, they cannot be driven by a drive.

For drive users

Selecting peripheral and wiring sizes devices for HD rating

Voltage class	Applicable motor (kW)	Drive type-form	Input current (A)	Molded-case circuit breaker (MCCB) or Earth leakage circuit breaker (ELCB) Note 1,2)	Magnetic contactor (MC) Note 1,3,4,5)	Wire size (mm) Note 6,7)					Drive Terminal Screw size Note 8)	
				Rated current (A)	Operational current (A) AC1	Power circuit		DC terminal	Braking resistor/Braking unit (optional) Note 9)	Grounding wire	Power terminal	Grounding Terminal
						Input terminal (R, S, T)	Output terminal (U, V, W)					
240V	0.4	VFAS3-2004P	1.7	3	20	1.5	1.5	2.5	1.5	2.5	M4	M5
	0.75	VFAS3-2007P	3.3	5	20	1.5	1.5	2.5	1.5	2.5		
	1.5	VFAS3-2015P	6.0	10	20	1.5	1.5	2.5	1.5	2.5		
	2.2	VFAS3-2022P	9.0	15	20	1.5	1.5	2.5	1.5	2.5		
	4.0	VFAS3-2037P	15.1	20	20	2.5	4	2.5	1.5	4	M4	M5
	5.5	VFAS3-2055P	20.1	30	32	4	6	4	1.5	6	M5	M5
	7.5	VFAS3-2075P	27.3	40	32	6	10	6	2.5	10		
	11	VFAS3-2110P	40.0	50	50	10	16	10	4	16	M8	M6 M8
	15	VFAS3-2150P	53.2	75	60	16	25	16	6	16		
	18.5	VFAS3-2185P	64.8	100	80	25	35	25	10	16		
	22	VFAS3-2220P	78.3	100	80	35	50	35	16	25		
	30	VFAS3-2300P	104.7	150	150	50	70	50	25	35	M12	M8 M12
	37	VFAS3-2370P	128.4	175	200	70	95	70	35	50		
	45	VFAS3-2450P	157.6	200	260	95	120	95	50	70	M10	M8 M10
	55	VFAS3-2550P	189.0	250	260	120	70x2	120	50	95		
	480V	0.4	VFAS3-4004PC	0.9	3	20	1.5	1.5	2.5	1.5	2.5	M4
0.75		VFAS3-4007PC	1.8	3	20	1.5	1.5	2.5	1.5	2.5		
1.5		VFAS3-4015PC	3.2	5	20	1.5	1.5	2.5	1.5	2.5		
2.2		VFAS3-4022PC	4.9	10	20	1.5	1.5	2.5	1.5	2.5		
4.0		VFAS3-4037PC	8.3	10	20	1.5	1.5	2.5	1.5	2.5		
5.5		VFAS3-4055PC	10.9	15	20	1.5	2.5	2.5	1.5	2.5		
7.5		VFAS3-4075PC	14.7	20	20	2.5	4	2.5	1.5	2.5	M4	M5
11		VFAS3-4110PC	21.4	30	32	4	6	4	1.5	4		
15		VFAS3-4150PC	28.9	40	32	6	10	6	2.5	10	M5	M5
18.5		VFAS3-4185PC	35.4	50	50	10	10	10	2.5	10		
22		VFAS3-4220PC	42.1	60	50	16	16	10	4	16	M8	M6 M8
30		VFAS3-4300PC	57.1	75	60	25	25	16	6	16		
37		VFAS3-4370PC	69.9	100	80	25	35	25	10	16		
45		VFAS3-4450PC	84.8	125	100	35	35	35	16	16		
55		VFAS3-4550PC	103.3	125	135	50	50	50	16	25	M12	M8 M12
75		VFAS3-4750PC	139.8	175	200	95	95	70	35	50		
90		VFAS3-4900PC	170.2	225	260	120	120	95	35	70	M10	M8 M10
110		VFAS3-4110KPC	203.5	250	260	70x2	70x2	70x2	50	95		
132		VFAS3-4132KPC	240.3	300	260	70x2	70x2	70x2	70	95		
160		VFAS3-4160KPC	290.0	350	350	120x2	95x2	150x2	95	120		
200	VFAS3-4200KPC	360.0	500	450	150x2	120x2	150x3	150	150	M12	M12	
220	VFAS3-4220KPC	395.0	500	450	150x3	120x2	150x3	150	150			
280	VFAS3-4280KPC	495.0	700	660	150x3	185x2	150x4	150	120x2			

- Note 1) Selections for use of the Toshiba 4-pole standard motor with power supply voltage of 200V/400V-50Hz.
- Note 2) Choose the MCCB or ELCB according to the power supply capacity.
- Note 3) When the motor is driven by commercial power supply switching, for example, use a magnetic contactor that is matched to AC-3 class motor rated current.
- Note 4) Attach surge absorber to the magnetic contactor and exciting coil of the relay.
- Note 5) In the case the magnetic contactor (MC) with 2a-type auxiliary contacts is used for the control circuit, raise the reliability of the contact by using 2a-type contacts in parallel connection.
- Note 6) The recommended wire size is that of the wire (e.g. 600V class, HIV cable) with continuous maximum permissible temperature of 75°C. Ambient temperature is 40°C or less and the wiring distance is 30m or less. The wire size comply with IEC60364-5-52 (Grounding wire: IEC60364-5-54). It does not comply with UL Standard.
- Note 7) For the control circuit, use shielded wires whose size (cross-section) is 0.75 mm² or more.
- Note 8) The screw size of the control terminals is M3.
- Note 9) Choose the wiring size according to the braking resistor value.

Selecting peripheral and wiring sizes devices for ND rating

Voltage class	Applicable motor (kW)	Drive type-form	Input current (A)	Molded-case circuit breaker (MCCB) or Earth leakage circuit breaker (ELCB) Note 1,2)	Magnetic contactor (MC) Note 1,3,4,5)	Wire size (mm) Note 6,7)					Drive Terminal Screw size Note 8)	
				Rated current (A)	Operational current (A) AC1	Power circuit		DC terminal	Braking resistor/Braking unit (optional) Note 9)	Grounding wire	Power terminal	Grounding Terminal
						Input terminal (R, S, T)	Output terminal (U, V, W)					
240V	0.75	VFAS3-2004P	3.0	5	20	1.5	1.5	2.5	1.5	2.5	M4	M5
	1.5	VFAS3-2007P	5.9	10	20	1.5	1.5	2.5	1.5	2.5		
	2.2	VFAS3-2015P	8.5	15	20	1.5	1.5	2.5	1.5	2.5		
	4.0	VFAS3-2022P	15.1	20	20	2.5	4	2.5	1.5	4		
	5.5	VFAS3-2037P	20.2	30	32	4	6	4	1.5	6	M4	M5
	7.5	VFAS3-2055P	27.1	40	32	6	10	6	2.5	10		
	11	VFAS3-2075P	39.3	50	50	10	16	10	4	16	M5	M5
	15	VFAS3-2110P	53.0	75	60	16	25	16	6	16		
	18.5	VFAS3-2150P	65.1	100	80	25	35	25	10	16		
	22	VFAS3-2185P	76.0	100	80	35	50	35	16	25		
	30	VFAS3-2220P	104.7	150	150	50	70	50	25	35	M8	M6 M8
	37	VFAS3-2300P	128.0	175	200	70	95	70	35	50		
	45	VFAS3-2370P	154.7	200	260	95	120	95	50	70	M12	M8 M12
	55	VFAS3-2450P	191.9	250	260	70x2	70x2	50x2	50	95		
	75	VFAS3-2550P	256.0	350	350	95x2	95x2	70x2	70	120	M10	M8 M10
	0.75	VFAS3-4004PC	1.6	3	20	1.5	1.5	2.5	1.5	2.5		
1.5	VFAS3-4007PC	3.1	5	20	1.5	1.5	2.5	1.5	2.5			
2.2	VFAS3-4015PC	4.5	10	20	1.5	1.5	2.5	1.5	2.5			
4.0	VFAS3-4022PC	8.0	10	20	1.5	1.5	2.5	1.5	2.5			
5.5	VFAS3-4037PC	10.8	15	20	1.5	2.5	2.5	1.5	2.5			
7.5	VFAS3-4055PC	14.4	20	20	2.5	4	2.5	1.5	2.5	M4	M5	
11	VFAS3-4075PC	20.8	30	32	4	6	4	1.5	4			
15	VFAS3-4110PC	28.3	40	32	6	10	6	2.5	10	M5	M5	
18.5	VFAS3-4150PC	34.9	50	50	10	10	10	2.5	10			
22	VFAS3-4185PC	41.4	50	50	16	16	10	4	16			
30	VFAS3-4220PC	55.9	75	60	10	25	16	6	16			
37	VFAS3-4300PC	69.0	100	80	25	35	25	10	16	M8	M6 M8	
45	VFAS3-4370PC	83.4	125	100	35	35	35	16	16			
55	VFAS3-4450PC	101.9	125	135	50	50	50	16	25	M12	M8 M12	
75	VFAS3-4550PC	138.0	175	200	70	95	70	35	50			
90	VFAS3-4750PC	165.1	200	260	95	120	95	35	70			
110	VFAS3-4900PC	203.5	250	260	50x2	50x2	70x2	35	95			
132	VFAS3-4110KPC	240.3	300	260	70x2	70x2	70x2	50	95	M10	M8 M10	
160	VFAS3-4132KPC	284.2	350	350	95x2	95x2	95x2	70	120			
220	VFAS3-4160KPC	395.0	500	450	150x2	150x2	150x2	95	150	M10/M12	M12	
250	VFAS3-4200KPC	444.0	500	450	150x2	150x2	150x2	150	150			
280	VFAS3-4220KPC	495.0	700	660	150x3	120x3	150x3	150	120x2	M12	M12	
315	VFAS3-4280KPC	555.0	1000	660	150x3	150x3	150x3	150	120x2			

- Note 1) Selections for use of the Toshiba 4-pole standard motor with power supply voltage of 200V/400V-50Hz.
- Note 2) Choose the MCCB or ELCB according to the power supply capacity. For comply with UL and CSA standard, use the fuse certified by UL and CSA.
- Note 3) When the motor is driven by commercial power supply switching, for example, use a magnetic contactor that is matched to AC-3 class motor rated current.
- Note 4) Attach surge absorber to the magnetic contactor and exciting coil of the relay.
- Note 5) In the case the magnetic contactor (MC) with 2a-type auxiliary contacts is used for the control circuit, raise the reliability of the contact by using 2a-type contacts in parallel connection.
- Note 6) The recommended wire size is that of the wire (e.g. 600V class, HIV cable) with continuous maximum permissible temperature of 75°C. Ambient temperature is 40°C or less and the wiring distance is 30m or less. The wire size comply with IEC60364-5-52 (Grounding wire: IEC60364-5-54). It does not comply with UL Standard.
- Note 7) For the control circuit, use shielded wires whose size (cross-section) is 0.75 mm² or more.
- Note 8) The screw size of the control terminals is M3.
- Note 9) Choose the wiring size according to the braking resistor value.

Selecting the Capacity (model) of the Drive

selection

Capacity

Refer to the applicable motor capacities listed in the standard specifications. When driving a high-pole motor, special motor, or multiple motors in parallel, select such a drive that the sum of the motor rated current multiplied by 1.05 to 1.1 is less than the drive's rated output current value.

Acceleration/deceleration times

The actual acceleration and deceleration times of a motor driven by a drive are determined by the torque and moment of inertia of the load, and can be calculated by the following equations. The acceleration and deceleration times of a drive can be set individually. In any case, however, they should be set longer than their respective values determined by the following equations.

Acceleration time	$t_a = \frac{(JM+JL) \times \Delta N}{9.56 \times (TM-TL)}$ (sec.)
Deceleration time	$t_d = \frac{(JM+JL) \times \Delta N}{9.56 \times (TB+TL)}$ (sec.)
Conditions	<p>JM : Moment of inertia of motor (kg.m²) JL : Moment of inertia of load (kg.m²) (converted into value on motor shaft) ΔN : Difference in rotating speed between before and after acc. or dec. (min.⁻¹) TL : Load torque (N.m) TM : Motor rated torque x 1.1 (N.m) ... V/f control TB : Motor rated torque x 0.2 (N.m) ... Vector operation control TL : Motor rated torque x 0.2 (N.m) (When a braking resistor or a braking resistor unit is used.) Motor rated torque x 0.8-1.0 (N.m)</p>

Allowable torque characteristics

When a standard motor is combined with a drive to perform variable speed operation, the motor temperature rises slightly higher than it normally does during commercial power supply operation. This is because the drive output voltage has a sinusoidal (approximate) PWM waveform. In addition, the cooling becomes less effective at low speed, so the torque must be reduced according to the frequency.

When constant-torque operation must be performed at low speeds, use a constant-torque motor designed specifically for use with drives.

Starting characteristics

When a motor is driven by a drive, its operation is restricted by the drive's overload current rating, so the starting characteristic is different from those obtained from commercial power supply operation. Although the starting torque is smaller with a drive than with the commercial power supply, a high starting torque can be produced at low speeds by adjusting the V/f pattern torque boost amount or by employing vector control. When a larger starting torque is necessary, select a drive with a larger capacity and examine the possibility of increasing the motor capacity.

Peripheral devices

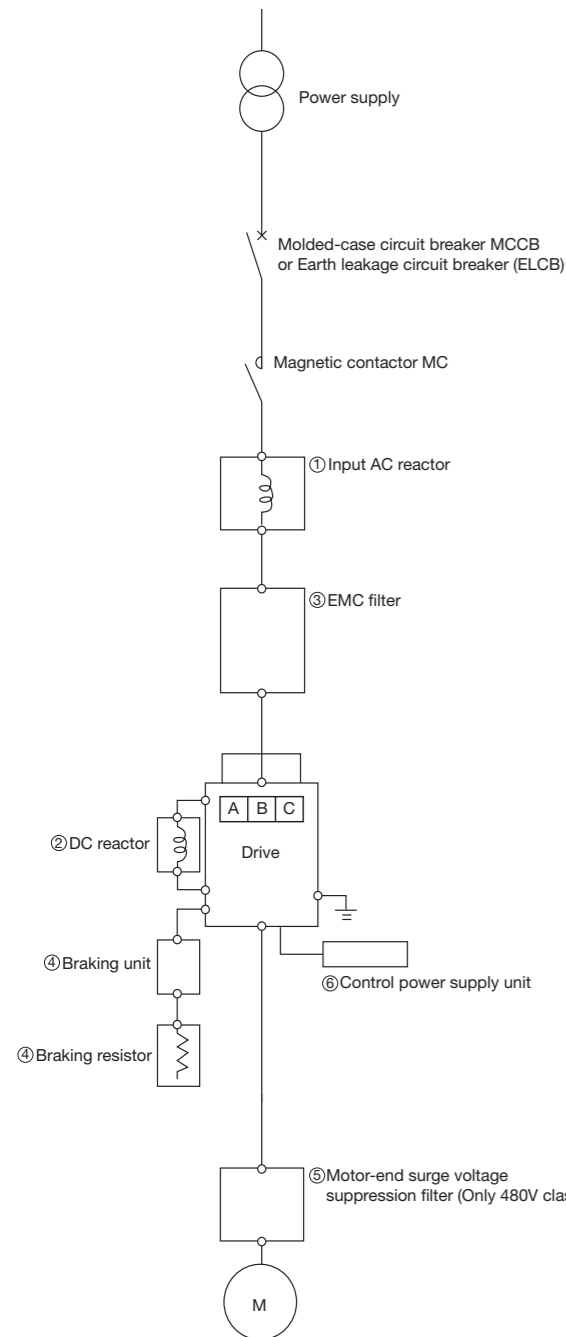

Insert type options

Slot	Name	Function/Purpose, etc	Refer to
A,B,C	I/O extension 1	This option is convenient for adding on I/O terminals.(Type:ETB013Z)	
A,B,C	I/O extension 2	This option is convenient for adding on I/O terminals.(Type:ETB014Z)	
B	Digital encoder	Closed loop operation is possible by combining with a motor equipped with a sensor.(Type:VEC008Z)	
B	Resolver	Closed loop operation is possible by combining with a motor equipped with a sensor.(Type:VEC010Z)	
C	Safety option	This option enables adding on more safety functions. (Type:SFT001Z)	
A	PROFINET	This option enables PROFINET connectivity with a host controller or other PLC. (Type:PNE001Z)	
A	PROFIBUS-DP	This option enables PROFIBUS-DP connectivity with a host controller or other PLC. (Type:PDP003Z)	
A	DeviceNet	This option enables DeviceNet connectivity with a host controller or other PLC. (Type:DEV003Z)	
A	EtherCAT	This option enables EtherCAT connectivity with a host controller or other PLC. (Type:IPE003Z)	
A	CANopen	This option enables CANopen connectivity with a host controller or other PLC. (Type:CAN001Z,CAN002Z,CAN003Z)	

External options

No.	Name	Function/Purpose, etc	Refer to														
①	Input AC reactor	Input AC reactor is used for improving input power factor on the drive power side (primary side), reducing harmonics or restriction of surge voltage. It is also installed when the power supply capacity is 500 kVA or more and is 10 times or more of the drive capacity, and when devices that cause distorted waves (a device with thyristor, etc.) and a large capacity drive is connected on the same power distribution line. Install an input AC reactor between the power supply and the drive (primary side). <table border="1"> <thead> <tr> <th>Type</th> <th>Effect</th> </tr> <tr> <td></td> <td>Power factor improvement</td> <td>Harmonics reduction</td> <td>Surge Voltage restriction</td> </tr> </thead> <tbody> <tr> <td>Input AC reactor</td> <td>Enabled</td> <td>Enabled</td> <td>Enabled</td> </tr> <tr> <td>DC reactor</td> <td>Enabled (large)</td> <td>Enabled (large)</td> <td>Disabled</td> </tr> </tbody> </table>	Type	Effect		Power factor improvement	Harmonics reduction	Surge Voltage restriction	Input AC reactor	Enabled	Enabled	Enabled	DC reactor	Enabled (large)	Enabled (large)	Disabled	
Type	Effect																
	Power factor improvement	Harmonics reduction	Surge Voltage restriction														
Input AC reactor	Enabled	Enabled	Enabled														
DC reactor	Enabled (large)	Enabled (large)	Disabled														
②	DC reactor	A DC reactor is a reactor to connect with the DC terminal, and used for improving input power factor and reducing harmonics. It has better power factor improvement effect than an input AC reactor. When a facility applying the drive requires high reliability, it is recommended to use with an input AC reactor that has surge voltage restriction effect. However, the frame size A1 to A6 of the drive has a built-in DC reactor as standard, and the frame size A7 and A8 attached with a DC reactor, no option is available.															
③	EMC filter	When installing an EMC filter and wire properly, it can comply with EMC Directive. 480 V model of the drive has the built-in EMC filter as standard; however, if an EMC filter is added externally, noise reduction becomes more effective. Please contact your Toshiba distributor for details.															
④	Braking resistor Braking unit	It is a resistor to consume regenerative energy from a motor. When making frequent rapid deceleration and stop, it is used to shorten deceleration time with load in large inertia. A braking unit is necessary in addition to a braking resistor for the frame size A6 and A8.															
⑤	Motor-end surge voltage suppression filter (Only 480V class)	When operating a 480 V class general purpose motor with a voltage type PWM control drive that uses high speed switching element (IGBT, etc.), surge voltage exceeding the insulation level of motor winding is generated depending on power supply voltage, motor wire length and its laying method, and type. When the condition is repeatedly applied for a long time, it may cause deterioration of insulation on the motor. Such measures as installation of an AC reactor, surge voltage suppression filter, sinusoidal filter on the drive output side (secondary side), and use of a high insulation strength motor are necessary.															
⑥	Control power supply unit	Control power need not be input separately as it is supplied internally on the drive from the power circuit power supply. Use this option when backing up only by the control power supply when the power circuit is shut off. This is +24 VDC output common to both 240 and 480 V models. (Type : CPS002Z)															
⑦	USB communications conversion unit	It enables to set and manage parameters on a personal computer. Connect between the RS485 communication connector 2 of the drive and a personal computer. Use the specific cable for the drive side, and a commercial USB cable (USB 1.1/2.0 compatible A-B connection type) for a personal computer side. Software PCGM002Z for parameter management is required. (Type: USB001Z, Specific cable Type: CAB0011 (1 m), CAB0013 (3 m), CAB0015 (5 m))															
⑧	Door mounting kit for Operation panel	The operation panel can be mounted on a cabinet surface by means of an door mounting kit. (Type:SBP010Z, Specific cable Type:CAB0071 (1 m), CAB0073 (3 m), CAB0075 (5 m), CAB00710 (10 m))															
⑨	LED extension panel	It is an extension panel for LED display. A specific cable is used to connect between the drive and LED panel. (Type: RKP002Z, Specific cable Type: CAB0011 (1 m), CAB0013 (3 m), CAB0015 (5 m); Type: RKP007Z, Specific cable Type: CAB0071 (1 m), CAB0073 (3 m), CAB0075 (5 m))															
⑩	Flange mounting kit	This allows heat generated inside panels to be reduced.															
⑪	Operation panel	Has a built-in frequency type, frequency setter and RUN-STOP (forward run, reverse run) switch. (Type: CBVR-7B1)															

Note1) Ethernet cable: LAN cable comply with ANSI/TIA/EIA-568-B.2 (CAT5E or successor)
 Note2) A lithium battery for internal real time clock of the operation panel (equipped as standard at the time of shipping): CR2032EC(Toshiba)

Harmonic current and influence to power supply

Harmonics are defined as sinusoidal waves that is multiple frequency of commercial power supply (base frequency: 50Hz or 60Hz). Commercial power supply including harmonics has a distorted waveform. Some electrical and electronic devices produce distorted waves in their rectifying and smoothing circuits on the input side. Harmonics produced by a device influence other electrical equipment and facilities in some cases (for example, overheating of phase advancing capacitors and reactors).

Measures for suppressing higher harmonics

No.	Measures	Description
1	Connecting a reactor	The leakage of a harmonic current from a drive can be restricted by connecting an input AC reactor (ACL) on the input side of the drive or a DC reactor (DCL) to the DC section of the drive.
2	Connecting a higher harmonic suppressing unit	A PWM converter that shapes the waveform of an input current into a substantially sinusoidal waveform. The leakage of a harmonic current from a power supply can be restricted by connecting a harmonic suppressing unit.
3	Connecting a higher harmonic suppressing phase advancing capacitor	A harmonic current can be absorbed by the use of a phase advancing capacitor unit composed of a phase advancing capacitor and a DC reactor.
4	Multi-pulse operation of transformation	For delta-delta connection and delta-Y connection transformers, the effect of 12 pulses can be obtained by distributing the load evenly, and thus currents containing fifth-order and seventh-order harmonics can be suppressed.
5	Other measures	Harmonic currents can also be suppressed by the use of passive (AC) and active filters.

Insert type options

This drive is equipped with two option slots (A, B) as standard. The option adaptor (option) can be mounted.

Table of optional devices

Name	Specification	Type-form	Slot availability
I/O extension 1	6x digital input 2x digital output 2x analog input	ETB013Z	A, B, C
I/O extension 2	3x 1a relay	ETB014Z	A, B, C
Digital encoder	RS422 Line receiver	VEC008Z	B
Resolver	Resolver	VEC010Z	B
Safety option	SS1, SS2, SOS, SBC, SMS, SLS, SDI, SSM	SFT001Z	C
PROFINET	PROFINET interface	PNE001Z	A
EtherCAT	EtherCAT interface	IPE003Z	A
PROFIBUS-DP	PROFIBUS-DP interface	PDP003Z	A
DeveceNet	DeviceNet interface	DEV003Z	A
CANopen	CANopen interface : RJ45 : D-sub : Open style	CAN001Z CAN002Z CAN003Z	A

Function of I/O extension

Type-form	ETB013Z	ETB014Z
Multifunction programmable contact input	Multifunction programmable contact input : 6 points Logic type selected by DICC wiring. Sink logic:ON<10V, 16V<OFF Source logic:OFF<5V, 11V<ON	Disable
Multifunction programmable open collector output	Multifunction programmable open collector output : 2 points Logic Type selected by DQCC wiring Max. switching voltage<= 30V Max. switching current<= 100mA Voltage drop at 100mA load <= 3V	Disable
Multifunction programmable relay contact output	Disable	Multifunction programmable relay contact output: 3 relay(1a) 250 Vac-2A(cosφ=1), 30 Vdc-2A (at resistive load) 250 Vac-1A(cosφ=0.4), 30 Vdc-1A (L/R=7 ms)
Analog input	Differential analog input: 2 points Voltage input: -10Vdc to +10Vdc Impedance: 20kohm Current input: 0 to 20mA Impedance: 250ohm	Disable

Function sensor feedback

Type-form	VEC008Z	VEC010Z
Sensor type	Incremental rotary encoder	Resolver
Specification	Signal interface: differential line driver (TIA/EIA RS422) Pulse frequency: 300kHz or less (Duty: 50% ±10%) Maximum load of power supply for encoder: 24V 100mA, 12V 100mA, 5V 250mA	Signal interface:Ref+, Cos-, Sin+, Cos+, Sin-, Ref- Excitation Carrier:3 to 12kHz Pole pairs number = 1 Transformation ratio = 0.3/0.5/0.75/1.0 Reference (Excitation voltage): 7Vrms
Connector	D subminiature connector (DE-15 / HD15)	D subminiature connector (DE-9)

How to install

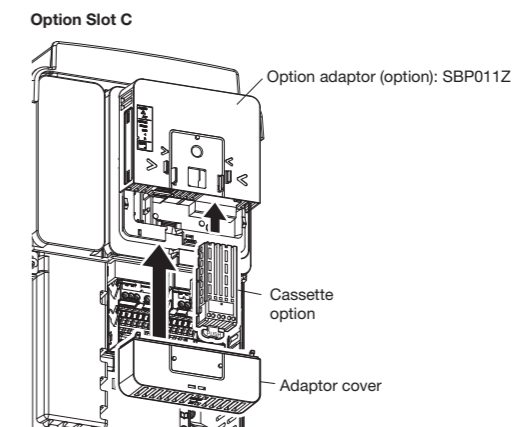
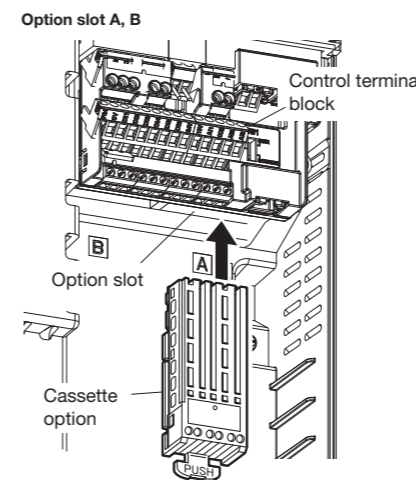

Note) The depth of the drive increases about 44mm when the option is mounted.

External options for HD rating

Voltage class	Applicable motor (kW)	Drive type-form	Input AC reactor (ACL)	DC reactor (DCL)	Braking unit	Braking resistor	Motor-end surge voltage suppression filter	Flange mounting kit	
240V	0.4	VFAS3-2004P	PFL-2005S	Built-in	Built-in	PBR-2007	-	FOT018Z	
	0.75	VFAS3-2007P	PFL-2005S			PBR-2007		FOT018Z	
	1.5	VFAS3-2015P	PFL-2011S			PBR-2022		FOT018Z	
	2.2	VFAS3-2022P	PFL-2011S			PBR-2022		FOT018Z	
	4.0	VFAS3-2037P	PFL-2018S			PBR-2037		FOT019Z	
	5.5	VFAS3-2055P	PFL-2025S			PBR7-004W015		FOT020Z	
	7.5	VFAS3-2075P	PFL-2050S			PBR7-004W015		FOT020Z	
	11	VFAS3-2110P	PFL-2050S			PBR7-008W7R5		FOT021Z	
	15	VFAS3-2150P	PFL-2100S			PBR7-008W7R5		FOT021Z	
	18.5	VFAS3-2185P	PFL-2100S			PBR7-008W7R5		FOT021Z	
	22	VFAS3-2220P	PFL-2100S			PBR7-017W3R7		FOT022Z	
	30	VFAS3-2300P	PFL-2150S			PBR7-017W3R7		FOT022Z	
	37	VFAS3-2370P	PFL-2150S			PBR7-035W1R8		FOT022Z	
	45	VFAS3-2450P	PFL-2200S			PBR7-035W1R8		FOT023Z	
	55	VFAS3-2550P	PFL-2300S			PBR7-035W1R8		FOT023Z	
480V	0.4	VFAS3-4004PC	PFL-4012S	Built-in	Built-in	PBR-2007	MSF-4015Z	FOT018Z	
	0.75	VFAS3-4007PC	PFL-4012S			PBR-2007	MSF-4015Z	FOT018Z	
	1.5	VFAS3-4015PC	PFL-4012S			PBR-2007	MSF-4037Z	FOT018Z	
	2.2	VFAS3-4022PC	PFL-4012S			PBR-2007	MSF-4037Z	FOT018Z	
	4.0	VFAS3-4037PC	PFL-4012S			PBR-4037	MSF-4037Z	FOT018Z	
	5.5	VFAS3-4055PC	PFL-4025S			PBR7-004W060	MSF-4075Z	FOT019Z	
	7.5	VFAS3-4075PC	PFL-4025S			PBR7-004W060	MSF-4075Z	FOT019Z	
	11	VFAS3-4110PC	PFL-4025S			PBR7-008W030	MSF-4150Z	FOT020Z	
	15	VFAS3-4150PC	PFL-4050S			PBR7-008W030	MSF-4150Z	FOT020Z	
	18.5	VFAS3-4185PC	PFL-4050S			PBR7-008W030	MSF-4220Z	FOT020Z	
	22	VFAS3-4220PC	PFL-4050S			PBR7-017W015	MSF-4220Z	FOT021Z	
	30	VFAS3-4300PC	PFL-4100S			PBR7-017W015	MSF-4370Z	FOT021Z	
	37	VFAS3-4370PC	PFL-4100S			PBR7-017W010	MSF-4370Z	FOT021Z	
	45	VFAS3-4450PC	PFL-4100S			PBR7-017W7R5	MSF-4550Z	FOT022Z	
	55	VFAS3-4550PC	PFL-4150S			PBR7-017W7R5	MSF-4550Z	FOT022Z	
	75	VFAS3-4750PC	PFL-4150S			PBR7-017W3R7	MSF-4750Z	FOT022Z	
	90	VFAS3-4900PC	PFL-4300S			PBR7-4132K	DGP600W-B2M/C2M	FN5040-410-99	FOT023Z
	110	VFAS3-4110KPC	PFL-4300S			PBR7-4132K	DGP600W-B2M/C2M	FN5040-410-99	FOT023Z
	132	VFAS3-4132KPC	PFL-4400S			PBR7-4132K	DGP600W-B2M/C2M	FN5040-410-99	FOT023Z
	160	VFAS3-4160KPC	PFL-4400S			Built-in	DGP600W-B2M/C2M	FN5040-480-99	FOT013Z
200	VFAS3-4200KPC	PFL-4600S	PBR7-4200K	DGP600W-B3M/C3M	FN5040-480-99	FOT014Z/FOT015Z			
220	VFAS3-4220KPC	PFL-4600S	PBR7-4200K	DGP600W-B3M/C3M	FN5040-750-99	FOT014Z/FOT015Z			
280	VFAS3-4280KPC	PFL-4800S	PBR7-4200K	DGP600W-B4M/C4M	FN5040-750-99	FOT014Z/FOT015Z			

External options for ND rating

Voltage class	Applicable motor(kW)	Drive type-form	Input AC reactor (ACL)	DC reactor (DCL)	Braking unit	Braking resistor	Motor-end surge voltage suppression filter	Flange mounting kit	
240V	0.75	VFAS3-2004P	PFL-2005S	Built-in	Built-in	PBR-2007	-	FOT018Z	
	1.5	VFAS3-2007P	PFL-2011S			PBR-2022		FOT018Z	
	2.2	VFAS3-2015P	PFL-2011S			PBR-2022		FOT018Z	
	4.0	VFAS3-2022P	PFL-2018S			PBR-2037		FOT018Z	
	5.5	VFAS3-2037P	PFL-2025S			PBR7-004W015		FOT019Z	
	7.5	VFAS3-2055P	PFL-2050S			PBR7-004W015		FOT020Z	
	11	VFAS3-2075P	PFL-2050S			PBR7-008W7R5		FOT020Z	
	15	VFAS3-2110P	PFL-2100S			PBR7-008W7R5		FOT021Z	
	18.5	VFAS3-2150P	PFL-2100S			PBR7-008W7R5		FOT021Z	
	22	VFAS3-2185P	PFL-2100S			PBR7-008W7R5		FOT021Z	
	30	VFAS3-2220P	PFL-2150S			PBR7-017W3R7		FOT022Z	
	37	VFAS3-2300P	PFL-2150S			PBR7-035W1R8		FOT022Z	
	45	VFAS3-2370P	PFL-2200S			PBR7-035W1R8		FOT022Z	
	55	VFAS3-2450P	PFL-2300S			PBR7-035W1R8		FOT023Z	
	75	VFAS3-2550P	PFL-2400S			PBR7-4132K		DGP600W-B1M/C1M	FOT023Z
480V	0.75	VFAS3-4004PC	PFL-4012S	Built-in	Built-in	PBR-2007	MSF-4015Z	FOT018Z	
	1.5	VFAS3-4007PC	PFL-4012S			PBR-2007	MSF-4015Z	FOT018Z	
	2.2	VFAS3-4015PC	PFL-4012S			PBR-2007	MSF-4037Z	FOT018Z	
	4.0	VFAS3-4022PC	PFL-4012S			PBR-4037	MSF-4037Z	FOT018Z	
	5.5	VFAS3-4037PC	PFL-4025S			PBR7-004W060	MSF-4075Z	FOT018Z	
	7.5	VFAS3-4055PC	PFL-4025S			PBR7-004W060	MSF-4075Z	FOT019Z	
	11	VFAS3-4075PC	PFL-4025S			PBR7-008W030	MSF-4150Z	FOT019Z	
	15	VFAS3-4110PC	PFL-4050S			PBR7-008W030	MSF-4150Z	FOT020Z	
	18.5	VFAS3-4150PC	PFL-4050S			PBR7-008W030	MSF-4220Z	FOT020Z	
	22	VFAS3-4185PC	PFL-4050S			PBR7-008W030	MSF-4220Z	FOT020Z	
	30	VFAS3-4220PC	PFL-4100S			PBR7-017W015	MSF-4370Z	FOT021Z	
	37	VFAS3-4300PC	PFL-4100S			PBR7-017W015	MSF-4370Z	FOT021Z	
	45	VFAS3-4370PC	PFL-4100S			PBR7-017W010	MSF-4550Z	FOT021Z	
	55	VFAS3-4450PC	PFL-4150S			PBR7-017W7R5	MSF-4550Z	FOT022Z	
	75	VFAS3-4550PC	PFL-4150S			PBR7-017W3R7	MSF-4750Z	FOT022Z	
	90	VFAS3-4750PC	PFL-4300S			PBR7-4132K	DGP600W-B2M/C2M	FN5040-410-99	FOT022Z
	110	VFAS3-4900PC	PFL-4300S			PBR7-4132K	DGP600W-B2M/C2M	FN5040-410-99	FOT023Z
	132	VFAS3-4110KPC	PFL-4400S			PBR7-4132K	DGP600W-B2M/C2M	FN5040-410-99	FOT023Z
	160	VFAS3-4132KPC	PFL-4400S			Built-in	DGP600W-B2M/C2M	FN5040-480-99	FOT013Z
	220	VFAS3-4200KPC	PFL-4600S			PBR7-4200K	DGP600W-B4M/C4M	FN5040-750-99	FOT014Z/FOT015Z
250	VFAS3-4200KPC	PFL-4800S	PBR7-4200K	DGP600W-B4M/C4M	FN5040-750-99	FOT014Z/FOT015Z			
280	VFAS3-4220KPC	PFL-4800S	PBR7-4200K	DGP600W-B4M/C4M	FN5040-1200-99	FOT014Z/FOT015Z			
315	VFAS3-4280KPC	PFL-4800S	PBR7-4200K	DGP600W-B4M/C4M	FN5040-1200-99	FOT014Z/FOT015Z			

Input AC reactor

External dimensions

Fig.A

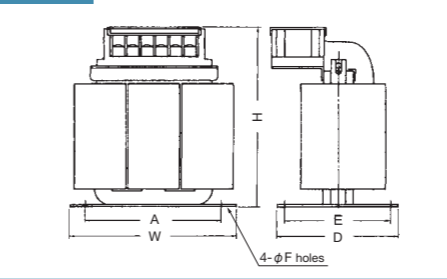

Fig.B

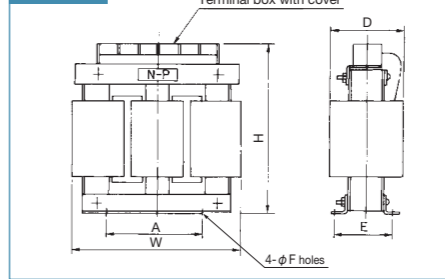

Fig.C

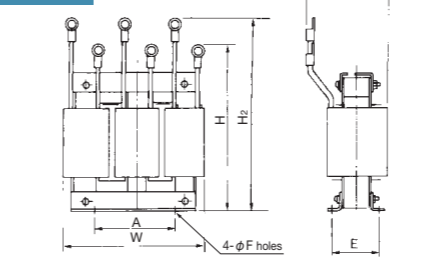

Fig.D

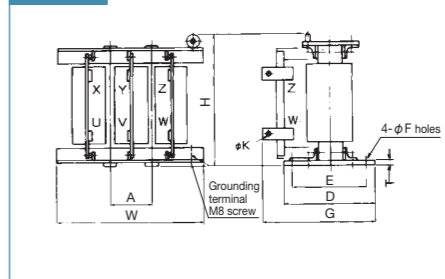
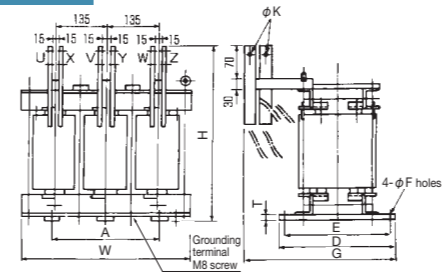
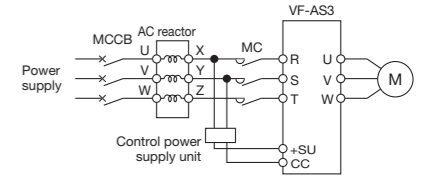
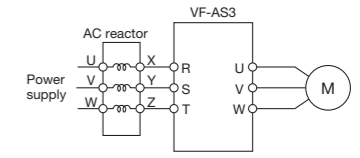

Fig.E



Connection diagram



In case of using control power supply unit (option)

Model	Rating	Drive type-form	Dimensions(mm)										External dimension diagram	Terminals	Approx. mass (kg)
			W	H	D	H2	A	E	F	G	T	K			
PFL-2005S	3φ-230V-5.5A-50/60Hz	VFAS3-2004P(HD), 2007P(HD) VFAS3-2004P(ND)	105	115	72.5	-	90	55	5	-	-	-	A	Terminal block M3.5	1.2
PFL-2011S	3φ-230V-11A-50/60Hz	VFAS3-2015P(HD), 2022P(HD) VFAS3-2007P(ND), 2015P(ND)	130	140	85	-	115	60	5	-	-	-	A	Terminal block M4	2.3
PFL-2018S	3φ-230V-18A-50/60Hz	VFAS3-2037P(HD), VFAS3-2022P(ND)	130	140	85	-	115	60	5	-	-	-	A	Terminal block M4	2.5
PFL-2025S	3φ-230V-25A-50/60Hz	VFAS3-2055P(HD), VFAS3-2037P(ND)	125	130	100	-	50	83	7	-	-	-	A	Terminal block M4	2.6
PFL-2050S	3φ-230V-50A-50/60Hz	VFAS3-2075P(HD), 2110P(HD) VFAS3-2055P(ND), 2075P(ND)	155	140	115	-	50	95	7	-	-	-	B	Terminal block M6	3.4
PFL-2100S	3φ-230V-100A-50/60Hz	VFAS3-2150P(HD), 2185P(HD), 2220P(HD) VFAS3-2110P(ND), 2150P(ND), 2185P(ND)	230	210	150	-	60	90	8	-	-	-	B	Terminal block M8	8.2
PFL-2150S	3φ-230V-150A-50/60Hz	VFAS3-2300P(HD), 2370P(HD) VFAS3-2220P(ND), 2300P(ND)	175	220	160	290	60	110	8	-	-	-	C	Ring terminal 60-10	11.3
PFL-2200S	3φ-230V-200A-50/60Hz	VFAS-2450P(HD), VFAS3-2370P(ND)	195	240	170	320	65	115	10	-	-	-	C	Ring terminal 80-10	15.1
PFL-2300S	3φ-230V-300A-50/60Hz	VFAS3-2550P(HD), VFAS3-2450P(ND)	235	280	200	370	75	128	10	-	-	-	C	Ring terminal 150-10	23.1
PFL-2400S	3φ-230V-400A-50/60Hz	VFAS3-2550P(ND)	260	330	230	-	90	200	12	300	9	13	D	φ13	30
PFL-4012S	3φ-460V-12.5A-50/60Hz	VFAS3-4004PC(HD) to VFAS3-4037PC(HD) VFAS3-4004PC(ND) to VFAS3-4022PC(ND)	125	130	95	-	50	79	7	-	-	-	B	Terminal block M4	2.3
PFL-4025S	3φ-460V-25A-50/60Hz	VFAS3-4055PC(HD) to VFAS3-4110PC(HD) VFAS3-4037PC(ND) to VFAS3-4075PC(ND)	155	155	110	-	50	94	7	-	-	-	B	Terminal block M4	4.9
PFL-4050S	3φ-460V-50A-50/60Hz	VFAS3-4150PC(HD) to VFAS3-4220PC(HD) VFAS3-4110PC(ND) to VFAS3-4185PC(ND)	155	165	140	-	50	112	7	-	-	-	B	Terminal block M6	6.6
PFL-4100S	3φ-460V-100A-50/60Hz	VFAS3-4300PC(HD) to VFAS3-4450PC(HD) VFAS3-4220PC(ND) to VFAS3-4370PC(ND)	235	250	170	-	75	105	10	-	-	-	B	Terminal block M8	17.6
PFL-4150S	3φ-460V-150A-50/60Hz	VFAS3-4550PC(HD), 4750PC(HD) VFAS3-4450PC(ND), 4550PC(ND)	235	280	190	360	75	115	10	-	-	-	C	Ring terminal 80-10	20.3
PFL-4300S	3φ-460V-300A-50/60Hz	VFAS3-4900PC(HD), 4110KPC(HD) VFAS3-4750PC(ND), 4900PC(ND)	260	380	230	-	90	200	12	280	9	13	D	φ13	38
PFL-4400S	3φ-460V-400A-50/60Hz	VFAS3-4132KPC(HD), 4160KPC(HD) VFAS3-4110KPC(ND), 4132KPC(ND)	260	380	230	-	90	200	12	300	9	13	D	φ13	42
PFL-4600S	3φ-460V-600A-50/60Hz	VFAS3-4200KPC(HD), 4220KPC(HD) VFAS3-4160KPC(ND)	440	465	290	-	280	250	15	445	12	18	E	φ18	75
PFL-4800S	3φ-460V-800A-50/60Hz	VFAS3-4280KPC(HD) VFAS3-4200KPC(ND) to VFAS3-4280KPC(ND)	440	540	290	-	280	250	15	445	12	18	E	φ18	90

Motor end surge voltage suppression filter (Only 480V class)

External dimensions

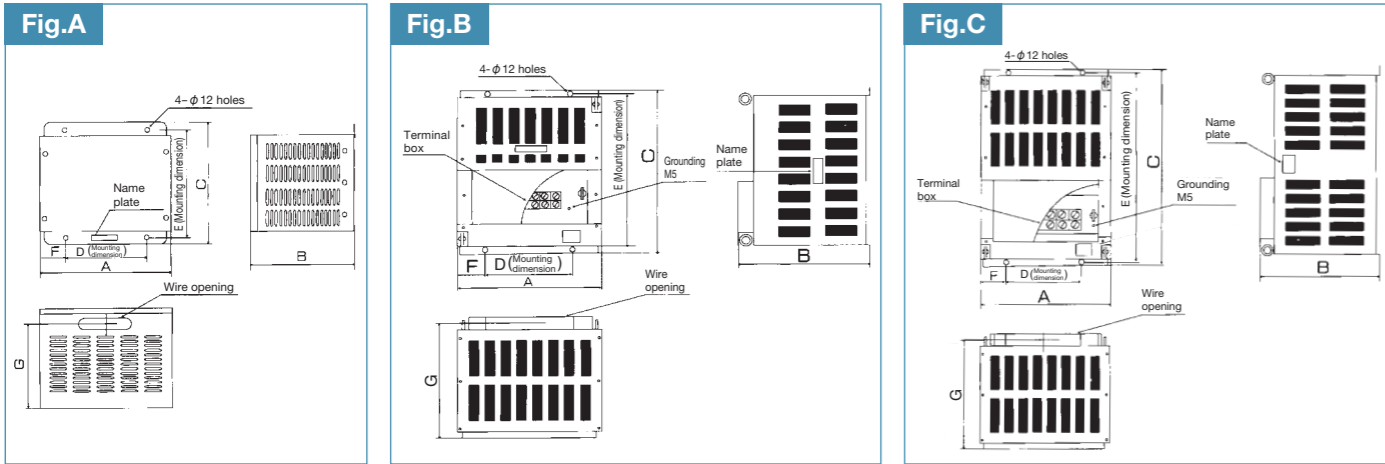

Connection diagram

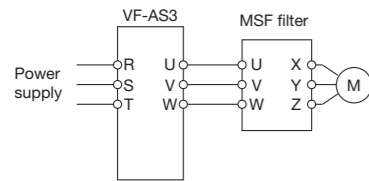

Countermeasure of motor end surge voltage

At the system of operation of the 480V class motor by the voltage type PWM drive with using super high-speed switching device(ex.IGBT), the degradation of insulation of motor wiring may be occurred by the length conditions of the cable, laid down of the cable and the constants of the cable.

In this case, the following countermeasures are suggested.

- 1) Use of the enhanced insulation type of motor
- 2) Suppress the surge voltage by AC reactors in the load side or surge suppression filter.

Note 1) To be installed floor horizontal mounting.

Note 2) To be used that carrier frequency is 15kHz or less, and output frequency is 60Hz or less.

Model	Drive type-form	Dimensions (mm)							External dimension diagram	Terminal screw	Approx. mass (kg)
		A	B	C	D	E	F	G			
MSF-4015Z	VFAS3-4004PC(HD) to VFAS3-4015PC(HD) VFAS3-4004PC(ND), 4007PC(ND)	310	255	300	200	270	55	189	A	M4	12
MSF-4037Z	VFAS3-4022PC(HD), 4037PC(HD) VFAS3-4015PC(ND), 4022PC(ND)	310	255	300	200	270	55	209		M4	20
MSF-4075Z	VFAS3-4055PC(HD), 4075PC(HD) VFAS3-4037PC(ND), 4055PC(ND)	310	315	350	200	320	55	249		M5	30
MSF-4150Z	VFAS3-4110PC(HD), 4150PC(HD) VFAS3-4075PC(ND), 4110PC(ND)	330	350	400	200	370	65	289		M6	40
MSF-4220Z	VFAS3-4185PC(HD), 4220PC(HD) VFAS3-4150PC(ND), 4185PC(ND)	330	400	400	200	370	65	279	B	M6	52
MSF-4370Z	VFAS3-4300PC(HD), 4370PC(HD) VFAS3-4220PC(ND), 4300PC(ND)	426	375	512	260	490	83	350			
MSF-4550Z	VFAS3-4450PC(HD), 4550PC(HD) VFAS3-4370PC(ND), 4450PC(ND)	450	395	632	260	610	95	365	C	M10	110
MSF-4750Z	VFAS3-4750PC(HD) VFAS3-4550PC(ND)	450	415	700	260	678	95	385			

Reactor

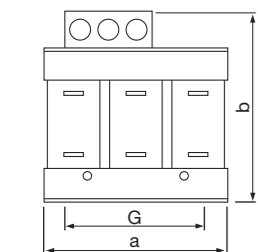

Capacitor

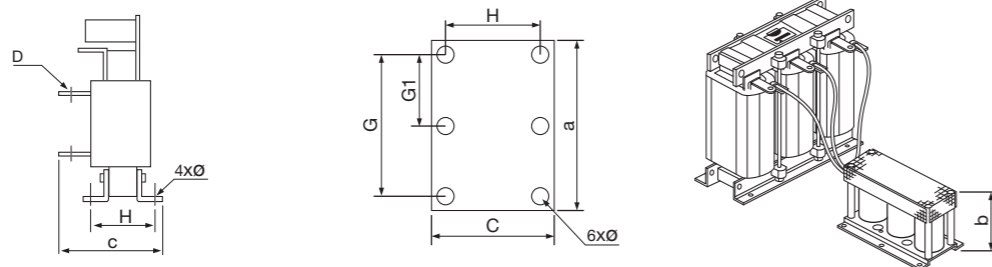

Model	Drive type-form	Dimensions (mm)													Approx. mass (kg)			
		Reactor							Capacitor						Reactor	Capacitor	Total	
a	b	c	G	H	φ	D	a	b	c	G	G1	H	φ	Reactor	Capacitor	Total		
FN5040-410-99	VFAS3-4900PC(HD) to VFAS3-4132KPC(HD) VFAS3-4750PC(ND) to VFAS3-4110KPC(ND)	490	600	355	430	194	10.6x18.6	2xφ13.5	328	240	170	300	150	150	9	169	8	177
FN5040-480-99	VFAS3-4160KPC(HD), 4200KPC(HD) VFAS3-4132KPC(ND), 4160KPC(ND)	510	618	410	430	195	13x27	2xφ13.5	328	220	270	300	150	250	9	210	10	220
FN5040-750-99	VFAS3-4220KPC(HD), 4280KPC(HD) VFAS3-4200KPC(ND), 4220KPC(ND)	660	670	468	570	220	13x26	2xφ13.5	555	200	375	510	255	350	9	430	25	455
FN5040-1200-99	VFAS3-4280KPC(ND)	748	925	440	570	220	13x26	2xφ13.5	665	205	375	620	310	350	9	630	35	665

Braking resistor

Braking resistor (PBR)

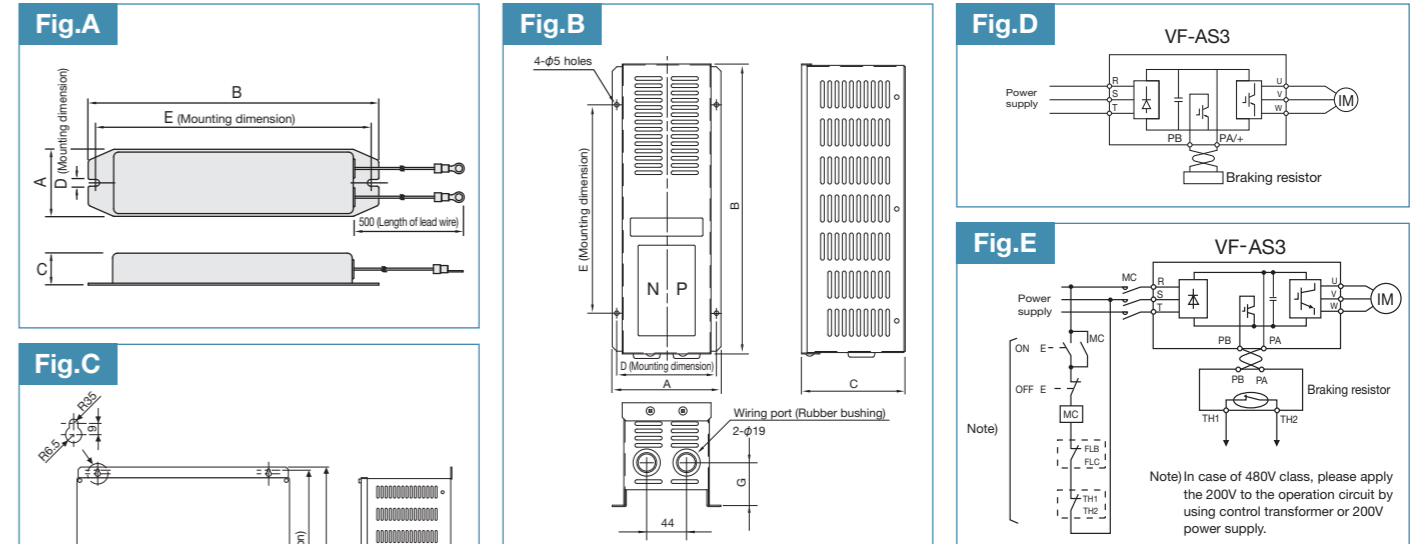

Type	Model	Dimensions (mm)						Approx. mass (kg)	External dimension diagram	Connection diagram
		A	B	C	D	E	G			
Standard	PBR-2007	42	182	20	4.2	172	-	0.28	A	D
	PBR-2022									
	PBR-2037									
400W class	PBR7-004W	120	320	115	110	230	48	3.4	B	E
1.5kW class	PBR7-017W	240	430	190	190	414	52	10	C	
5kW class	PBR7-052W	395	616	190	320	600	52	29		

Note 1) □□□ in the type-form are numeric character. Please refer to the "Selection of braking resistor" in the next page.

Note 2) The rating shows the synthetic resistor value (Ohm) and the synthetic resistor power (Watt). The word in the parentheses shows the composition of resistor elements.

Note 3) The allowable continuous regenerative power differs on the resistor value or power tolerance. Please refer the "Selection of braking resistor" in the next page.

Braking resistor (DGP600)

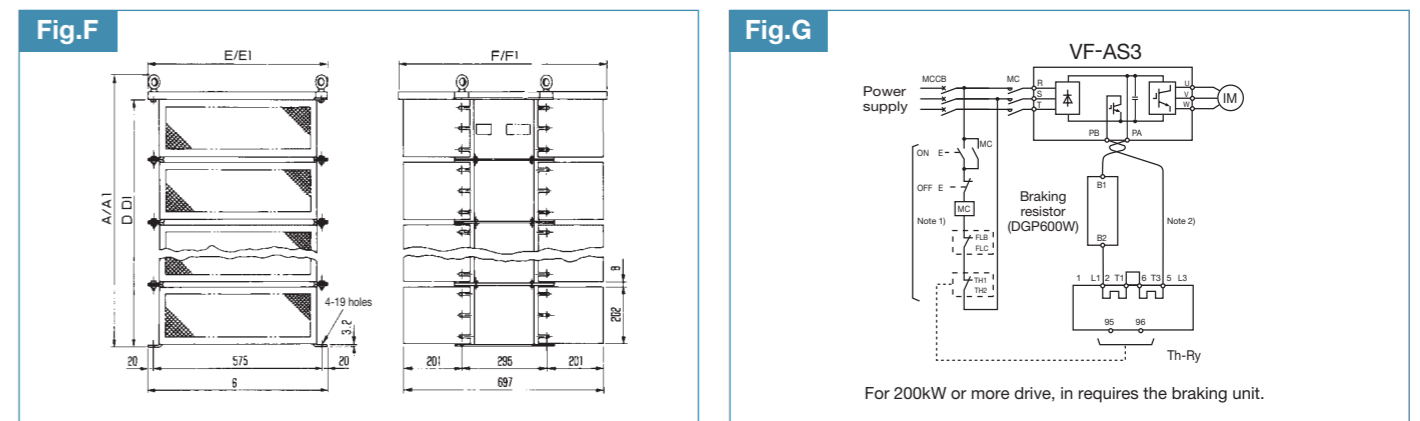

Note 1) In case of 480 V class, please apply the 200V to the operation circuit by using control transformer or 200V power supply.

Note 2) Please twist the wire by 10 cm pitch. The distance between resistor power wiring and the control wiring should be over 20 cm.

Note 3) Please make a short circuit between the 2/T1 and 6/T3 of the thermal relay.

Model	Rating	Dimensions (mm) Note 2)				External dimension diagram	Connection diagram	Thermal relay (Th-Ry) Setting value (A)	Approx. mass (kg)
		A/A1	D/D1	E/E1	F/F1				
DGP600W-B1	1.7Ω-3.4kW	283/303	207/192	620/700	725/780	F	G	46	50
DGP600W-B2	3.7Ω-7.4kW	493/513	417/402	620/700	725/780			44	100
DGP600W-B3	1.9Ω-8.7kW	703/723	627/612	620/700	725/780			71	150
DGP600W-B4	2.5Ω-10.5kW	913/933	837/822	620/700	725/780			65	150
	5Ω-10kW							45	150
DGP600W-B4	1.4Ω-14kW							110	200
	1.7Ω-10kW							77	200

Note 1) The braking resistors are designed for indoor type. Please use them with drip cover in case of water drop. But please note it is not for water proof protection type.

Note 2) A, D, E, F are the dimensions of standard type. A1, D1, E1, F1 are the dimensions of those with drip cover type.

For users of the products : Our variable speed drives are designed to control the speeds of three-phase motors for general industry.

 **Precautions**

- * Please read the instruction manual before installing or operating the drive unit.
- * This product is intended for general purpose uses in industrial application. It cannot be used applications where may cause big impact on public uses, such as power plant and railway, and equipment which endanger human life or injury, such as nuclear power control, aviation, space flight control, traffic, safety device, amusement, or medical.
It may be considerable whether to apply, under the special condition or an application where strict quality control may not be required. Please contact our headquarters, branch, or local offices printed on the front and back covers of this catalogue.
- * When exporting Toshiba variable speed drive separately or combined with your equipment, please be sure to satisfy the objective conditions and inform conditions listed in the export control policies, so called Catch All restrictions, which are set by the Ministry of Economy, Trade and Industry of Japan, and the appropriate export procedures must also be taken.
- * Please use our product in applications where do not cause serious accidents or damages even if product is failure, or please use in environment where safety equipment is applicable or a backup circuit device is provided outside the system.
- * Please do not use our product for any load other than three-phase motors.
- * None of Toshiba, its subsidiaries, affiliates or agents, shall be liable for any physical damages, including, without limitation, malfunction, anomaly, breakdown or any other problem that may occur to any apparatus in which the Toshiba variable speed drive is incorporated or to any equipment that is used in combination with the Toshiba variable speed drive. Nor shall Toshiba, its subsidiaries, affiliates or agents be liable for any compensatory damages resulting from such utilization, including compensation for special, indirect, incidental, consequential, punitive or exemplary damages, or for loss of profit, income or data, even if the user has been advised or apprised of the likelihood of the occurrence of such loss or damages.

For further information, please contact your nearest Toshiba Representative or International Operations-Producer Goods. The information in this brochure is subject to change without notice.

TOSHIBA

**Toshiba Industrial Products and
Systems Corporation**

Global Sales Department Motor Drive Division
580, Horikawa-cho, Saiwai-ku,
Kawasaki, Kanagawa 212-0013, Japan
Tel : +81-44-520-0828
Fax : +81-44-520-0508