

# TOSHIBA

TOSHIBA INTERNATIONAL CORPORATION

## ADJUSTABLE SPEED DRIVES

# S15 (HEAVY DUTY)

**LOW  
VOLTAGE**



# EXTREME PERFORMANCE MICRO-DRIVE

Toshiba's heavy duty S15 adjustable speed drive is a compact and high performance drive designed for controlling a wide range of variable and constant torque applications for multiple industries. This micro-drive is capable of working with permanent magnet (PM) motors, which allows a much greater flexibility in selecting a motor for an application. In addition, expanded PID control allows a greater level of precise control and operation of difficult level control applications. No other micro-drive delivers such reliable performance and extensive capabilities at such a competitive cost.



## Compact Design

Separates the S15 from the competition, as one of the smallest drives offered in the industry. The compact design allows the unit to be installed in areas with limited space, allowing users more real estate when running applications.

## Easy Installation and Programming

Allows the user to install and program the S15 drive with minimal downtime. Din Rail kits allow users the option of easily mounting the drive onto a pre-existing DIN inside of a cabinet or on a panel. The addition of the +SU terminal to the S15 allows for the end user to power the drive control section using a simple 24 VDC power supply. This allows startup technicians to program the drive without having to have 230 V, 460 V, or 600 V three-phase power available.

## Tough Environment

Conditions are no problem for the S15. Designed to withstand extreme temperatures, the S15 can operate in temperatures of up to 122°F (50°C) without derating and can also be configured for use in temperatures above 122°F (50°C) with a de-rate.

## Superior Control

Allows the user ultimate application flexibility. Toshiba's advanced vector-control algorithm offers speed regulation of 0.1% sensor-less. Energy saving, user selectable V/Hz patterns make the S15 a smart choice for any application.

## Heavy Duty Performance

Separates the S15 from the competition. Offering one of the toughest micro-drive overload ratings in the industry, the S15 is rated for 110% of its full-load amp rating for continuous operation and 150% for up to one minute.

## ADVANCED FEATURES FOR MAXIMUM DRIVE PERFORMANCE

**Built-In LED Interface** allows for quick, user-friendly programming and easy modification of the S15's expanded parameter set. Additional remote-mount keypads are also available. The parameter write and simple fault tracking functionality of these optional keypads make setup and troubleshooting quick and simple.

**My Function**, Toshiba's Proprietary Programming Feature, allows the user to utilize logic-type programming without the expense of a micro PLC. The user is able to read all analog and digital inputs and outputs as well as monitor and compare data. When programmed in a user-defined logic sequence, the use of this data will allow for a higher level of process control not normally seen in an adjustable speed drive. These functions, along with timers, counters, and comparators, allow the S15 to not only meet but exceed performance expectations.

**S15's Easy Key** is a configurable key that simplifies startup and operation. The easy key quickly accesses commonly changed parameters. In addition, the easy key can also function as a simple local/remote key for easy operation switching.

**Improved PID Control Algorithm** provides regulation of critical processes. High and low speed limits, deviation limits, online switching, and a built-in sleep function are included to enhance the flexibility and reliability of PID process control. Improved control is possible with the S15's enhanced PID algorithm, making it easier than ever to dial in your process control application.

**Toshiba's Proprietary Windows®-Based ASD Pro Software** is available at no additional cost. This easy-to-use software is designed to provide a full range of programming and monitoring tools for all Toshiba low voltage drives, including the S15. ASD Pro offers parameter reading, trending, and logging features that allow the user to save and transfer parameters and export data and graphs to an electronic file. Parameter groups and trending data can be easily converted into spreadsheets or graphs for field and validation reports.

### INDUSTRIES SERVED

- Food & Beverage Processing
- HVAC
- Mining & Minerals
- Oil & Gas
- Water & Wastewater
- Agribusiness

### APPLICATIONS

- Blowers & Compressors
- Machine Tools
- Conveyors
- Irrigation
- Mixers
- Pumps
- Fans
- Lifts

## COMMUNICATION OPTIONS

The S15 drive offers a wide array of easily installed option boards. These boards allow the user to communicate with a wide variety of systems. Options include:

- CANopen
- DeviceNet
- EtherCAT
- Ethernet/IP
- Modbus TCP
- Profibus DP
- PROFINET

## ADDITIONAL OPTIONS

The S15 can be supplied with additional options to expand control, allow greater flexibility, and provide better protection for a user's application. Options include:

- Parameter Writer
- IP54 Packaged Unit (Consult Factory)
- Input Reactor
- DV/dt Long Lead Filter
- NetPac™ Wireless Connection
- Remote Mountable Keypads
- DIN Rail Mounting

## OTHER SPECIAL FEATURES

- Safe Torque Off (STO) Compliant
- Ten Year Long-Life Design
- Rotary Encoder
- Reduced Energy Consumption
- UL Listed & Labeled



MODEL RANGE	1/4 HP to 3 HP	1/2 HP to 20 HP	1/2 HP to 20 HP	2 HP to 20 HP
Voltage Rating	Single-Phase 230 VAC	Three-Phase 230 VAC	Three-Phase 460 VAC	Three-Phase 600 VAC
<b>POWER REQUIREMENTS</b>				
Input Tolerance	Voltage: ±10%; Frequency: ±5%			
Output Frequency	0.1 to 500 Hz			
<b>CONTROL SPECIFICATIONS</b>				
Control Method	Sinusoidal Pulse Width Modulation (PWM); Flux-Field Current Vector Control; Set Point Control (PID)			
Voltage Regulation	Main Circuit Voltage Feedback Control: Automatic, Fixed, & Off			
V/Hz Control	V/f Constant, Variable Torque, Automatic Torque Boost, Vector Control, PM Motor Control, 5-point V/F Custom Setting, & Auto-Tuning			
PWM Carrier Frequency	Adjustable 2 to 16 kHz (For Drive Specific Information Consult Factory)			
Frequency Setting	Rotary Encoder Integrated into EOI, 0 to 10 VDC, ±10VDC, 4 to 20 mA, Digital Input, Binary Input, & Motorized Potentiometer Input			
Frequency Precision	Analog Input ±0.5% of Maximum Output Frequency; Discrete/Communications Input ±0.01% of Maximum Output Frequency			
Speed Regulation	Open Loop: Up to 0.1%, 60:1 Speed Range			
Main Protective Functions	Stall Prevention, Current Limit, Over-Current, Output Short Circuit, Over-Voltage, Over-Voltage Limit, Undervoltage, Ground Fault Detection, Input Phase Failure, Output Phase Failure, Overload Protection by Electronic Thermal Function, Armature Over-Current at Start-Up, Load Side Over-Current at Start-Up, Over-Torque, Undercurrent, Overheating, Cumulative Operation Time, Life Alarm, Emergency Stop, & Various Pre-alarms			
Retry	User-Set Number of Retries for Automatic System Restart After Trip			
Restart	Able to Smoothly Catch Freewheeling Motor (Bidirectional)			
Overload Current Rating	110% Continuous; 150% for One Minute			
<b>CONTROL INTERFACE</b>				
Digital Input	Six Discrete Input Terminals Programmable to 110 Functions (May Be Increased Using Optional Hardware)			
Digital Output	Three Discrete Output Terminals Programmable to 150 Functions; One Form-A Contact, One Form-C Contact, & One Open Collector Output			
Analog Input	Three Programmable: One 4 to 20 mA Input, One 0 to 10 VDC Input, & One ±10 VDC Input			
Analog Output	One Programmable: 4 to 20 mA or 0 to 10 VDC			
Communication Ports	RS485 Port (TSB or MODBUS RTU Protocol)			
<b>ELECTRONIC OPERATOR INTERFACE (EOI)</b>				
Display	Integral Four-Digit & Seven-Segment LED Keypad for Programming, Monitoring, & Diagnostics			
LED Indicator	DC Bus Charge Indicator (Red)			
Keys	Run, Prg, Mon, Status, %, Hz, Stop, Mode, & Easy Key; Rotary Encoder for Parameter Navigation, Settings, & Control			
Monitoring	Frequency Command Screen; Multiple Parameters Displayed: Output Frequency, Forward/Reverse Run, Output Current, Input Voltage (DC Detection), Output Voltage, Torque, Inverter Load Factor, Motor Load Factor, Braking Resistor Load Factor, Input Power, Output Power, Input Terminal status, Output Terminal Status, Overload/Regional Setting, PID Feedback Value, Stator Frequency, Parts Replacement Alarm, Cumulative Operation Time, & Past Trips			
<b>CONSTRUCTION</b>				
Enclosure	RAL 7016 (Anthracite Gray); IP20; Wall-Mount; Front-Access Only			
Power Cables	Bottom Access for Input/Motor Cables			
Cooling	Self-Cooling/ Forced Air-Cooled			
Standards & Compliances	UL Listed in US & Canada, CSA, & CE			
<b>AMBIENT CONDITIONS</b>				
Ambient Temperature	-10° to 60°C (Note: See Manual for Details; Ambient Temperatures Above 40°C May Require a De-Rate)			
Altitude	3300 ft. Above Sea Level (Up to 10,000 ft. with De-Rate)			
Humidity	95% Maximum (Non-Condensing)			
Installation	Indoors; No Direct Sunlight; Protects from Corrosive Gas/Explosive Gas/Flammable Gas/Oil Mist/Dust; Vibration of Less Than 5.9 m/s <sup>2</sup> (10 to 55 Hz)			

© 2019  
Toshiba International Corporation  
Motors & Drives Division  
13131 West Little York Road  
Houston, Texas 77041 USA  
Tel +713-466-0277  
US 1-800-231-1412  
Rev.01ESSENCE2819



**TOSHIBA MOTORS & DRIVES DIVISION**  
Adjustable Speed Drives • Motors • Motor Controls

[www.toshiba.com/tic](http://www.toshiba.com/tic)

**TOSHIBA**  
TOSHIBA INTERNATIONAL CORPORATION

## 2.2.1 Standard connection diagram 1

This diagram shows a standard wiring of the main circuit.

Standard connection diagram - SINK (Negative) (common:CC)

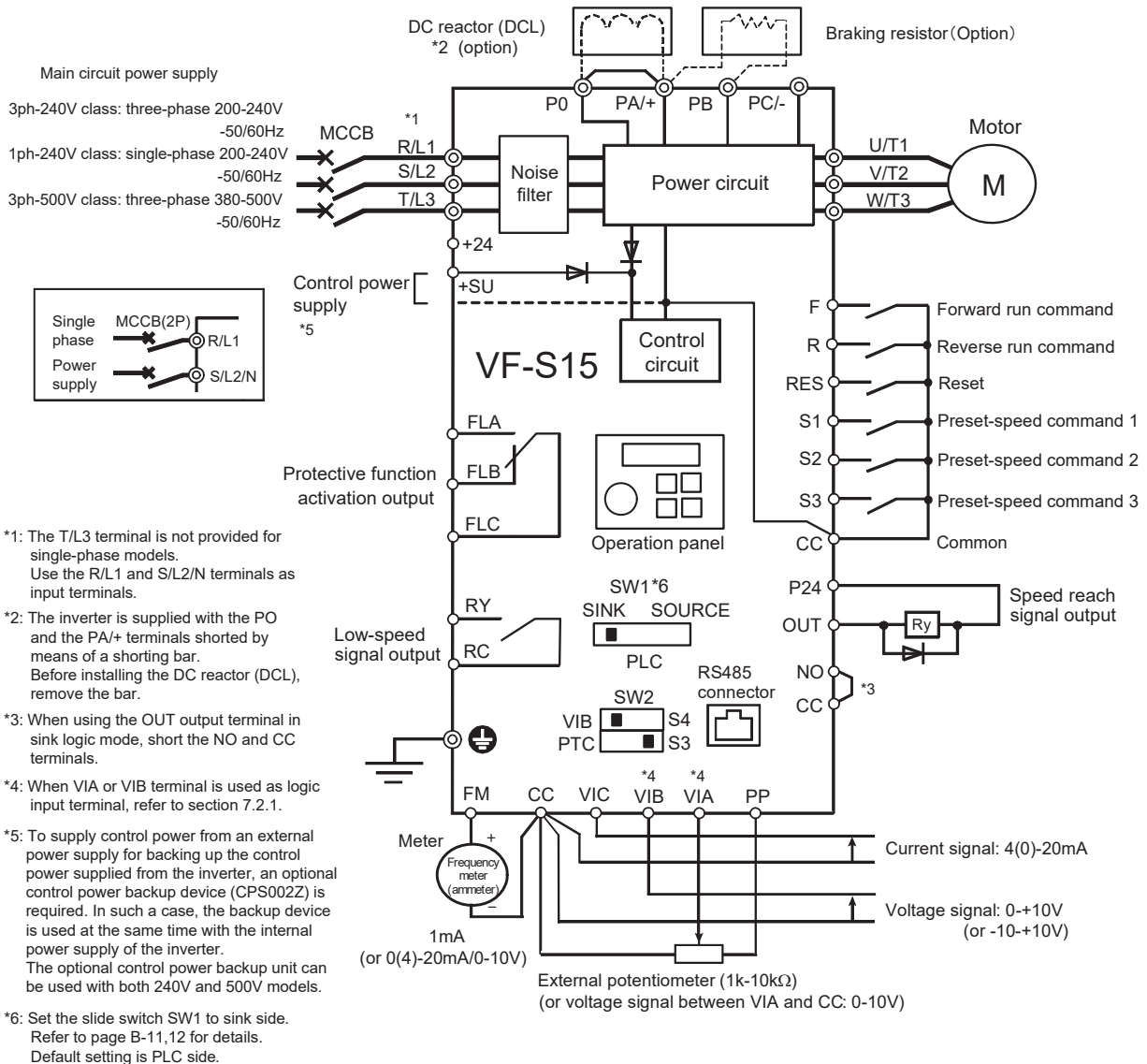

図面番号 DRAWING NO. **M0720899**

車番 車番 REV. MARK **(3)**

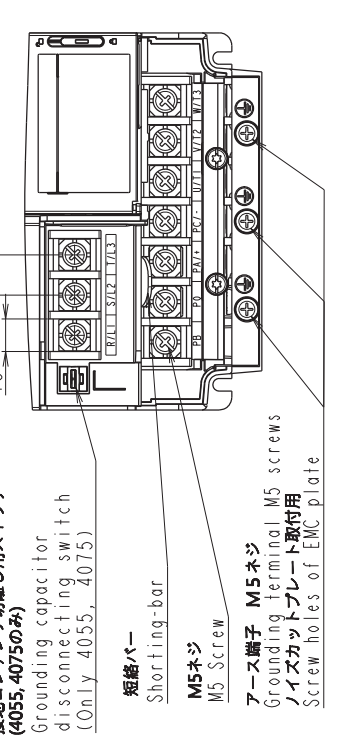
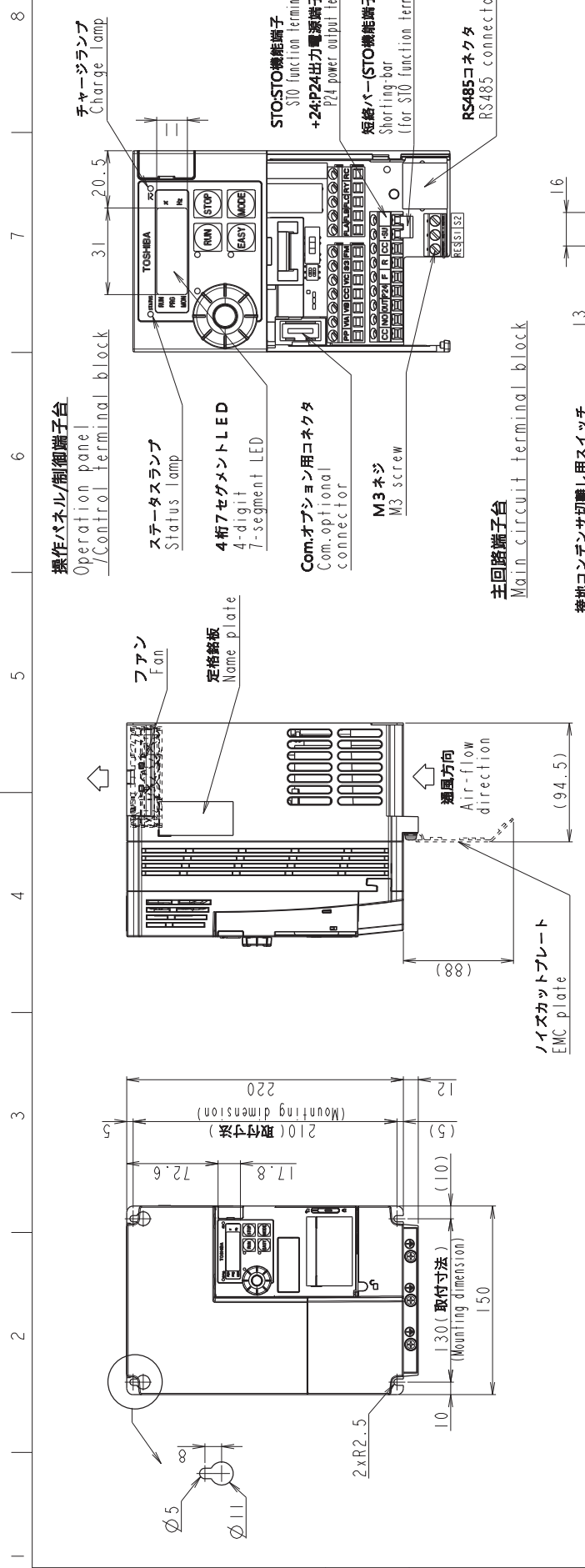

形式	概略質量 (kg)
VFS15-4055PL	3.9
VFS15-4075PL	4.0
VFS15-6055P	3.6
VFS15-6075P	3.7

本体色: グレイ RAL7016  
Box color: GREY RAL7016

INVERTER	VFS15	4055PL, 4075PL, 6055P, 6075P
器具名称	型式	FORM
APPROVED BY	CHECKED BY	
K. Furuhashi	S. Fujimori	
23, Jan, 2012	20, Jan, 2012	
設計 DESIGNED BY	製図 DRAWN BY	
Y. Ho	Y. Ho	
20, Jan, 2012	20, Jan, 2012	
TOSHIBA		
東芝エレクトロニクス株式会社 Toshiba Schneider Inverter Corporation		
図面番号 DRAWING NO. <b>M0720899</b>		
REV. MARK <b>(3)</b>		

記号	2	24, May, 2012	承認 APPROVED BY	名称 TITLE
年月日 DATE	6, Aug, 2013	24, May, 2012	K. Furuhashi	インバータ外形図
承認 APPROVED BY	K. Ohita	24, May, 2012	M. Takeuchi	OUTLINE OF INVERTER
変更者 REVISED BY	S. Oi	24, May, 2012	Y. Ho	TOSVERT VF-ST5 SERIES
変更理由 CHG DESCRIPTION	Add Dimension.			
記事 CONTENTS				
保管 REGISTERED				

図面番号 DRAWING NO. **M0720899**

REV. MARK **(3)**

配布先 PRESENT TO **000008**