

# CSNV500 SERIES

005997  
Issue 4

## Closed Loop Current Sensors

### DESCRIPTION

The CSNV500 Series are Hall-effect, closed loop current sensors that use Honeywell patented technology to bring an enhanced combination of performance and reliability. They are non-intrusive and electrically isolated from the monitored circuit. This can ensure a simple and reliable structure without loss of power to the monitored circuit. The CSNV500 Series are rated for a primary current measurement range of  $\pm 500$  A dc. They are calibrated and temperature compensated for improved accuracy using multi-point temperature characterization.

### DIAGNOSTIC FUNCTIONALITY/ CAN OUTPUT

The CAN output of the CSNV500 Series provides fault detection and communication capability. Also, the digital CAN communication is immune to electrical interference. Examples of sensor and host system faults include:

- Sensor fault
- Supply voltage over range
- Supply voltage under range

### CUSTOMIZATION

The CSNV500 Series may be customized to better meet application needs. Solutions may be tailored to exact specifications for improved time to market, lower total system costs and enhanced reliability. For technical assistance, we provide global engineering and service support for your needs.

### DIFFERENTIATION

- **Accuracy:** Multi-point temperature characterization and calibration for improved accuracy over temperature range
- **Magnetic immunity:** Closed loop configuration and optimized magnetic circuit allow for enhanced performance in diverse magnetic environments
- **Flexible:** Customizable on-board firmware to meet specific application requirements

### VALUE TO CUSTOMERS

- **Accurate:** Designed to enable precise battery state measurement for improved user experience
- **Ease of use:** Magnetic immunity allows for easy integration into different magnetic environments
- **Easy system integration:** CAN communication is transmitted using international road vehicle standard ISO 11898. CAN 2.0A is the default protocol

### INDUSTRIAL APPLICATIONS

- Current measurement for battery management systems in electrified vehicles (EV, HEV, PHEV, BEV)
- Current leakage detection and fault isolation in charging systems
- Current measurement in energy storage systems
- Fault detection in heavy industrial equipment



### FEATURES

- Active closed loop current sensing using Hall-effect technology
- Utilizes proprietary Honeywell technology for temperature compensation
- High accuracy and low temperature drift
- Operating temperature of  $-40^{\circ}\text{C}$  to  $85^{\circ}\text{C}$  [ $-40^{\circ}\text{F}$  to  $185^{\circ}\text{F}$ ]
- Digital output: CAN bus output with selectable ID
- Internal diagnostic function
- Different configuration options: Mounting type, baud rate, CAN ID
- UL, CE, and UKCA certifications; REACH and RoHS compliant

### PORTFOLIO

Honeywell offers a variety of current sensors for potential use in many applications. To view the entire product portfolio, [click here](#).

**Honeywell**

# CLOSED LOOP CURRENT SENSORS

## CSNV500 SERIES

**TABLE 1. ABSOLUTE MAXIMUM RATINGS (not operating)**

Characteristic	Symbol	Unit	Parameter	Condition
Load dump over voltage	$V_S$	V	32	400 mSec
Over voltage	$V_S$	V	24 20	10 min continuous
Reverse polarity	$V_S$	V	-24	10 min
Supply voltage: minimum maximum	$V_S$	V	6 18	—
CAN operation: supply voltage under range alarm, no measurement supply voltage over range alarm, no measurement	—	V	6 to 7 18 to 24	CAN continuous
Insulation resistance	IR	M $\Omega$	>500	500 Vdc at 1 min
Creepage distance	$D_{CP}$	mm	7,5	—
Clearance	$D_{CL}$	mm	7	—
RMS voltage: ac isolation voltage dc isolation voltage	—	kV	5 5	50 Hz, 1 min 1 min

**TABLE 2. OPERATING CHARACTERISTICS IN NOMINAL RANGE ( $I_{PN}$ )**

Characteristic	Symbol	Unit	Specification			Condition
			Min.	Typ.	Max.	
Primary current, nominal measuring range (dc)	$I_{PN}$	A	-500	—	500	full temperature range
Supply voltage	$V_S$	V	7	12	18	full accuracy
Supply voltage hysteresis: maximum	$V_{UP}$	V	—	18.1	—	when $V_S$ increases
	$V_{UP}$	V	—	17.7	—	when $V_S$ decreases
minimum	$V_{LOW}$	V	—	7.1	—	when $V_S$ increases
	$V_{LOW}$	V	—	6.8	—	when $V_S$ decreases
Current consumption: at $I_p = 0$ A at $I_p = 500$ A at $I_p = 500$ A	$I_C$	mA	— — —	21 140 —	40 — 250	$V_S = 12$ V, $T = 25^\circ\text{C}$ $V_S = 12$ V, $T = 25^\circ\text{C}$ $V_S = 7$ V to 18 V, $T = 40^\circ\text{C}$ to $85^\circ\text{C}$
Ambient operating temperature	$T_a$	$^\circ\text{C}$	-40	—	85	temperature range with accuracy guaranteed
Total accuracy at $\pm 40$ A < $I_p \leq \pm 500$ A	$X_G$	%reading	-0.5	—	0.5	$T = -40^\circ\text{C}$ to $85^\circ\text{C}$ , $\pm 3$ sigma
Error at $I_p = 0$ A (offset current)	$I_{OS}$	A	-0.1	—	0.1	$T = -40^\circ\text{C}$ to $85^\circ\text{C}$ , $\pm 3$ sigma
Error at $0$ A < $I_p \leq \pm 40$ A	$I_{OS}$	A	-0.2	—	0.2	$T = -40^\circ\text{C}$ to $85^\circ\text{C}$ , $\pm 3$ sigma
Linearity	$\epsilon_L$	%	—	$\pm 0.1$	—	room temperature
Temperature coefficient	TCG	ppm/ $^\circ\text{C}$	—	10	—	—

**TABLE 3. MECHANICAL CHARACTERISTICS**

Characteristic	Description
Housing material	Plastic PBT+ GF30 %
Mounting screw	M6, torque max. 3 N m The installation bracket should have a flatness tolerance of $\leq 0,2$ mm. The size tolerances of the installation bracket and nut, as well as the use of installation tools and fixtures, have an impact on the maximum installation torque of the product. If there are any relevant design or process changes, it is advisable to implement them after verification.

# CLOSED LOOP CURRENT SENSORS

## CSNV500 SERIES

**TABLE 4. CANBUS CHARACTERISTICS<sup>1, 2, 3, 4</sup>**

Message Description	Can ID	Data Length	Message Launch Type	Signal Description	Signal Name	Start Bit	Length
Output current I <sub>p</sub> (mA)	See Figure 1	8 bytes	Cyclic transmitted message 10 mSec cycle	I <sub>p</sub> value: 80000000h = 0 mA 7FFFFFFFh = -1 mA 80000001h = 1 mA	IP_VALUE	24	32
				Error information	ERROR_INFORMATION	32	7
				Error indication (1 bit): 0 = normal 1 = failure	ERROR_INDICATION	39	1
				Fixed to 0	VACANT_DATA_2BYTES	48	16
				CRC-8 POLY: 8 + X <sup>2</sup> + X + 1	CRC_8	56	8

<sup>1</sup> CANBUS speed: Refer to Figure 1

<sup>2</sup> CAN bus protocol: Version 2.0A

<sup>3</sup> CAN oscillator tolerance: 0.3125%

<sup>4</sup> Byte order: big endian (Motorola)

**TABLE 5. DIAGNOSTIC TROUBLE CODES**

Failure Mode	I <sub>p</sub> VALUE	Error Indication	Error Information
Flash CRC error	FFFF FFFFh	1	0x48
AFE overrange	FFFF FFFFh	1	0x49
AFE Error	FFFF FFFFh	1	0x50
Internal LUT error	FFFF FFFFh	1	0x51
Power minimum limit	FFFF FFFFh	1	0x54
Power maximum limit	FFFF FFFFh	1	0x55

# CLOSED LOOP CURRENT SENSORS

## CSNV500 SERIES

TABLE 6. ORDER GUIDE	
Catalog Listing	Description
<b>CSNV500M-124</b>	CSNV500 Series Hall-based closed loop current sensors, 500 A, through-hole, 250 k baud rate, 3C4 CAN ID
<b>CSNV500M-125</b>	CSNV500 Series Hall-based closed loop current sensors, 500 A, through-hole, 250 k baud rate, 3C5 CAN ID
<b>CSNV500M-126</b>	CSNV500 Series Hall-based closed loop current sensors, 500 A, through-hole, 250 k baud rate, 3C6 CAN ID
<b>CSNV500M-324</b>	CSNV500 Series Hall-based closed loop current sensors, 500 A, through-hole, 250 k baud rate, 3C4 CAN ID
<b>CSNV500M-325</b>	CSNV500 Series Hall-based closed loop current sensors, 500 A, through-hole, 250 k baud rate, 3C5 CAN ID
<b>CSNV500M-326</b>	CSNV500 Series Hall-based closed loop current sensors, 500 A, through-hole, 250 k baud rate, 3C6 CAN ID
<b>CSNV500M-154</b>	CSNV500 Series Hall-based closed loop current sensors, 500 A, through-hole, 500 k baud rate, 3C4 CAN ID
<b>CSNV500M-155</b>	CSNV500 Series Hall-based closed loop current sensors, 500 A, through-hole, 500 k baud rate, 3C5 CAN ID
<b>CSNV500M-156</b>	CSNV500 Series Hall-based closed loop current sensors, 500 A, through-hole, 500 k baud rate, 3C6 CAN ID
<b>CSNV500N-154</b>	CSNV500 Series Hall-based closed loop current sensors, 500 A, through-hole with metal bushing, 500 k baud rate, 3C4 CAN ID
<b>CSNV500N-155</b>	CSNV500 Series Hall-based closed loop current sensors, 500 A, through-hole with metal bushing, 500 k baud rate, 3C5 CAN ID
<b>CSNV500N-156</b>	CSNV500 Series Hall-based closed loop current sensors, 500 A, through-hole with metal bushing, 500 k baud rate, 3C6 CAN ID
<b>CSNV500M-354M</b>	CSNV500 Series Hall-based closed loop current sensors, 500 A, through-hole, 500 k baud rate, 3C4 CAN ID with CAN termination 120 $\Omega$
<b>CSNV500M-355M</b>	CSNV500 Series Hall-based closed loop current sensors, 500 A, through-hole, 500 k baud rate, 3C5 CAN ID with CAN termination 120 $\Omega$
<b>CSNV500M-356M</b>	CSNV500 Series Hall-based closed loop current sensors, 500 A, through-hole, 500 k baud rate, 3C6 CAN ID with CAN termination 120 $\Omega$
<b>CSNV500N-354M</b>	CSNV500 Series Hall-based closed loop current sensors, 500 A, through-hole with metal bushing, 500 k baud rate, 3C4 CAN ID with CAN termination 120 $\Omega$
<b>CSNV500N-355M</b>	CSNV500 Series Hall-based closed loop current sensors, 500 A, through-hole with metal bushing, 500 k baud rate, 3C5 CAN ID with CAN termination 120 $\Omega$
<b>CSNV500N-356M</b>	CSNV500 Series Hall-based closed loop current sensors, 500 A, through-hole with metal bushing, 500 k baud rate, 3C6 CAN ID with CAN termination 120 $\Omega$

# CLOSED LOOP CURRENT SENSORS CSNV500 SERIES

Figure 1. Nomenclature

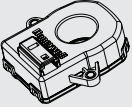
	<b>CS</b>	<b>N</b>	<b>V</b>	<b>500</b>	<b>M</b>	<b>1</b>	<b>5</b>	<b>4</b>	<b>M</b>
	Type	Principle	Use	Rated Current	Mounting Type	MCU Type <sup>1</sup>	Baud Rate	CAN ID <sup>2</sup>	Customization <sup>3</sup>
<b>Current Sensor</b>	<b>N</b>	Hall-based close loop	<b>V</b> Designed for vehicle applications	<b>500</b> 500 A	Through hole	<b>1</b> MCU1	<b>2</b> 250 k	<b>4</b> 3C4	<b>M</b> Without CAN termination
					<b>M</b> 	<b>3</b> MCU2	<b>5</b> 500 k	<b>5</b> 3C5	
					Through-hole with metal bushing			<b>6</b> 3C6	
					<b>N</b> 				

<sup>1</sup> The MCU1 version is a drop-in replacement for the MCU2 version. There is no change to product fit, form or function. The MCU options improve material supply. The CAN termination "M" is validated with MCU2 now.

<sup>2</sup> Custom CAN IDs are available. Contact Honeywell Customer Service for more information

<sup>3</sup> Custom CAN layouts are available. Contact Honeywell Customer Service for more information.

Figure 2. Positive Primary Current Direction (Polarity)

Application condition: Pollution degree PD2

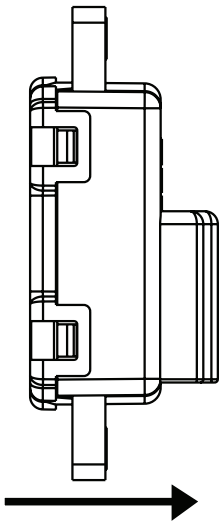

# CLOSED LOOP CURRENT SENSORS CSNV500 SERIES

Figure 3. Dimensional Drawings (For reference only: mm/[in])

## Mounting type M: Through-hole

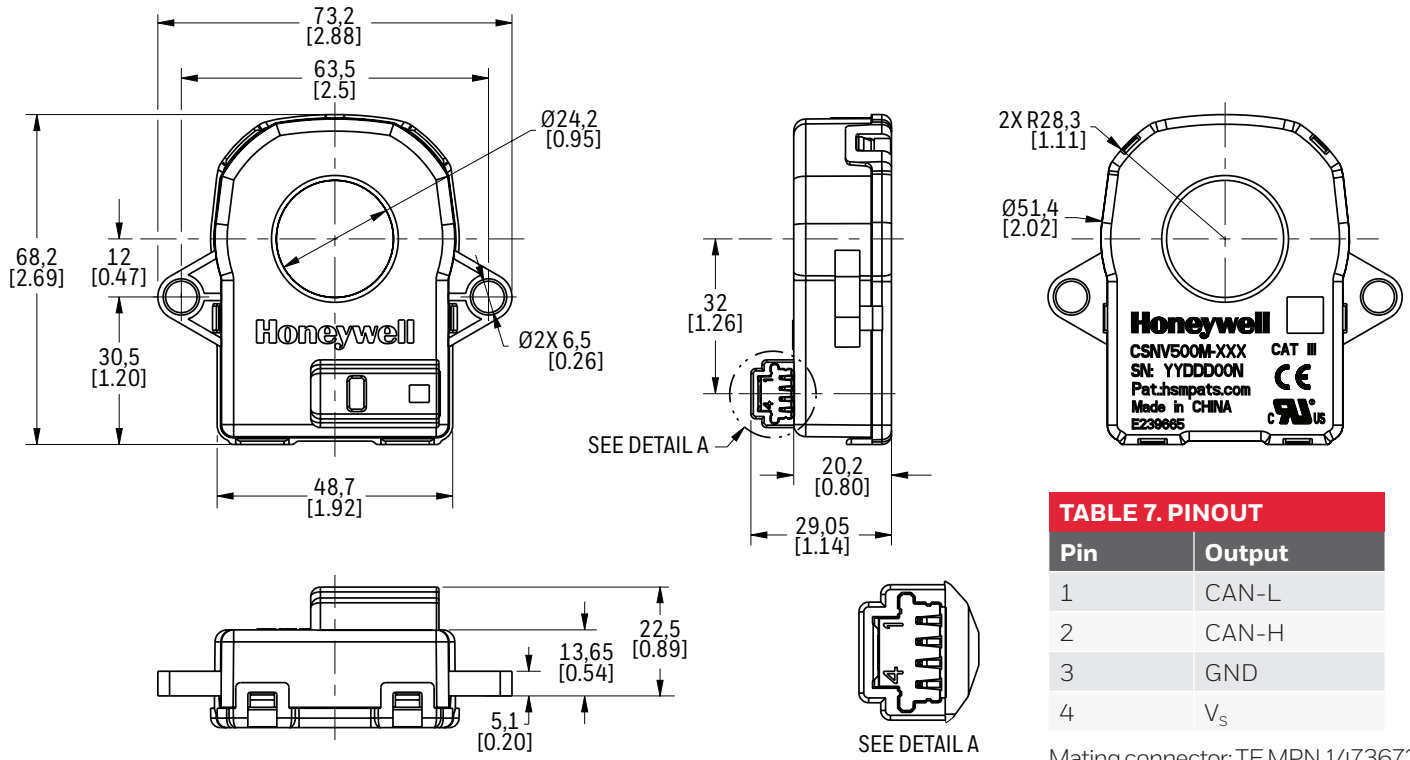

TABLE 7. PINOUT

Pin	Output
1	CAN-L
2	CAN-H
3	GND
4	V <sub>s</sub>

Mating connector: TEMPN 1473672-1

## Mounting type N: Through-hole with metal bushing

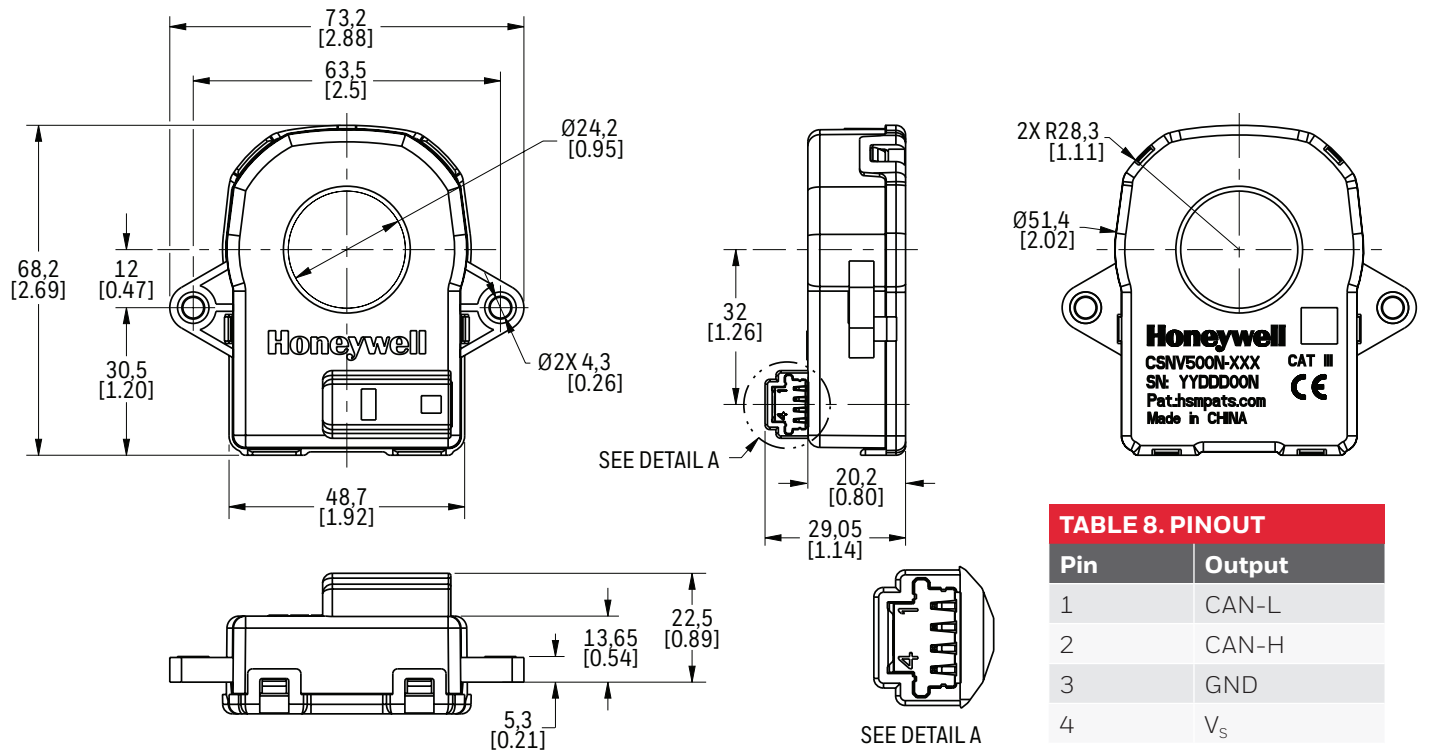

TABLE 8. PINOUT

Pin	Output
1	CAN-L
2	CAN-H
3	GND
4	V <sub>s</sub>

Mating connector: TEMPN 1473672-1

# CLOSED LOOP CURRENT SENSORS

## CSNV500 SERIES

**TABLE 9. EMC TEST SPECIFICATIONS**

Test	Standard	Procedure
CISPR 25 Conducted RF Emissions - Voltage	CISPR25	According to CISPR 25:2008 Commission Form of Testing
CISPR 25 Conducted RF Emissions - Current	CISPR25	According to CISPR 25:2008 Commission Form of Testing
CISPR 25 Radiated Emissions	CISPR25	According to CISPR 25:2008 Commission Form of Testing
Bulk Current Injection (BCI) Test	ISO 11452-4	According to ISO 11452-4
Rf Anti-Interference ALSE Method	ISO 11452-2	According to ISO 11452-2
Transient Disturbances Conducted along Supply Lines	ISO 7637-2	According to ISO 7637-2
Transient Disturbances Conducted along I/O or Sensor Lines	ISO 7637-3	According to ISO 7637-3
Immunity to Magnetic Field	ISO 11452-8	According to ISO 11452-8
Electrostatic Discharge	ISO 10605	Unpowered direct contact discharge: $\pm 4$ kV, $\pm 8$ kV Unpowered air discharge: $\pm 8$ kV, $\pm 15$ kV Powered-up direct contact discharge: $\pm 4$ kV Powered-up air discharge: $\pm 8$ kV
Radio Frequency Electromagnetic Field	IEC 61000-4-3	10 V/m (80 MHz to 1 GHz), 3 V/m (1.4 GHz to 2 GHz), 1 V/m (2.0 GHz to 2.7 GHz)
Fast Transients Bursts Susceptibility Test	IEC 61000-4-4	1 kV Power port, 2 kV CAN signal and control port
Radio Frequency Continuous Conducted	IEC 61000-4-6	0.15 MHz to 80 MHz, 3 V 80% AM (1 kHz)
Radio Frequency Magnetic Field	IEC 61000-4-8	30 A/M
Radiated Disturbance (3M semi-anechoic chamber)	CISPR-11	Group 1, Class A

## CLOSED LOOP CURRENT SENSORS CSNV500 SERIES

**TABLE 10. ENVIRONMENTAL TEST SPECIFICATIONS**

Test	Standard	Procedure
Low Temperature Operating Endurance	ISO16750-4	120 hr at -40°C, power on
High Temperature Operating Endurance	ISO16750-4	85°C, 3000 hr, power on
Powered Thermal Cycle Endurance	ISO16750-4	8 hr at 120 cycles, 960 hours
High Temperature and Humidity Endurance	IEC60068-2-67	85°C, 85% humidity, 1000 hr, power on
Vibration	IEC60068-2-64	5 Hz to 2000 Hz, 20 hr/axis, 3 axis with -40°C/85°C temperature cycle during test. Power on
Mechanical Shock	ISO16750-3	500 m/s, 2,20 each direction (60 total), half sine pulse. Power on
Package Drop	ISTA-1A	With final packaging, drop in direction at 1 corner, 3 edge, 4 face $\geq$ total 9 drops, 1 m on concrete floor
Handling Drop	ISO 16750-3	1st fall of each DUT at a different dimensional axis, 2nd fall with the given DUT at the same dimensional axis but on the opposite side of the housing, from 1 m on concrete floor.
Dust (and other Solid Intrusion)	ISO20653	IP category: 4
Water Intrusion	—	Not tested. IP category: 0. Not protected



# CLOSED LOOP CURRENT SENSORS

## CSNV500 SERIES

**TABLE 11. ELECTRICAL TEST SPECIFICATIONS**

Test	Standard	Procedure
Long Time Overvoltage Test	ISO 16750-2	85°C, power supply at 18 V for 3000 hours
Superimposed Alternating Voltage	ISO 16750-2	25°C. Test voltage $U_c$ max 18 V for 12 V systems; ac voltage (sinusoidal): severity 2, UPP = 4 V
Slow Decrease/ Increase of Supply Voltage	ISO 16750-2-4.5	10 cycles, 25°C. Power supply changes from 18 V to 0 V/ 0 V to 18 V with 0.5 V $\pm$ 0.1 V step. At any step, power supply maintain 1 min.
Slow Decrease Fast Increase of Supply Voltage	ISO 16750-2-4.5	According to ISO 16750-2-4.5 of testing standard and Fig.
Reset Behavior at Voltage Drop	ISO16750-2-4.6.2.2	25°C. See Fig. 6
Momentary Drop in Supply Voltage	ISO 16750-2-4.6.1	25°C. $U_{cmin}$ to 4.5 V. See Fig. 4
Starting Profile	ISO16750-2	According to ISO 16750-2 of testing standard and Fig.
Reverse Voltage Test	ISO16750-2-4.7	25°C, power supply at -24 V for 10 mins
Single line Open Circuit Tests	ISO16750-2-4.9	25°C, connect sensor to 12 V power supply and power on the sensor. Disconnect $U_s$ , GND, CAN-H, and CAN-L in sequence. Each open circuit time: 60 s $\pm$ 1 s
Connector Open Circuit Tests	ISO16750-2	25°C, connect sensor to 12 V power supply and power on the sensor. Disconnect connector. Each open circuit time: 10 s $\pm$ 1s
dc Supply Voltage	ISO16750-2	25°C, $I_p$ = 10 A. Power supply at $U_{cmin}$ 7 V and $U_{cmax}$ 18 V
Insulation Resistance Test	ISO 16750-2-4.12	25°C, 500 Vdc for 60 s; Resistance criteria: > 500 MOhm
Ground Reference and Supply Offset	ISO16750-2-4.8	Offset voltage = 1 V

## NOTICE PRELIMINARY DOCUMENTATION

The information contained in this document is preliminary and for reference only. Preliminary means that the product described has not been or is currently being formally tested. Specifications are subject to change without notice. Reliance on the information contained herein is at the reader's own risk.

### For more information

Honeywell Sensing & Safety Technologies services its customers through a worldwide network of sales offices and distributors. For application assistance, current specifications, pricing or the nearest Authorized Distributor, visit our [website](#) or call:

USA/Canada	+1 302 613 4491
Latin America	+1 305 805 8188
Europe	+44 1344 238258
Japan	+81 (0) 3-6730-7152
Singapore	+65 6355 2828
Greater China	+86 4006396841

### Honeywell Sensing & Safety Technologies

830 East Arapaho Road  
Richardson, TX 75081  
[ww.honeywell.com](http://ww.honeywell.com)

## WARRANTY/REMEDY

Honeywell warrants goods of its manufacture as being free of defective materials and faulty workmanship during the applicable warranty period. Honeywell's standard product warranty applies unless agreed to otherwise by Honeywell in writing; please refer to your order acknowledgment or consult your local sales office for specific warranty details. If warranted goods are returned to Honeywell during the period of coverage, Honeywell will repair or replace, at its option, without charge those items that Honeywell, in its sole discretion, finds defective.

**The foregoing is buyer's sole remedy and is in lieu of all other warranties, expressed or implied, including those of merchantability and fitness for a particular purpose. In no event shall Honeywell be liable for consequential, special, or indirect damages.**

While Honeywell may provide application assistance personally, through our literature and the Honeywell web site, it is buyer's sole responsibility to determine the suitability of the product in the application.

Specifications may change without notice. The information we supply is believed to be accurate and reliable as of this writing. However, Honeywell assumes no responsibility for its use.

## WARNING PERSONAL INJURY

DO NOT USE these products as safety or emergency stop devices or in any other application where failure of the product could result in personal injury.

**Failure to comply with these instructions could result in death or serious injury.**

## WARNING MISUSE OF DOCUMENTATION

- The information presented in this product sheet is for reference only. Do not use this document as a product installation guide.
- Complete installation, operation, and maintenance information is provided in the instructions supplied with each product.

**Failure to comply with these instructions could result in death or serious injury.**