

**SS Series (Wiring System: Central Terminal Box) Wet Type Solenoid Valve** 26.4 to 42 gpm  
5075 psi

### Features

Very long life

The movable iron core of the wet type solenoid is immersed in oil, which keeps it lubricated and cushions it from impact and vibration, ensuring very long life.

Low switching noise

The wet-type solenoid valve provides very low core switching noise, for quiet operation.

High pressure, large capacity, with minimal pressure loss

Comprehensive fluid reaction force

compensation and low pressure compensation construction provide large capacity and low pressure loss.

G01 : 5075 psi (26.4 gpm)

G03 : 5075 psi (42 gpm)

Easy connections

A special wiring box provides a COM port and indicator light as standard for simple wiring and maintenance.

Easy coil replacement

A plug-in type coil enables one-touch coil replacement.

Wide-ranging backward compatibility makes it simple to replace previous valve models with this one. Combining this valve with a modular valve contributes to the compact configuration of the overall device.

Compliant with global and international safety regulations (G01 size CE, UL, CSA, and G03 size UL). Can be used safely around the world. Contact us for models and specifications of compliant products.

### Specifications

Model No.		SS-G01 (D03)				SS-G03 (D05)					
		Standard Type		Shockless Type		Standard Type				Shockless Type	
		Maximum Flow Rate gpm	Maximum Working Pressure psi	Maximum Flow Rate gpm	Maximum Working Pressure psi	AC Solenoid Type		DC Solenoid Type (With built-in rectifier)			
Maximum Flow Rate gpm	Maximum Working Pressure psi					Maximum Flow Rate gpm	Maximum Working Pressure psi	Maximum Flow Rate gpm	Maximum Working Pressure psi		
JIS Symbol	Operation Symbol										
	-A2X-	7.9		7.9		10.5	22.4	22.4			
	-H2X-										
	-E2X-					22.4					
	-A3X-	21									
	-H3X-										
	-E3X-										
	-A3Z-	17.1									
	-H3Z-										
	-E3Z-										
	-A4-	13.2									
	-H4-										
	-A5-	26.4	5075	13.2	3625	34.3	5075	42.2	5075	34.3	3625
	-H5-										
	-C2-										
	-C5-										
	-C9-										
	-C1S-										
	-C6S-										
	-C1-	AC Solenoid 17.1									
	-C6-	DC Solenoid 21.1									
	-C4-	13.2									
	-C7Y-										
	-C8-										

Note: The maximum flow rate of each valve depends on the pressure. For details, see pages D-12 and D-13.

		SS-G01			SS-G03			
		AC Solenoid	DC Solenoid		AC Solenoid	DC Solenoid		
			Built-in Rectifier			Built-in Rectifier		
C*	E*	D*	C*	E*	D*			
Maximum Working Pressure	P, A, B ports		5075 psi					
Maximum Allowable Backpressure	T port		3045 psi		2320 psi			
Switching frequency (cycles/minute)	Standard Type	300	120	300	300	120	240	
	Shockless Type	—		120	—		120	
Standard	Indicator light		R		R			
Option	Shockless	—	F		—	F		
	Surgeless	G	—	G	G	—	G	
	With manual push-button	N					N	
	Quick Return	—	Q	—	—	Q	—	
Weight (kg)	Double Solenoid	1.8	2.0		4.2	5.5		
	Single Solenoid	1.4	1.5		3.5	4.1		
Operating Environment	Dust Resistance/Water Resistance Rank		IP64 (Dust-tight, Splash-proof)					
	Ambient Temperature		-4 to 122°F					
	Operating Fluid	Temperature Range		-4 to 158°F				
		Viscosity Range		15 to 300 centistokes				
		Filtration		10 microns or less				
Mounting bolt	Size × Length		10-24 x 1 3/4 LG (not included)		1/4-20 x 2 3/4			
	Tightening Torque		3.6 to 5 ft lbs		14.7 to 18.4 ft lbs			

Note: 1. Maximum operating pressure depends on the valve type. For details, see page D-1.  
 2. For mounting bolts, use 12T, grade 8 or equivalent.  
 3. Mounting bolts are not included with the O1 size. Bolts are included with the O3 size.

• Handling

- In order to realize the full benefits of the wet type solenoid valve, configure piping so oil is constantly supplied to the T port. Never use a stopper plug in the T port.
- Ensure that surge pressure in excess of the maximum allowable back pressure does not reach the T port.
- Note that the maximum flow rate is limited when used as a four-way valve, or by blocking ports for use as a two-way valve or one-way valve.
- Always keep the operating fluid clean. Allowable contamination is class NAS12 or less.
- When using petroleum type operating fluid, use ISO VG 32, 46.
- For details about using fire-resistant hydraulic fluid, contact your agent.
- Use this valve only within the allowable voltage range.
- Do not allow the AC solenoid to become charged until you install the coil into the valve.
- In the case of operation symbols A2X, H2X, and E2X, run drain piping from the valve T port.
- Maintaining a switching position under high pressure for a long period can cause

abnormal operation due to hydraulic lockup. Contact your agent when you need to maintain a switching position for a long period.  
 11 When using a detent type (E2X, 3X, E3Z), use constant energization in order to securely maintain the switching position.

12 Note that manual pin operating pressure changes in accordance with tank line back pressure.  
 13 The series described in the table below are available for use as RSS and RIS Series solenoid control relief valves.

RSS-***-AR*(H)-** <sup>15</sup> / <sub>23</sub> RIS-***-AR*(H)-** <sup>21</sup>	SS-G01-AR-R-**-31
RSS-***-AQ*(H)-** <sup>15</sup> / <sub>23</sub> RIS-***-AQ*(H)-** <sup>21</sup>	SS-G01-A3X-R-**-31
RSS-***-F(H)-** <sup>15</sup> / <sub>23</sub> RIS-***-F-**- <sup>21</sup>	SS-G01-A8XO-R-**-31 SS-G01-A3X-R-**-31

14 The coil surface temperature increases if this valve is kept continuously energized. Install the valve so there is no chance of it being touched directly by hand.

15 Use the following table for specification when a sub plate is required.

Model No.	Pipe Diameter	Maximum Working Pressure psi	Recommended Flow Rate gpm	Weight lbs	Applicable Valve Type	
MSA-01X-E10	1/4	3625	5.2	1.2	SS-G01-**-R-**-31	
MSA-01Y-E10	3/8		10.4			
MS-03-E30	3/8		11.8	2.3		SS-G03-**-R-**-22
MS-03X-E30	1/2		21.1			

Solenoid Assembly Specifications

Solenoid Type	Power Supply Type	Voltage (V)	Frequency (Hz)	For SS-G01				For SS-G03					
				Solenoid Coil Type	Drive Current (A)	Holding Current (A)	Holding Power (W)	Allowable Voltage Range (V)	Solenoid Coil Type	Drive Current (A)	Holding Current (A)	Holding Power (W)	Allowable Voltage Range (V)
AC	C1	AC100	50	EDC64-C1	2.2	0.52	25	80 to 110	ECB64-C1	5.4	0.92	36.0	80 to 110
			60		2.0	0.38	22			90 to 120	4.6	0.62	
		AC110	60		2.2	0.46	28	5.0			0.78	42.0	90 to 120
	C115	AC110	50	EDC64-C115	2.0	0.47	25	90 to 120	ECB64-C115	5.0	0.85	36.0	90 to 120
			60		1.8	0.35	22			100 to 130	4.2	0.57	
		AC115	60		2.0	0.42	28	4.6			0.72	42.0	100 to 130
	C2	AC200	50	EDC64-C2	1.1	0.26	25	160 to 220	ECB64-C2	2.7	0.46	36.0	160 to 220
			60		1.0	0.19	22			180 to 240	2.3	0.31	
		AC220	60		1.1	0.23	28	2.5			0.39	42.0	180 to 240
	C230	AC220	50	EDC64-C230	1.0	0.24	25	180 to 240	ECB64-C230	2.5	0.42	36.0	180 to 240
			60		0.91	0.17	22			200 to 260	2.1	0.29	
		AC230	60		1.0	0.21	28	2.3			0.36	42.0	200 to 260
DC with Built-in Rectifier	E1	AC100	50/60	EDC64-E1-1A	0.31		27	90 to 110	ECB64-E1	0.40		34.0	90 to 110
	E115	AC110	50/60	EDC64-E115-1A	0.26		25	100 to 125	ECB64-E115	0.33		31.0	100 to 125
		AC115			0.27		27			0.34		34.0	
	E2	AC200	50/60	EDC64-E2-1A	0.15		26	180 to 220	ECB64-E2	0.22		37.0	180 to 220
	E230	AC220	50/60	EDC64-E230-1A	0.12		24	200 to 250	ECB64-E230	0.16		30.0	200 to 250
AC230		0.13			27	0.17				33.0			
DC	D1	DC12	☒	EDC64-D1-1A	2.2		26	10.8 to 13.2	ECB64-D1	2.6		31.0	10.8 to 13.2
	D2	DC24	☒	EDC64-D2-1A	1.1		26	21.6 to 26.4	ECB64-D2	1.5		36.0	21.6 to 26.4

Understanding Model Numbers

SS - G 03 - A 3 X - \* R - C2 - E22

Design number  
E31: 01 size; 10 - 24 mounting bolt  
E22: 03 size; 1/4 - 20 mounting bolt

Power supply  
C: AC (50/60Hz)  
D: DC  
E: AC (Built-in rectifier; 50/60Hz)

C1=AC100V C115=AC110V C2=AC200V C230=AC220V  
D1=DC12V D2=DC24V  
E1=AC100V E115=AC115V E2=AC200V E230=AC230V

With indicator light

Auxiliary symbol (Can be combined in alphabetic sequence.)  
F: Shockless type (Available with power supply D\*, E)  
G: Surgeless type (Available with power supply C\*, D\*)  
N: With manual push-button  
Q: Quick return type (Available with power supply E\*)

Transition Flow Path (Specify for A2X, H2X, E2X, A3X, H3X, E3X, A3Z, H3Z, E3Z, C7Y only.)

X	Y	Z
Closed	Semi-open	Open

Center position

0	1	2	3	4	5
6	7	8	9	1S	6S

Note 1: P=Pressure port; A and B=Connection port to cylinder, etc.; T=Connection port to tank

Operation Method

A	H	C	E
Spring Offset	Spring Center	Spring Center	Detent

Nominal diameter  
01 size (D03)  
03 size (D05)

Mounting method  
G: Cascade mounting

Wet type solenoid operated directional control valve

# Options

## (Auxiliary Symbol Explanations)

### Shockless Type (Auxiliary Symbol: F)

#### Switching Response Characteristics

The pressure waveforms for each valve in the hydraulic circuit shown below are shown at the bottom of this block.

Opening and closing of a dry type valve generates shock (noise) and pipe vibration due to the sudden drop or rise in pressure. With a shockless solenoid valve, pressure fluctuation when the valve is opened or closed is smoothed, which eliminates shock (noise) and pipe vibration.

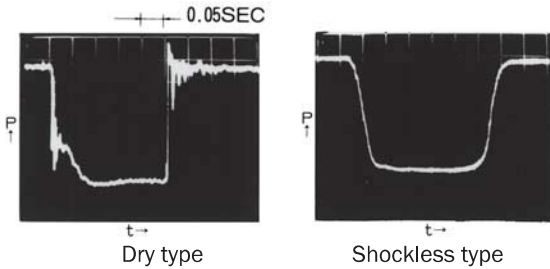
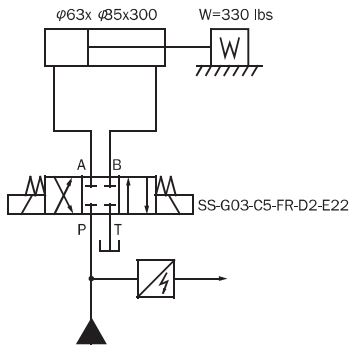

### Surgeless Type (Auxiliary Symbol: G)

The surge pressure waveforms when the DC solenoid valve power supply is opened and closed by a relay are shown at the bottom of this block. A built-in surge absorber element eliminates sparking and surge pressure.

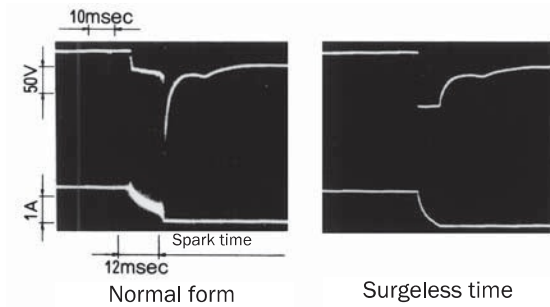
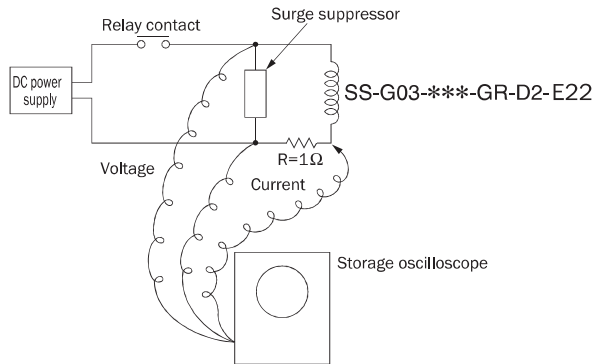

### Manual Button Type (Auxiliary Symbol: N)

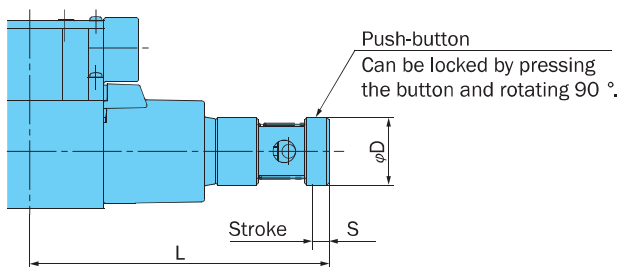

Part No.		L	S	D
EDB14-D-1A	AC Solenoid	133.5	7.5	30
EDB14-A	DC Solenoid	140.5		
ECB14-A	AC Solenoid	155.5	9.5	35
ECB14-D	DC Solenoid	173.5		

### Quick Return (Auxiliary Symbol: Q)

- Handling
1. This type is used in the case of power supply type E\* (with built-in rectifier) to shorten the spring return time. This also applies to D\*.
  2. Quick return device is built-in to central terminal box.

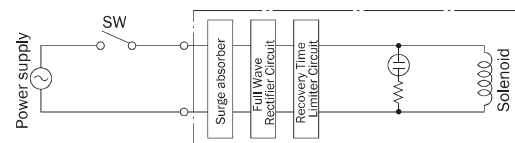

# Installation Dimension Drawings

AC Solenoid  
 SS-G01-A\*\*-R-C\*-31  
 SS-G01-H\*\*-R-C\*-31

Note)  
 SS-G01-H\*\*-R\*\*-31  
 The solenoid is on the opposite side of that shown for SOLa in the illustrations shown here.

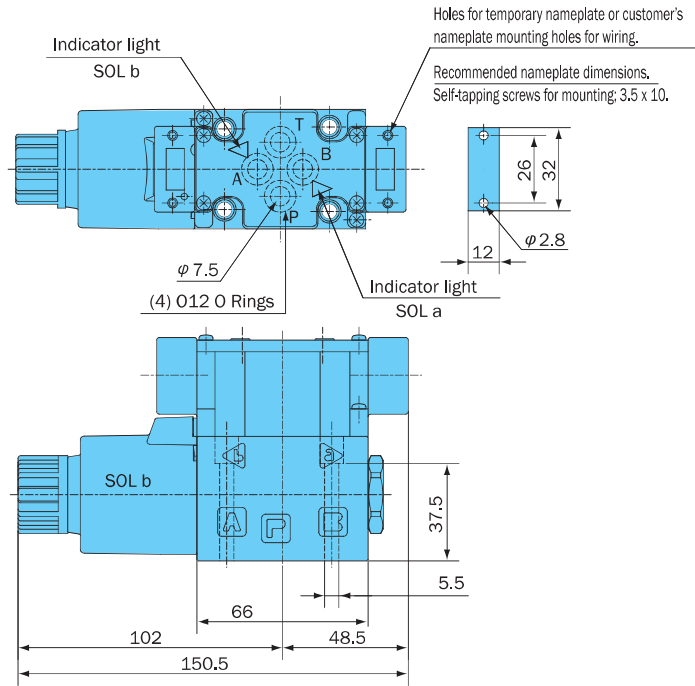
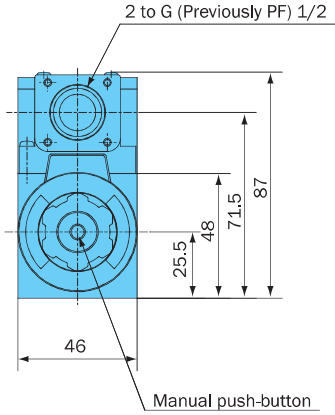

SS-G01-C \*\*-R-C\*-31  
 SS-G01-E \*\*-R-C\*-31

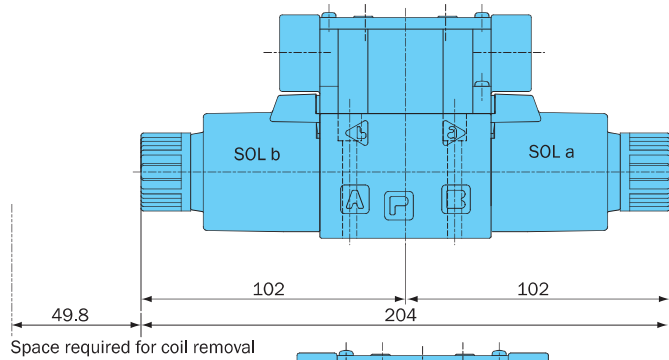

DDC Solenoid and Rectifier  
 SS-G01-A \*\*-R-D/E\*-31  
 SS-G01-H \*\*-R-D/E\*-31  
 SS-G01-C \*\*-R-D/E\*-31  
 SS-G01-E \*\*-R-D/E\*-31

For sub plate SS-G01

Model No.	E	Weight lbs
MSA-01X-E10	1/4	2.6
MSA-01Y-E10	3/8	2.6

Gasket Surface Dimensions  
 ( ISO 4401-03-02-0-94  
 ( JIS B 8355 D-03-02-0-94 ) )

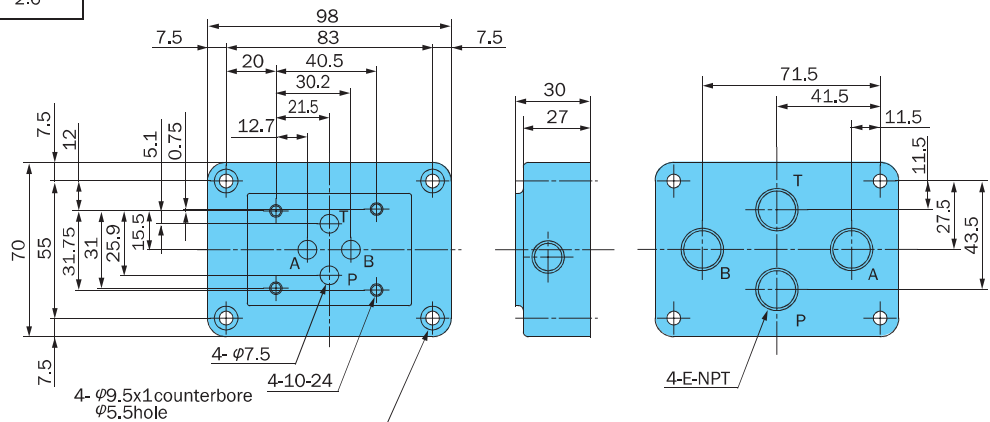

# Installation Dimension Drawings

AC Solenoid  
 SS-G03-A\*\*-R-C\*-E22  
 SS-G03-H\*\*-R-C\*-E22

Note:  
 SS-G03-H\*\*-R\*\*-E22  
 The solenoid is on the opposite side of that shown for SOLa in the illustrations shown here.

	SS-G03-**-R**-J22	SS-G03-**-R**-22
$\phi D$	$\phi 6.8$	$\phi 8.5$
L	60.5	58

SS-G03-C\*\*-R-C\*-E22  
 SS-G03-E\*\*-R-C\*-E22

DC Solenoid and Rectifier  
 SS-G03-A \*\*-R-D\*/E\*-E22  
 SS-G03-H \*\*-R-D\*/E\*-E22  
 SS-G03-C \*\*-R-D\*/E\*-E22  
 SS-G03-E \*\*-R-D\*/E\*-E22

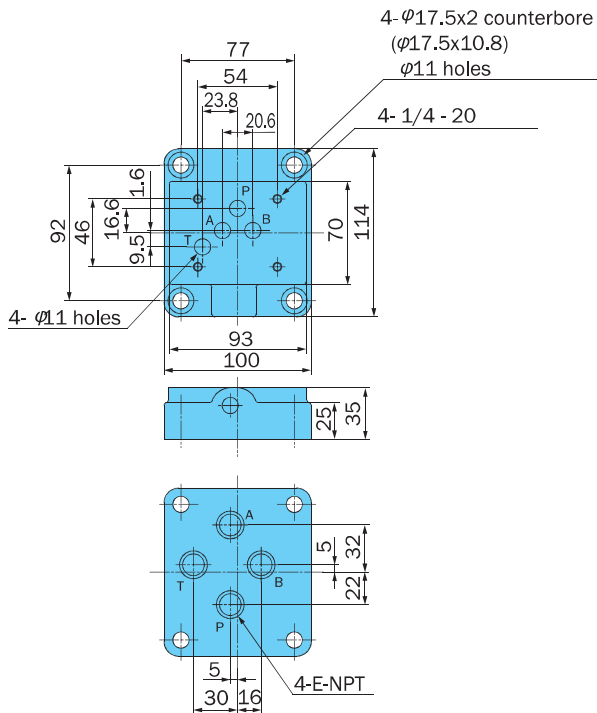
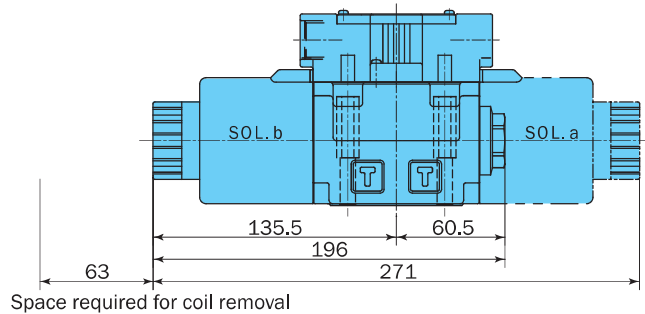
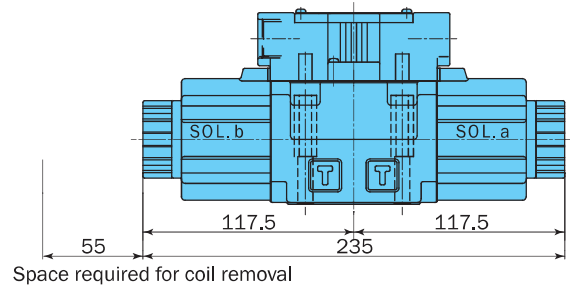
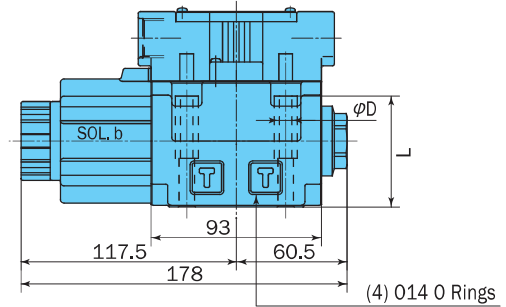
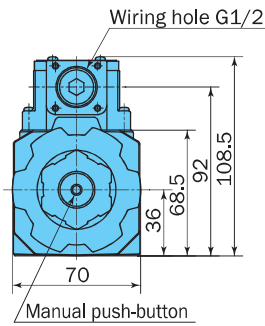
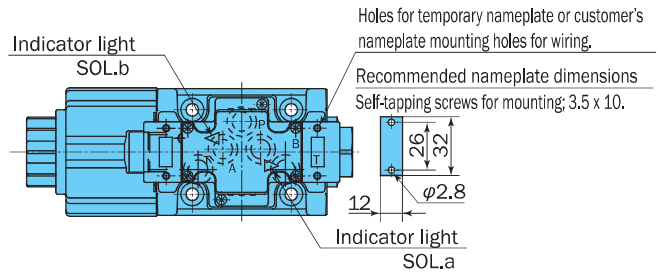

For sub plate SS-G03

Mounting bolt	Model No.	E	Weight lbs
1/4 - 20 x 2 3/4	MSA-03-E10	3/8	5.0
	MSA-03X-E10	1/2	

Gasket surface dimensions  
 ( ISO 4401-05-04-0-94  
 JIS B 8355 D-05-04-0-94 )

Wiring Diagram

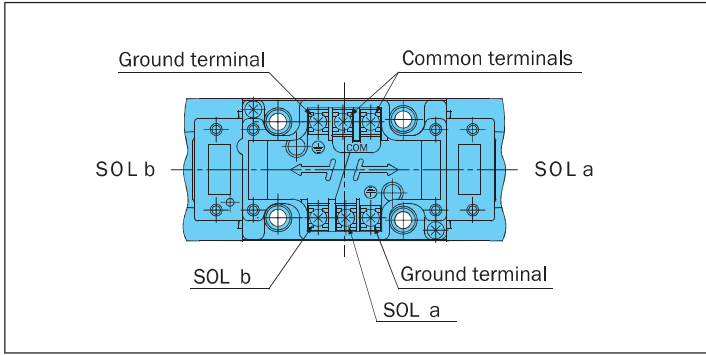

Note:

1. In the case of a double solenoid valve, a common terminal is provided to simplify wiring. When the common terminal is not used, remove the terminal screws.
2. Use the ground terminal when grounding is required.
3. In the case of a solderless terminal, M3 screws.
4. Tighten terminal screws to a torque of 3.6 to 5 ft lbs.

Electrical Circuit Diagram

Type	Model No.	Electrical Circuit
AC Solenoid	SS- G01-***-R-C*- 31 G03-***-R-C*- 22	
AC Solenoid Surgeless Type	SS- G01-***-GR-C*- 31 G03-***-GR-C*- 22	
Built-in Rectifier	SS- G01-***-R-E*- 31 G03-***-R-E*- 22	
DC Solenoid	SS- G01-***-R-D*- 31 G03-***-R-D*- 22	
DC Solenoid Surgeless Type	SS- G01-***-GR-D*- 31 G03-***-GR-D*- 22	
Built-in Rectifier Quick Return Type	SS- G01-***-QR-E*- 31 G03-***-QR-E*- 22	See page D-7 for more information.

# Performance Curves

Hydraulic Operating Fluid Viscosity 32 centistokes

## Pressure Loss Characteristics

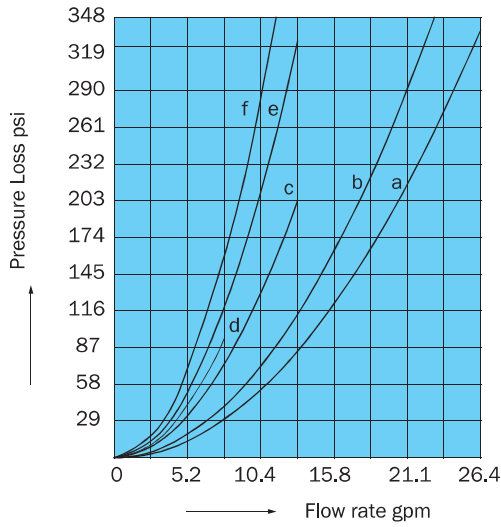

Pump Type	Flow Path	P/ A	P/ B	A/ T	B/ T	P/ T
SS-G01	A2X, H2X, E2X	d	d	—	—	—
	A3X, H3X	b	b	b	b	—
	E3X	b	b	b	b	—
	A3Z, H3Z, E3Z	a	a	a	a	—
	A4, H4, C4	a	a	a	a	a
	A5, H5, C5, C6S	b	b	b	b	—
	C1, C1S	b	b	a	b	—
	C2	a	b	b	b	—
	C6	b	b	a	a	—
	C7Y	f	f	e	e	c
	C8	a	f	b	e	c
C9	a	a	b	b	—	

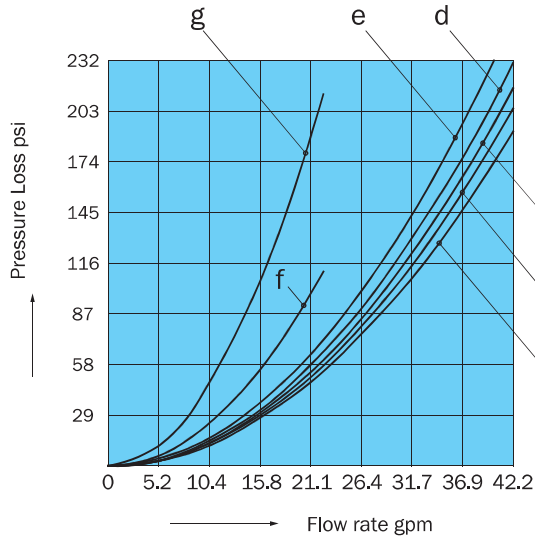

Pump Type	Flow Path	P/ A	P/ B	A/ T	B/ T	P/ T
SS-G03	A2X, H2X, E2X	e	e	—	—	—
	A5	—	c	c	—	—
	H5	c	—	—	c	—
	A3X, H3X, E3X	c	c	d	d	—
	A3Z, H3Z	a	a	d	d	—
	E3Z	b	b	a	a	—
	C1	c	c	a	c	—
	C2	a	c	c	c	—
	A4, H4, C4	a	a	a	a	a
	C5, C1S, C6S	c	c	c	c	—
	C6	c	c	a	a	—
	C7Y	g	g	g	g	f
	C8	a	g	a	g	f
C9	a	a	c	c	—	

## Switching Response Time

Model No.	Response Time (sec)		Measurement Conditions
	Solenoid ON	Spring Return	
SS-G01-**-R-C*-E31	0.02 to 0.03	0.02 to 0.03	2030 psi 7.9 gpm
SS-G01-**-(G)R-D*-E31	0.03 to 0.04	0.02 to 0.04	
SS-G01-**-R-E*-E31	0.03 to 0.04	0.07 to 0.10	
SS-G01-**-F(G)R-D*-E31	0.07 to 0.10	0.04 to 0.07	
SS-G01-**-FR-E*-E31	0.07 to 0.10	0.10 to 0.15	
SS-G03-**-R-C*-E22	0.02 to 0.03	0.02 to 0.03	2030 psi 18.4 gpm
SS-G03-**-(G)R-D*-E22	0.06 to 0.09	0.03 to 0.05	
SS-G03-**-R-E*-E22	0.07 to 0.10	0.10 to 0.15	
SS-G03-**-F(G)R-D*-E22	0.13 to 0.15	0.08 to 0.15	
SS-G03-**-FR-E*-E22	0.10 to 0.15	0.15 to 0.20	

Note: 1. The switching response time changes slightly with operating conditions (pressure, flow rate, viscosity, etc.)  
 2. In the case of power supply type E\* (with built-in rectifier), the spring return time using Quick Return (option symbol: Q) is the same as D\*.



Pressure – Flow Volume Allowable Value

Size	Standard Form, with AC, DC solenoid		
	SS-G01-**-R**-31		
Operation Example Operation Symbol			
A2X, H2X	-	K	K
E2X	-	J	J
A3X, H3X	B	K	K
E3X	A	J	J
A3Z, H3Z	D	D	D
E3Z	D	D	D
A5	A	-	I
H5	A	I	-
C1, C6	Note1) C(E)	I	I
C1S, C5, C6S	A	I	I
C2, C9	A	K	K
A4	F	F	F
H4	F	F	F
C4	F	F	F
C7Y, C8	Note2) G(H)	K	K

Note: 1. Letter in parentheses is for AC solenoid.  
 2. Letter in parentheses is for solenoid with built-in rectifier (E\*), but without Quick Return, and for DC solenoid (D\*) with surge voltage absorbing diode on the electrical circuit.

Size	Shockless Type, with DC solenoid		
	SS-G01-**-FR**-31		
Operation Example Operation Symbol			
A2X, H2X	-	P	P
E2X	-	O	O
A3X, H3X	L	P	P
E3X	L	O	O
A3Z, H3Z	L	L	L
E3Z	L	L	L
A5	L	-	P
H5	L	P	-
C1, C6	M	P	P
C1S, C2, C5, C6S, C9	L	P	P
A4, H4	L	L	L
C4	L	L	L
C7Y, C8	N	P	P

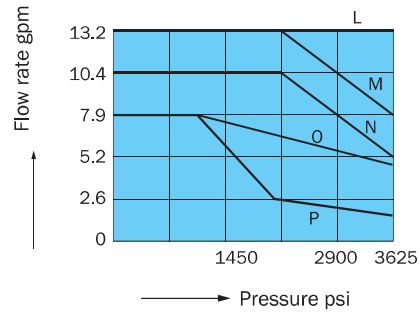
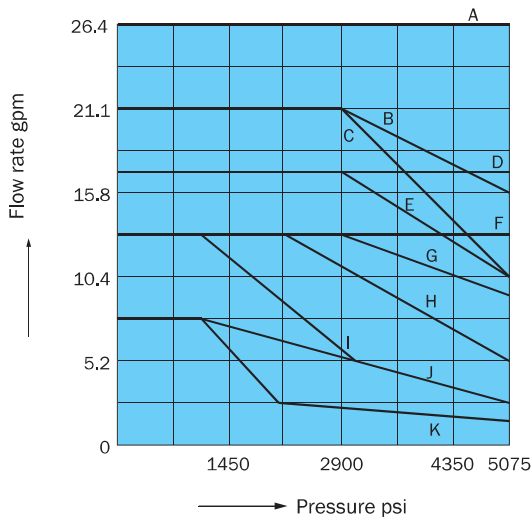

Pressure – Flow Volume Allowable Value

Model No.	Standard Form, with AC Solenoid			Standard Form, with DC Solenoid		
		SS-G03-**-R-C*-E22			SS-G03-**-R-**-E22	
Operation Example						
Operation Symbol						
A2X	—	F	E	☒	G	H
H2X	—	E	F	☒	H	G
E2X	—	C	C	☒	D	D
A3X	A	E	E	A	F	H
H3X	A	E	E	A	H	F
A3Z	A	A	C	A	D	D
H3Z	A	C	A	A	D	D
E3X, E3Z	A	C	C	A	D	D
A5	A	—	D	A	—	G
H5	A	D	—	A	G	—
C1S, C5, C6S	A	D	D	A	G	G
C1, C6	A	D	D	B	G	G
C2	A	G	D	A	I	G
A4, H4, C4	A	A	A	A	A	A
C9	A	G	G	A	I	I
C7Y, C8	B	B	B	Note1) C(E)	C(E)	C(E)
Model No.	Shockless Type, with DC solenoid					
	SS-G03-**-FR-**-E22					
Operation Example						
Operation Symbol						
A2X	—	E	F			
H2X	—	F	E			
E2X	—	C	C			
A3X	A	D	F			
H3X	A	F	D			
A3Z	A	C	C			
H3Z	A	C	C			
E3X, E3Z	A	C	C			
A5	A	—	E			
H5	A	E	—			
C1, C1S, C5, C6, C6S	A	E	E			
C2	A	G	E			
A4, H4, C4	A	A	A			
C9	A	G	G			
C7Y, C8	Note1) B(H)	B(H)	B(H)			
				<p>Note:</p> <ol style="list-style-type: none"> <li>Letter in parentheses is for solenoid with built-in rectifier (E*), but without Quick Return, and for DC solenoid (D*) with surge voltage absorbing diode on the electrical circuit.</li> <li>There is no shockless type for the AC solenoid (C*), so use a solenoid with built-in rectifier (E*) when shockless operation is required with an AC power supply.</li> <li>The maximum flow rate is the allowable value of each port.</li> </ol>		

# Cross-sectional Drawing

SS-G01-A\*\*-R-C\*-31

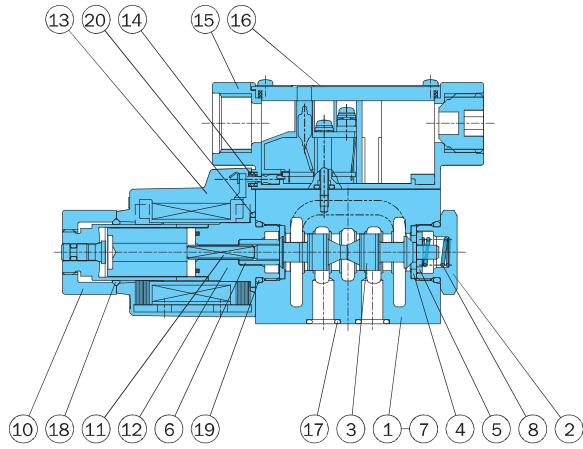

SS-G01-C\*\*-R-C\*-31

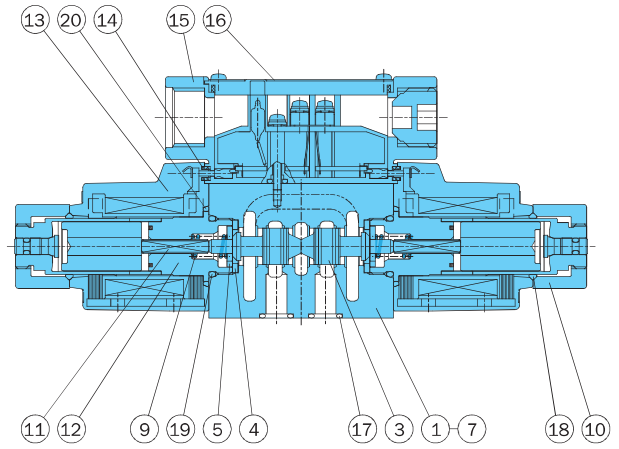

SS-G01-A\*\*-R-D/E\*-31

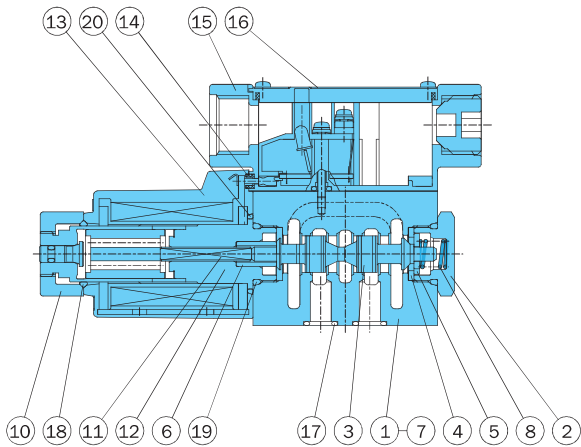

SS-G01-C\*\*-R-D/E\*-31

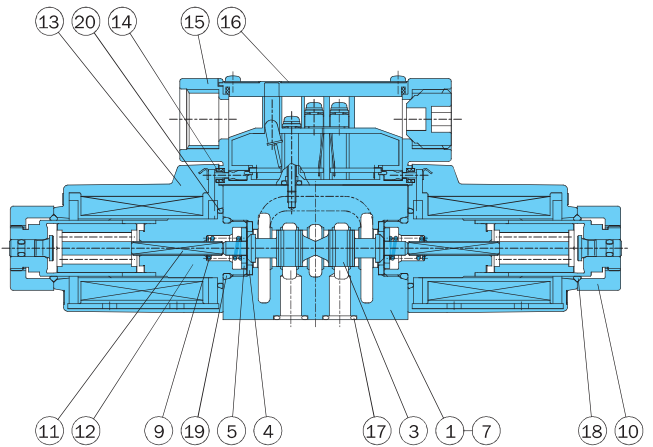

## List of Sealing Parts

Part No.	Part Name	Part Number	Q'ty	
			Single Solenoid	Double Solenoid
17	O-ring	AS568-012(Hs90)	4	4
18	O-ring	1A-P20	1	2
19	O-ring	1B-P18	2	2
20	O-ring	S-25	1	2

Note: 1A and 1B are JIS Standard B 2401, while AS568 is SAE standard.

## Seal Kit Number

Single Solenoid	Double Solenoid
EDCS-A	EDCS-C

Part No.	Part Name	Part No.	Part Name
1	Body	11	Rod
2	Plug	12	Solenoid guide
3	Spool	13	Solenoid coil
4	Retainer A	14	Packing
5	Retainer B	15	Terminal box kit
6	Retainer C	16	Nameplate
7	Spacer	17	O-ring
8	Spring A	18	O-ring
9	Spring C	19	O-ring
10	Nut	20	O-ring

# Cross-sectional Drawing

SS-G03-A\*\*-R-C\*-E22

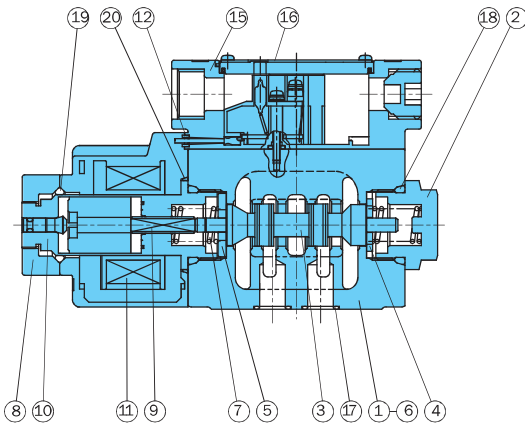

SS-G03-C\*\*-R-C\*-E22

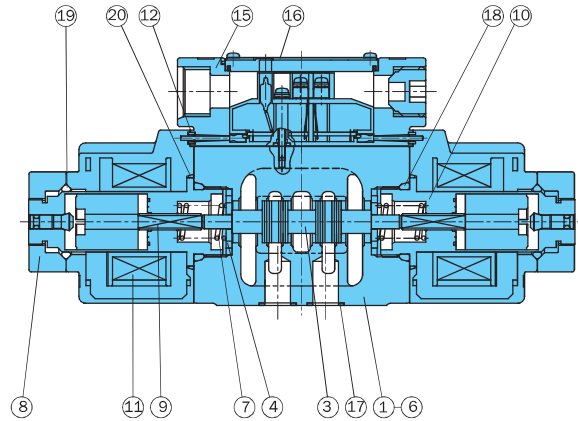

SS-G03-A\*\*-R-D/E\*-E22

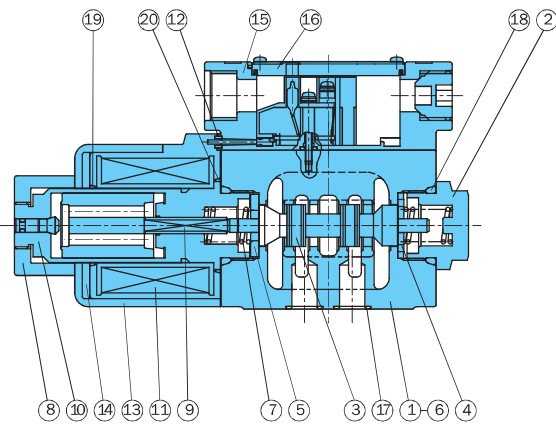

SS-G03-C\*\*-R-D/E\*-E22

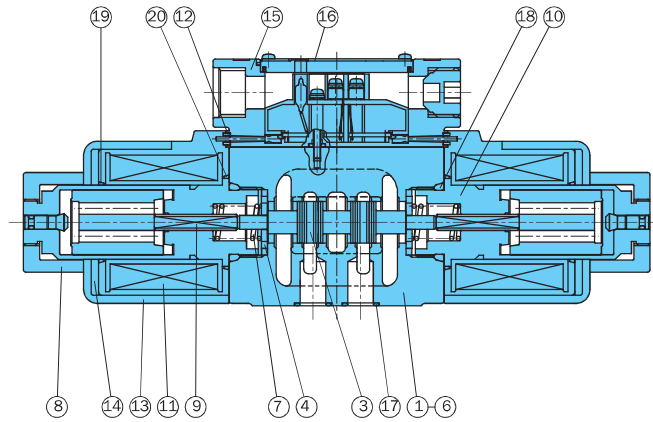

## List of Sealing Parts

Part No.	Part Name	Type/Part Number		Q'ty	
		AC SOL.	DC SOL.	Single Solenoid	Double Solenoid
17	O-ring	AS568-014(Hs90)		5	5
18	O-ring	1B-P28		2	2
19	O-ring	1A-P26	AS568-026	1	2
20	O-ring	AS568-029		2	2

Note: 1A and 1B\*\* indicate JIS Standard B 2401-1A/1B-\*\*.

## Seal Kit Number

AC SOL.		DC SOL.	
Single Solenoid	Double Solenoid	Single Solenoid	Double Solenoid
ECBS-AA	ECBS-CA	ECBS-AD	ECBS-CD

Part No.	Part Name	Part No.	Part Name
1	Body	14	Coil yoke
2	Plug	15	Terminal box kit
3	Spool	16	Nameplate
4	Retainer	17	O-ring
5	Retainer B	18	O-ring
6	Spacer	19	O-ring
7	Spring	20	O-ring
8	Nut		
9	Rod		
10	Solenoid guide		
11	Solenoid coil		
12	Packing B		
13	Coil case		

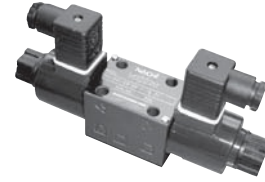

**SA Series (Wiring System: DIN Connector Type) Wet Type Solenoid Valve** 26.4 to 42 gpm  
5075 psi

### Features

**Very long life**  
The movable iron core of the wet type solenoid is immersed in oil, which keeps it lubricated and cushions it from impact and vibration, ensuring very long life.

**Low switching noise**  
The wet-type solenoid valve provides very low core switching noise, for quiet operation.

**Shockless**  
A switching speed adjustment mechanism enables direct, shockless operation (Option F).

**No surge voltage**  
Sparking and surge voltage during solenoid switching is canceled for stable switching (Option G).

**Easy coil replacement**  
A DIN connector type coil enables one-touch coil replacement.

**Wide-ranging backward compatibility**  
makes it simple to replace previous valve models with this one. Combining this valve with a modular valve contributes to the compact configuration of the overall device.

**Global support (G01 size)**  
Meets overseas safety standards (CE, UL, and CSA). It can be safely used anywhere in the world. Contact your agent for certified products.

### Specifications

Model No.		SA-G01 (D03)				SA-G03 (D05)					
		Standard Type		Shockless Type		Standard Type				Shockless Type	
		JIS Symbol	Operation Symbol	Maximum Flow Rate gpm	Maximum Working Pressure psi	Maximum Flow Rate gpm	Maximum Working Pressure psi	AC Solenoid Type		DC Solenoid Type (With built-in rectifier)	
Maximum Flow Rate gpm	Maximum Working Pressure psi							Maximum Flow Rate gpm	Maximum Working Pressure psi		
	-A2X-	7.9	5075	7.9	3625	10.5	5075	22.4	5075	22.4	3625
	-H2X-										
	-E2X-	21.1	5075	7.9	3625	22.4	5075	22.4	5075	22.4	3625
	-A3X-										
	-H3X-	26.4	5075	7.9	3625	22.4	5075	22.4	5075	22.4	3625
	-E3X-										
	-A3Z-	17.1	5075	7.9	3625	22.4	5075	22.4	5075	22.4	3625
	-H3Z-										
	-E3Z-	13.2	5075	7.9	3625	22.4	5075	22.4	5075	22.4	3625
	-A4-										
	-H4-	26.4	5075	7.9	3625	22.4	5075	22.4	5075	22.4	3625
	-A5-										
	-H5-	26.4	5075	7.9	3625	22.4	5075	22.4	5075	22.4	3625
	-C2-										
	-C5-	17.1	5075	7.9	3625	22.4	5075	22.4	5075	22.4	3625
	-C9-										
	-C1S-	13.2	5075	7.9	3625	22.4	5075	22.4	5075	22.4	3625
	-C6S-										
	-C1-	AC Solenoid	5075	7.9	3625	22.4	5075	22.4	5075	22.4	3625
	-C6-	DC Solenoid									
	-C4-	13.2	5075	7.9	3625	22.4	5075	22.4	5075	22.4	3625
	-C7Y-										
	-C8-	10.5	5075	10.5	3625	18.4	3625	26.4	3625	22.4	3625