

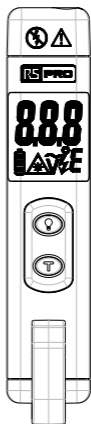

Instruction Manual

IT-1

Infrared Thermometer



SECTION 1 – SAFETY INFORMATION

Safety Information

Understand and follow operating instructions carefully.

Use the tester only as specified in these instructions otherwise, the protection provided by the tester may be impaired.

- To ensure safe operation and service of the tester, follow these instructions.
- Failure to observe warnings can result in severe injury.
- Do not stare into the laser beam.
- Do not point the laser directly at the eye or indirectly off a reflective surface.
- The Volt Sense function must only used to test on insulated wires.
- When testing high voltage wires, keep the tester a minimum of 20mm away from the wire.
- Do not use to sense wire voltages higher than 600V.











European Region Label



US Region Label

Note: Please fit the correct warning label appropriate to the region where the tester is being used

Symbols as marked on the tester and instruction manual

	Battery
	See instruction card
	Do not apply directly to or around bare HAZARDOUS LIVE conductors
	AC measurement
	Conforms to EU directives
	Dispose of in accordance with local regulations.
	Laser light, do not stare into the beam
	Caution ! Non-contact voltage

CE certification

This tester is certified to the following standards :

EN 61326-1 Electromagnetic Emissions and Susceptibility

EN 61010-1 General Safety

EN 60825-1 Laser Safety

Tester Description

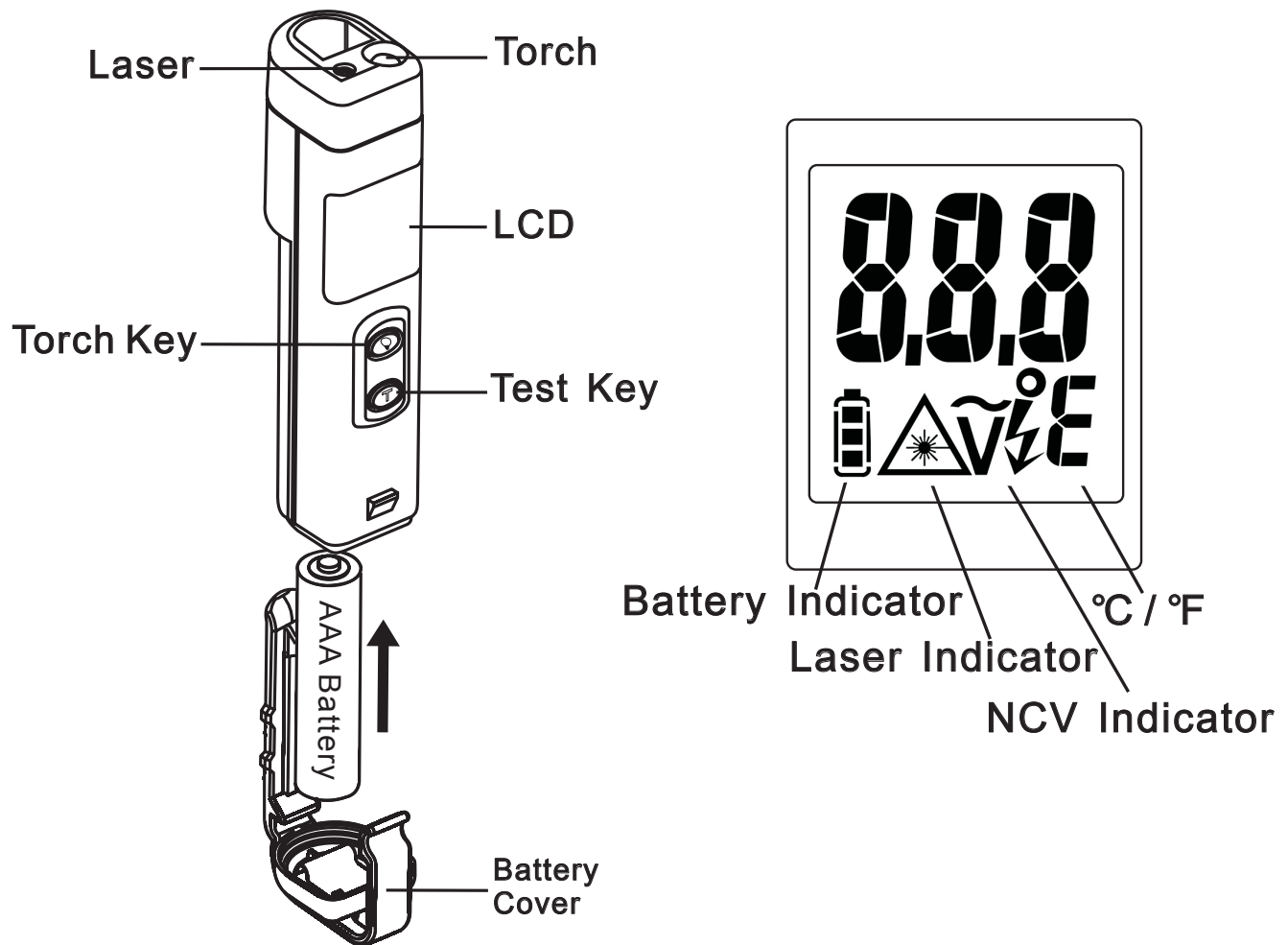

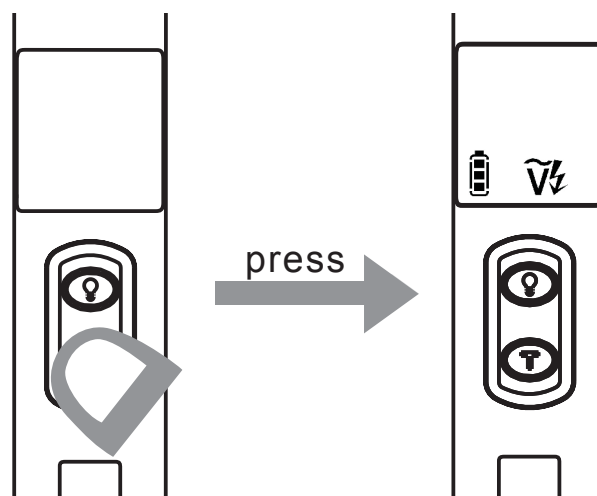

Operating Instructions

Power On / Off



Press the  key until the display activates
Auto Power Off : 3 minutes.

Temperature Measurement

When powered on, press the  key, the tester will show the temperature of the measured target. Then release the  key, the LCD will hold the reading for 10 seconds.

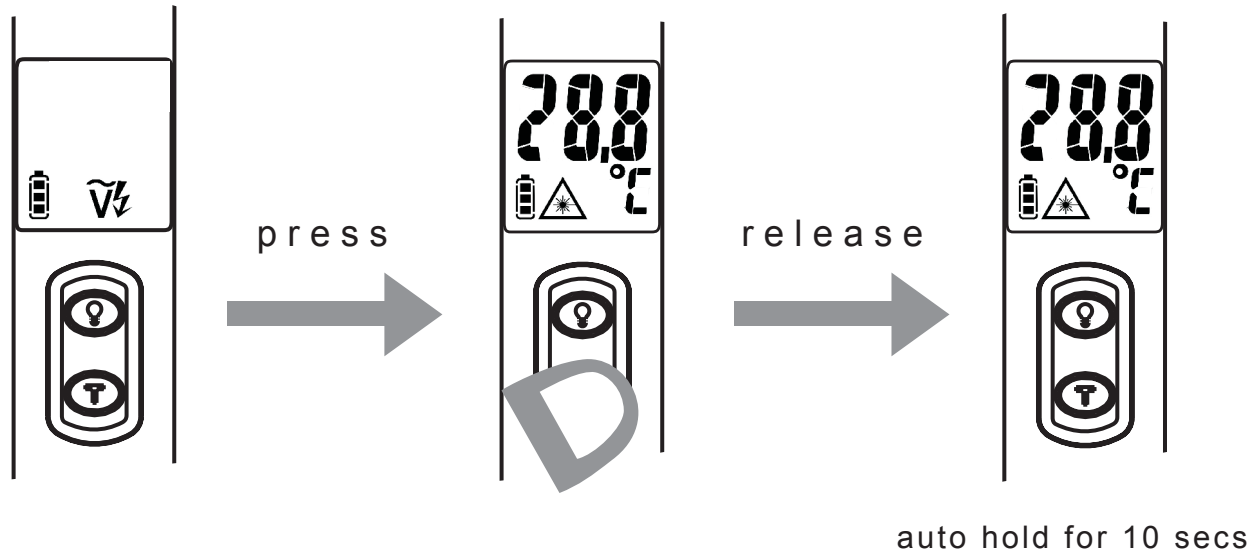

 The laser light points out the measuring direction during the temperature test. Take care, do not stare into the beam



Continuous Measurement Mode

When powered on, press the  key for 3 seconds, the tester will enter the IR temperature continuous measurement mode.

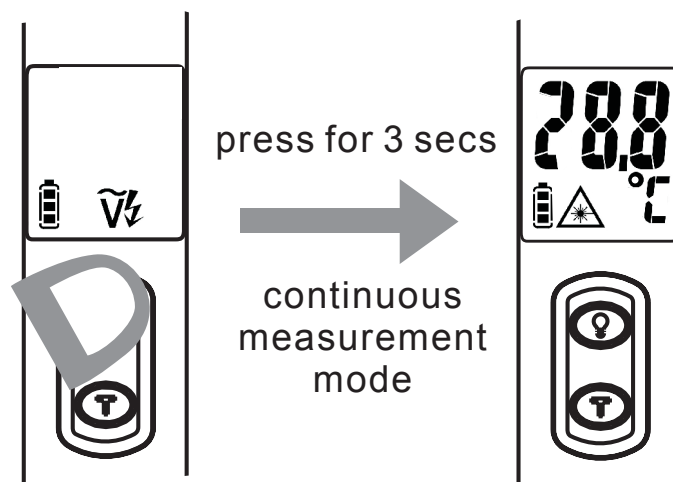
 The laser light points out the measuring direction during the temperature test. Take care, do not stare into the beam.



°C / °F Selection

Press the  key and the  key for 2 seconds at the same time to switch the temperature tester between °C and °F

Notes on making Temperature Measurements

For accurate temperature measurements, allow the tester to acclimatize to the ambient temperature for 30 minutes.

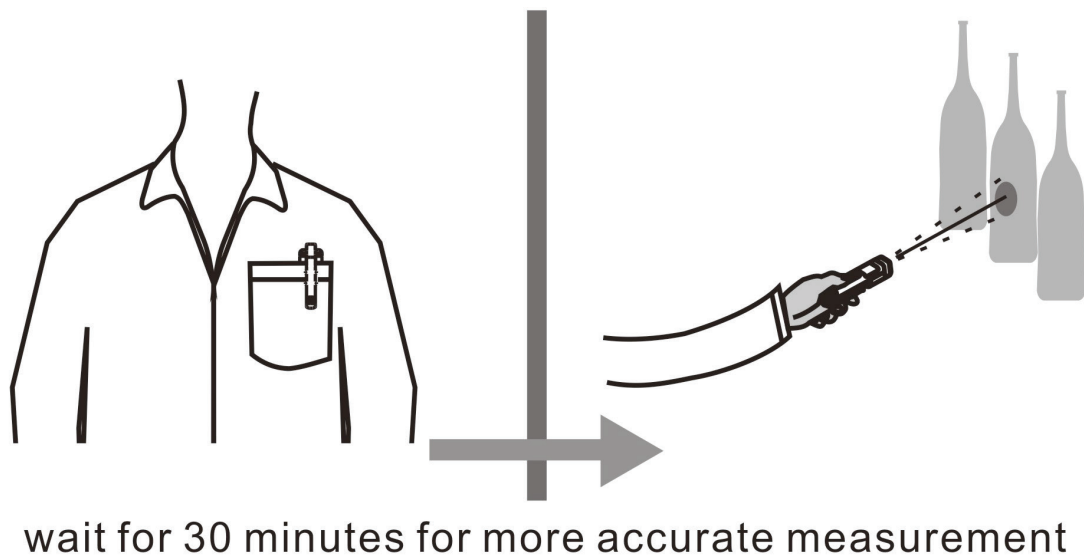
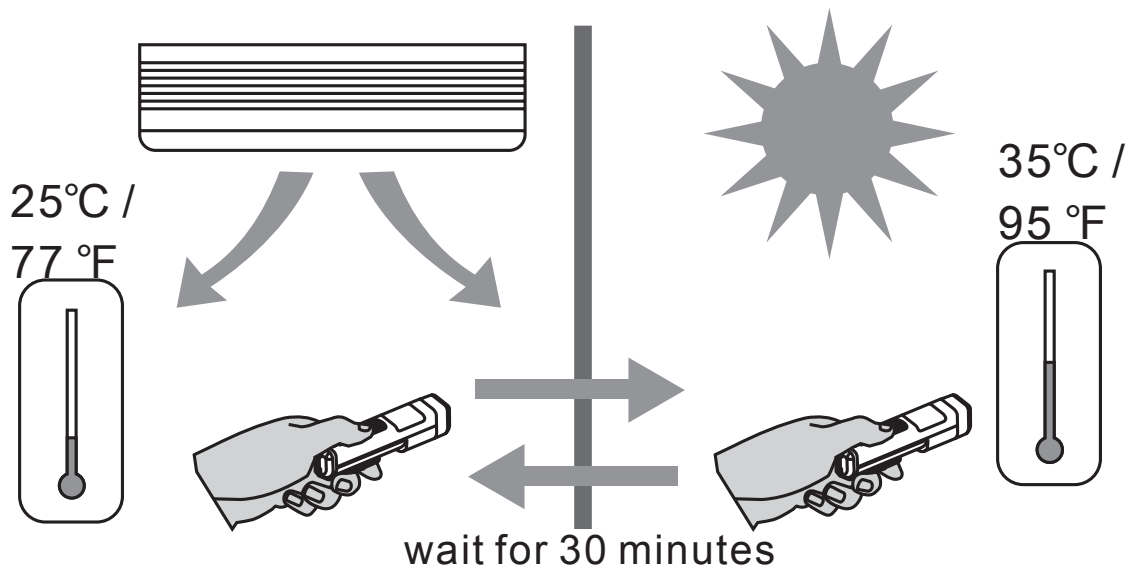

IT-1 Infrared Thermometer English

To prevent thermal effects interfering with the measurement accuracy:

Do not put the fingers on the housing for long periods of time

- Do not cross the “B” line:

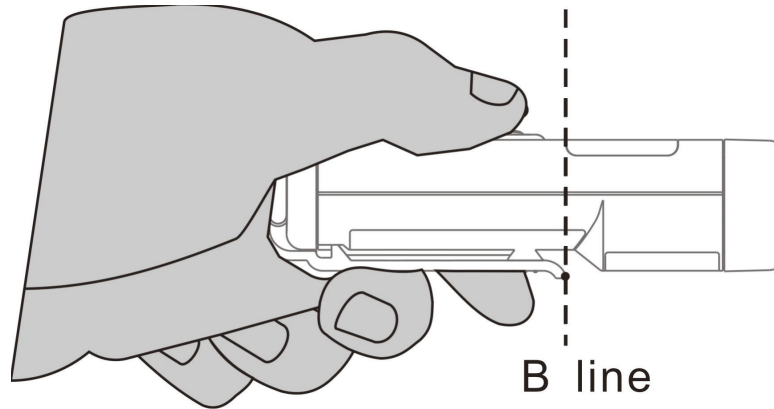

The tester cannot measure through transparent materials such as glass; remove the barrier between the tester and the target surface.

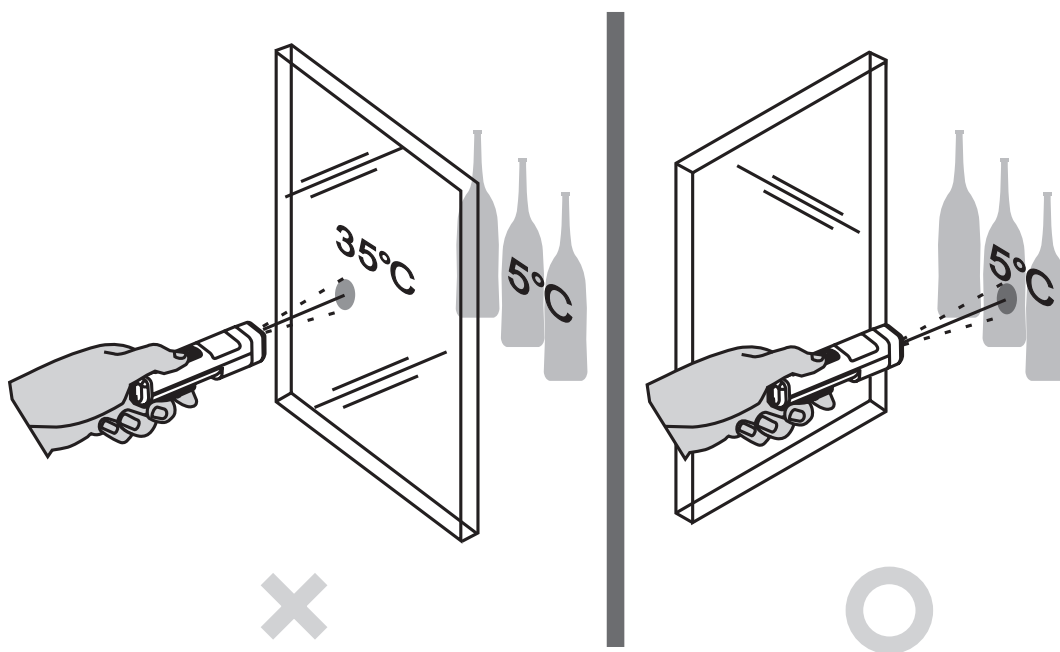

The tester is calibrated at 30 cm; use the tester at about 30cm from the target to get the most accurate measurement.

At longer distances, the target area should be larger than the distance divided by 8.

IT-1 Infrared Thermometer English

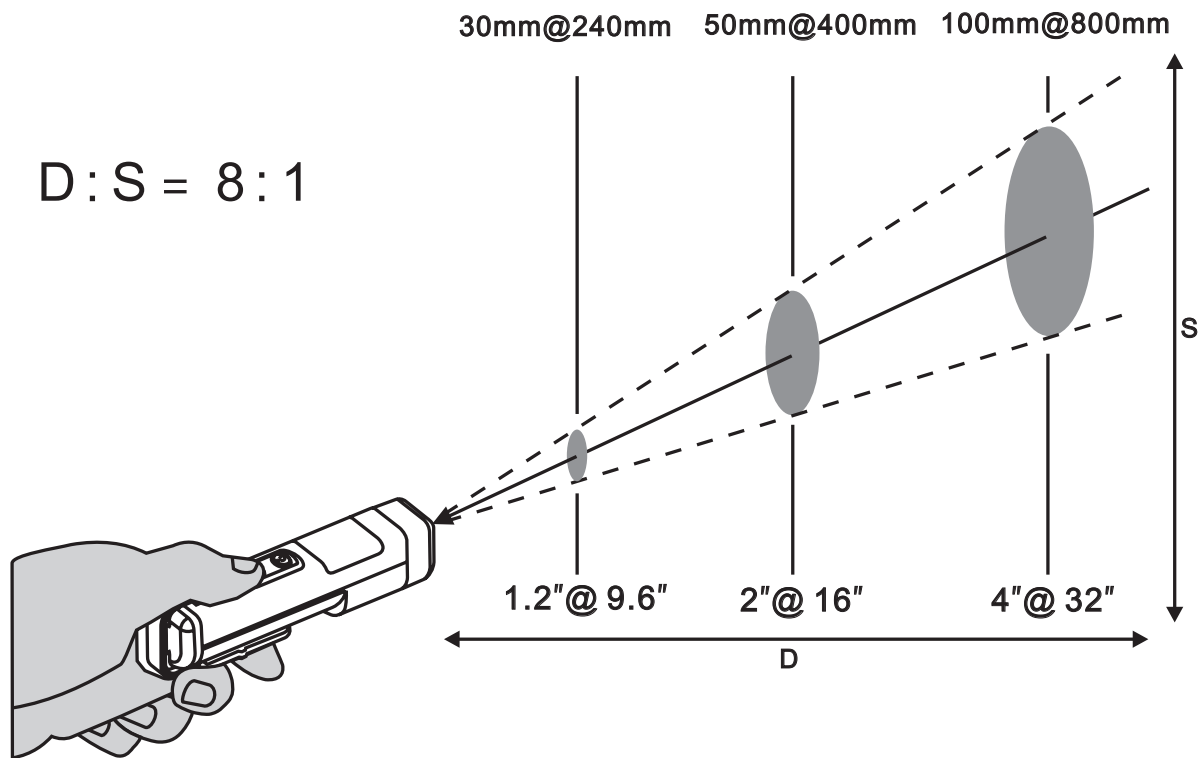

1. The measured area cannot be bigger than target area, or the reading will be incorrect.
2. The minimum measurement area is 3.75 cm (1.5") diameter.

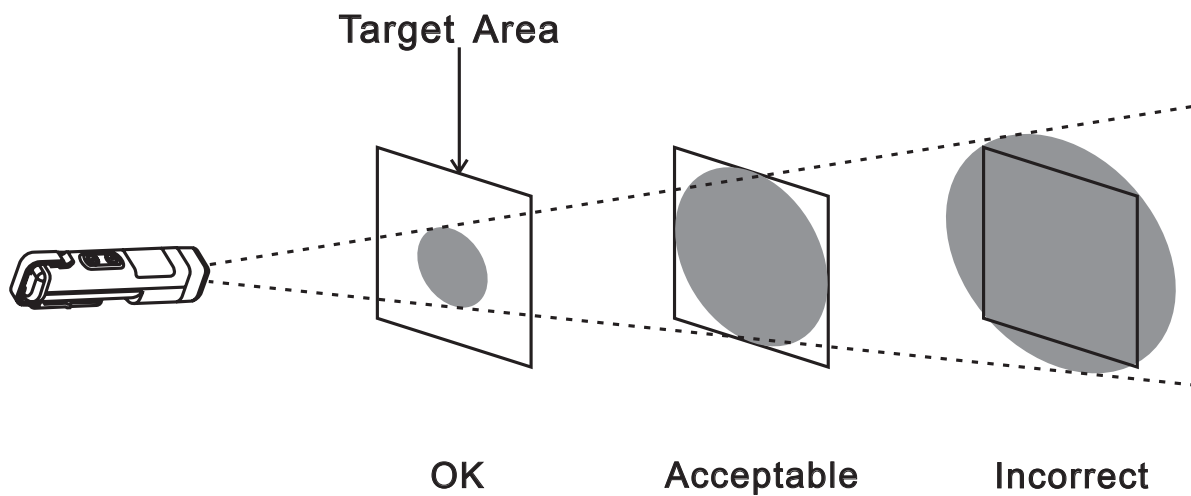

3. It is not recommended for use on measuring shiny or polished metal surfaces (aluminium,, stainless steel etc.).
4. Steam, dust, smoke, etc., can prevent accurate measurement by obstructing the tester's optics

Emissivity

Most organic materials and painted surfaces have an emissivity of 0.95 (pre-set in the tester). Inaccurate readings will result from measuring shiny or polished metal surfaces. To compensate, cover the surface to be measured with masking tape or matt black paint. Allow time for the tape to reach the same temperature as the material underneath it. Measure the temperature of the tape or painted surface.

Torch

When the tester is powered on, press the  key to switch the torch on and off.

Volt Sense (non contact voltage detection)

The Volt Sense function is ON automatically when the tester is switched on and is in standby mode. The LCD displays will display the  indicator.

While an electric field is being sensed, the LCD displays flashing “◆” symbols and the torch flashes.

The higher the electric field sensed, the more “◆” symbols are displays on the LCD and the faster the display and the torch will flash

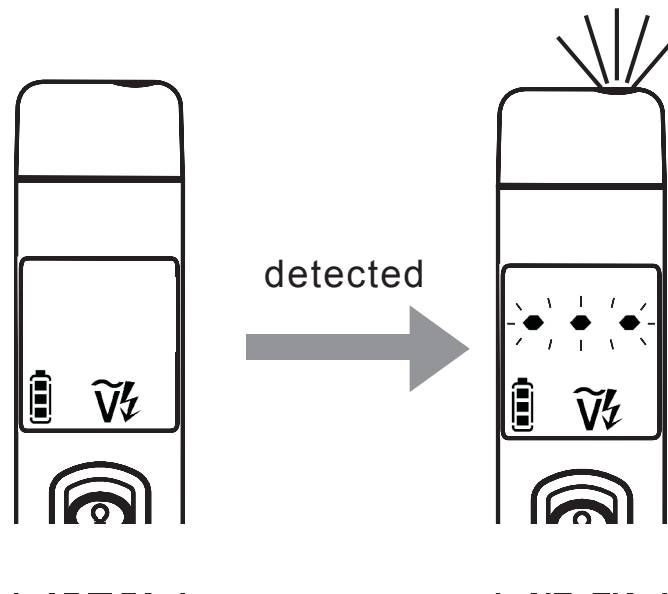

⚠ Safety Information

The Volt Sense function should only be used to test insulated wire.
Testing high voltage wire should keep a distance of 20mm, or it might cause danger.

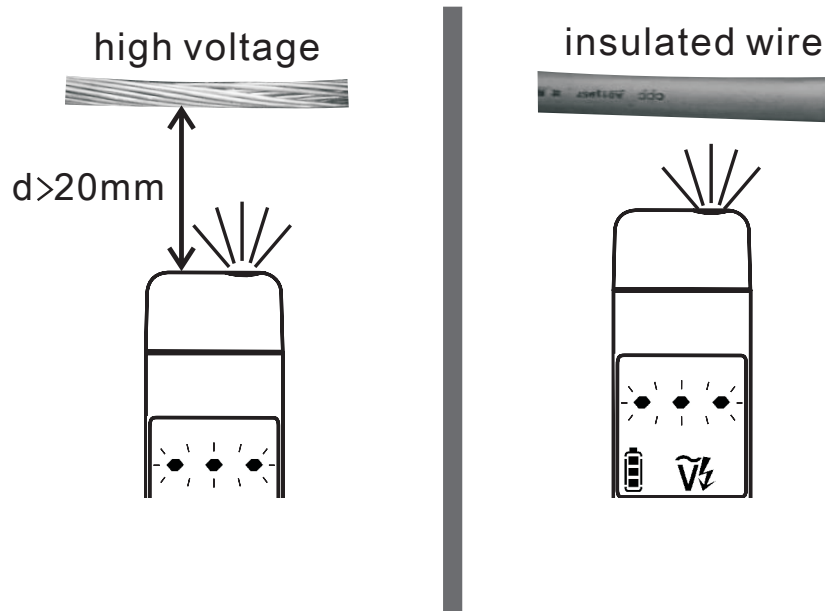

Maintenance

Do not attempt to repair this tester.
It contains no user-serviceable parts.
Repair or service should only be performed by qualified personal.

Battery Replacement

The tester displays the battery capacity when powering up. Replace the battery when the “” battery indicator is flashing.
Open the back cover to replace the battery.

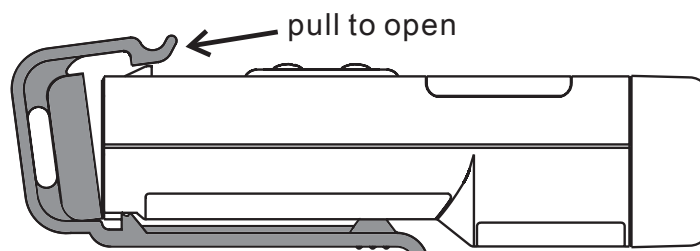

Check the battery polarity carefully when inserting the battery.
Do not short-circuit used batteries, disassemble them, or throw them in a fire. Doing so may cause the batteries to explode.
Dispose of the used batteries in accordance with local regulations.

Cleaning

Periodically wipe the case with a dry cloth and detergent.

Do not use abrasives or solvents.

Do not immerse the tester in water.

Periodically wipe the lens with a cotton swab and rubbing alcohol.

Do not use abrasives or any other solvents.

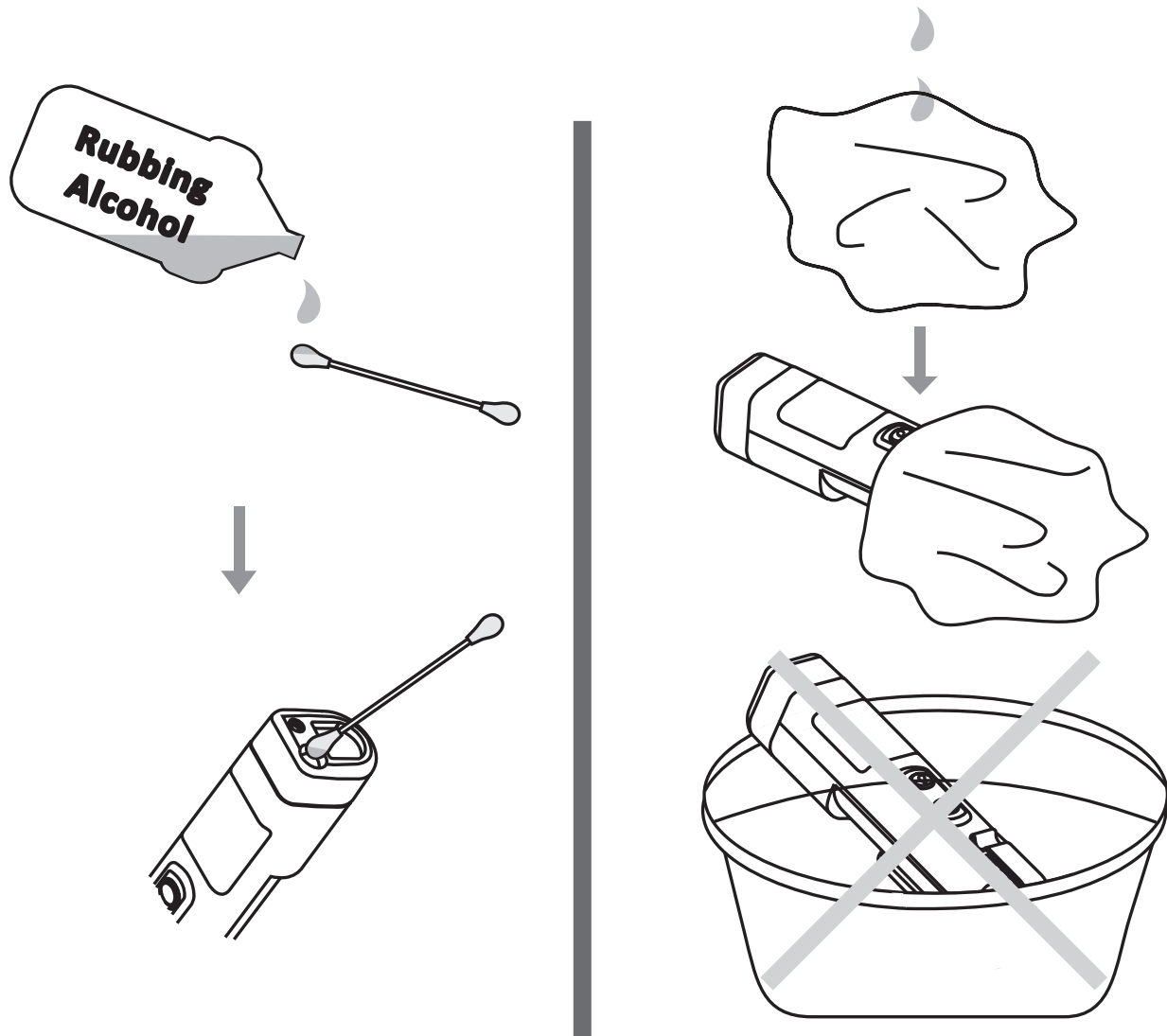

Specifications

Temperature	-30°C ~ 500°C (-22°F ~ 932°F)
Accuracy at 23°C ± 2°C < 80% RH	-30°C ~ 0°C (-22°F ~ 32°F) : ± 3°C (± 6°F) 1°C ~ 10°C (34°F ~ 50°F) : ± 1.5°C (± 4°F) 11°C ~ 40°C (52°F ~ 104°F) : ± 1.5°C (± 3°F) 41°C ~ 500°C (106°F ~ 932°F) : ± 2°C (± 3°F) or ± 4% of reading, whichever is greater.
Display Resolution	0.2°C (0.5°F)
Response Time	0.5 s
Spectral Response	6.5um ~ 18um
Emissivity	E=0.95
D:S	8:1(calculated at 80% energy)
Repeatability	±1°C or ±0.5% of reading, whichever is greater.
Display Hold	10s
Weight / Dimension	40g 20mm(W)x30mm(D)x100mm(L)
Battery Life	150hrs (with laser)
Power	1.5 V AAA alkaline battery
Non-Contact Voltage	60VAC ~ 600VAC
Storage Temperature	-20°C ~ 60°C (without battery)



Africa

RS Components SA

P.O. Box 12182, Vorna Valley, 1686
20 Indianapolis Street, Kyalami Business Park,
Kyalami, Midrand, South Africa

www.rs-components.com

Asia

RS Components Pte Ltd.

31 Tech Park Crescent
Singapore 638040

www.rs-components.com

China

RS Components Ltd.

Suite 23 A-C , East Sea Business Centre
Phase 2 , No. 618 Yan'an Eastern Road
Shanghai, 200001, China

www.rs-components.com

Europe

RS Components Ltd.

PO Box 99, Corby,
Northants. NN17 9RS, United Kingdom

www.rs-components.com

Japan

RS Components Ltd.

West Tower (12th Floor),
Yokohama Business Park, 134 Godocho,
Hodogaya, Yokohama, Kanagawa 240-0005,
Japan

www.rs-components.com

U.S.A

Allied Electronics

7151 Jack Newell Blvd. S.
Fort Worth, Texas 76118 , U.S.A.

www.alliedelec.com

South America

RS Componentes Limitada

Av. Pdte. Eduardo Frei M. 6001-71
Centro Empresas El Cortijo

Conchali, Santiago, Chile
www.rs-components.com