

NOTES: UNLESS OTHERWISE SPECIFIED

1. CORNERS DRAWN SHARP TO BE R.005 MAXIMUM.
2. EXTERIOR SURFACE TEXTURE TO BE LIGHT EDM FINISH. EQUIVALENT TO MT-11010. TEXTURE ON ENCLOSURE WILL VARY FROM TIME TO TIME AS THE TOOL WEARS AND IT BECOMES NECESSARY TO REAPPLY.
3. INTERIOR SURFACE TEXTURE TO BE: NONE.
4. ALL INSIDE RADII .010R. UNLESS OTHERWISE SPECIFIED.
5. ALL EXTERNAL DIMENSIONS AFFECTED BY THE DRAFT APPLY AT THE LARGE END OF THE FEATURE, AND ALL INTERNAL FEATURES AFFECTED BY THE DRAFT APPLY AT THE SMALL END OF THE FEATURE UNLESS OTHERWISE SPECIFIED.
6. 1 DEGREE DRAFT IN THE DIRECTION OF PULL IS PERMISSIBLE UNLESS OTHERWISE SPECIFIED.
7. MATERIAL / COLOR: ABS PLASTIC IS STANDARD IN BLACK OR WHITE. CUSTOM MATERIALS AND COLORS ARE AVAILABLE UPON REQUEST FOR QUOTE. ALTERNATE RESINS HAVE DIFFERENT SHRINK RATES, AND WILL EFFECT DIMENSIONS.
8. PCB SIZES ARE RECOMMENDATIONS ONLY. FINAL SIZES AND VERIFICATION OF ITS FIT ARE THE SOLE RESPONSIBILITY OF EACH CUSTOMER.
9. ASSEMBLY SCREWS FOR THE ENCLOSURE INCLUDED. MOUNTING SCREWS FOR THE PCB ARE SOLD SEPARATELY.
10. THIS DRAWING IS BASED ON A SOLID MODEL, AND IS FURTHER DEFINED BY THE SOLID MODEL FILE.
11. ALLOWABLE FLASH: 0.010 MAX.
12. ALL EJECTOR PIN MARKS TO BE WITHIN 0.010" OF FLUSH, PROTRUDING OR BELOW FLUSH.
13. TRIM GATE WITHIN 0.030" OF FLUSH.



SCALE 1.000

R E V I S I O N					
REV.	DRAWN BY	ECO No	DESCRIPTION	DATE	APPROVE
A	M BOYER		PRELIMINARY RELEASE	2017-May-30	D.C.
B	M BOYER		REVISE SIZE	2017-May-31	D.C.
C	M BOYER		REVISE SIZE FOR ETHERNET	2017-Jun-02	D.C.
D	R CRUZ		REVISE ENVELOPE DIMENSIONS	2017-Jun-06	D.C.
E	R CRUZ		REVISE ENCLOSURE NAME	2017-Jul-25	D.C.
1.0	M BOYER		UPDATE SHEETS AND RELEASE TO REV 1 PER CUSTOMER	2017-Jul-28	

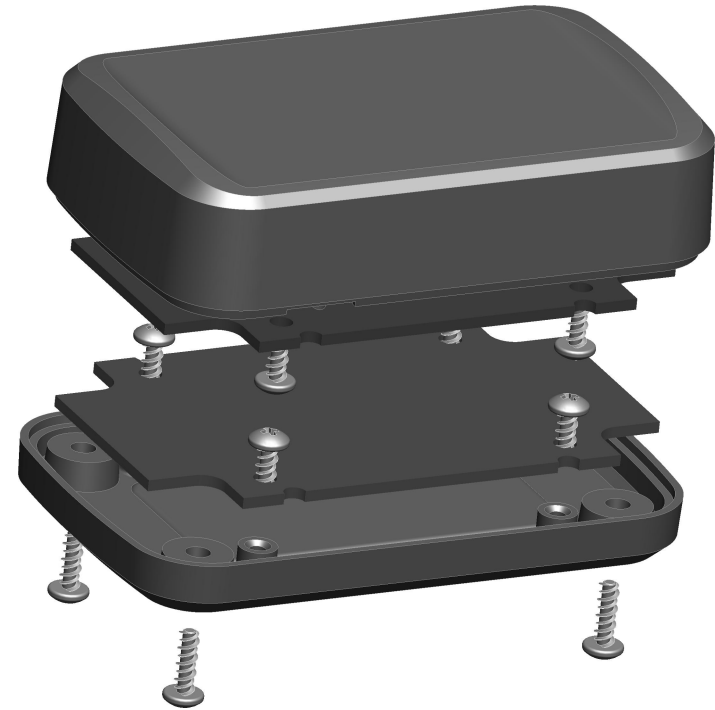

SCALE 1.000

ITEM	FILE NAME	DESCRIPTION	MATERIAL	COLOR	QTY.
6	SCREW_HILO-N04X375	#4 HiLo SCREW x .375"	ZINK PLATED	CUSTOMER SUPPLIED	4
5	SCREW_HILO-N04X250	#4 HiLo SCREW x .250"	ZINK PLATED	CUSTOMER SUPPLIED	8
4	332010_PCB-TOP	332010 TOP PCB - REFERENCE	.062" THICK	CUSTOMER SUPPLIED	1
3	332010_PCB-BOT	332010 BOTTOM PCB - REFERENCE	.062" THICK	CUSTOMER SUPPLIED	1
2	332010_COVER	332010 COVER - STANDARD	ABS	BLACK or WHITE	1
1	332010_BASE	332010 BASE - STANDARD	ABS	BLACK or WHITE	1

BILL OF MATERIALS

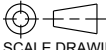
THIRD ANGLE PROJECTION  DO NOT SCALE DRAWING	TOLERANCES: UNLESS OTHERWISE SPECIFIED DIMENSIONS ARE IN U.S. INCHES. X.XX = .015 X.XXXX = .001 X.XXX = .010 X.X" = 1°		<b>NEW AGE ENCLOSURES</b> 2240 South Thornburg Street Santa Maria, CA. 93455 ph. (805) 595-1310 fax (805) 595-1024 <a href="http://www.newageenclosures.com">www.newageenclosures.com</a>	
	Customer's Part No: 332010			
APPROVAL BY DATE		SIZE DRAWING NAME		SHEET REV.DOC 1 OF 6 1.0
CHECK ENG. SCALE AS NOTED		A 332010_R1_0		
DRAWN BY M BOYER		DATE 2017-May-30		

NOTICE: THE INFORMATION AND DATA CONTAINED HEREIN IS CONSIDERED PROPRIETARY TO ALLTEC INTEGRATED MFG INC & SHALL REMAIN THE EXCLUSIVE PROPERTY OF ALLTEC INTEGRATED MFG INC. THE HOLDER WILL ASSUME CUSTODY AND CONTROL THAT THIS DOCUMENT WILL NOT BE COPIED, REPRODUCED, OR DISCLOSED WITHOUT THE EXPRESS WRITTEN CONSENT OF ALLTEC INTEGRATED MFG INC. POSSESSION OF THIS DOCUMENT DOES NOT CONSTITUTE A GRANT TO MANUFACTURE ANY ITEMS. © 2017

# 332010 ASSEMBLY

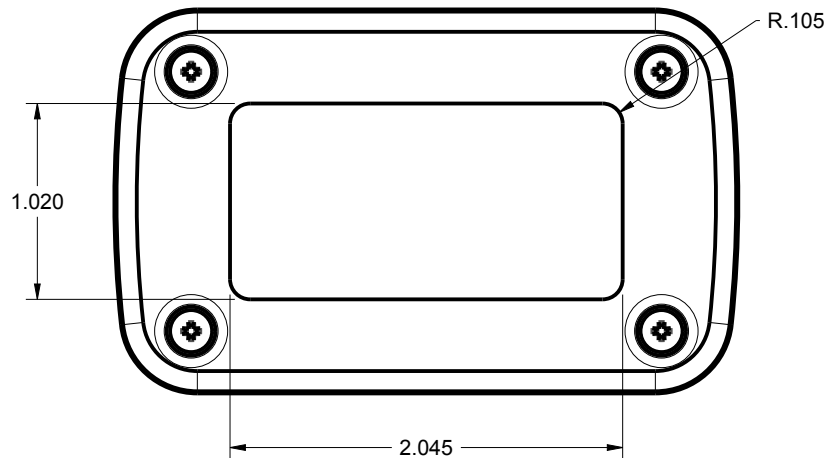
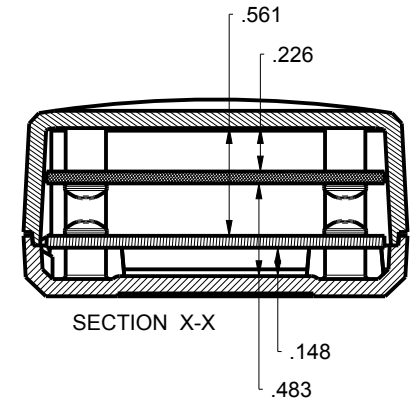
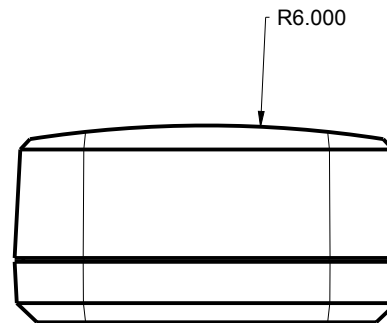
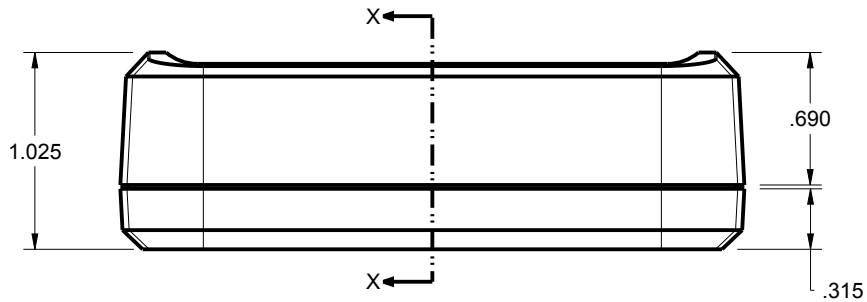
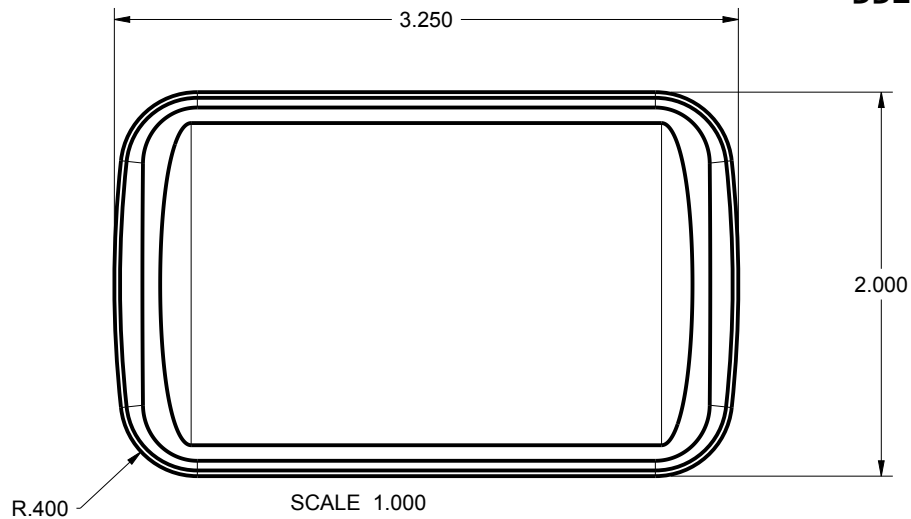

TOLERANCES: UNLESS OTHERWISE SPECIFIED  
DIMENSIONS ARE IN U.S. INCHES.

X.XX = .015 X.XXXX = .001  
X.XXX = .010 X.X° = 1°

**NEW AGE ENCLOSURES**

Customer's Part No: 332010

APPROVAL	BY	DATE
CHECK		
ENG.		
SCALE	AS NOTED	
DRAWN BY	M BOYER	
	2017-May-30	

**NEW AGE ENCLOSURES**

2240 South Thornburg Street Santa Maria, CA. 93455  
ph. (805) 595-1310 fax (805) 595-1024  
[www.newageenclosures.com](http://www.newageenclosures.com)

<b>UTILITY BAR - STANDARD</b>		SHEET	REV.DOC
<b>SXX-332010-XXX</b>		2 OF 6	1.0
SIZE	DRAWING NAME		
A	332010_R1_0		

# 332010 COVER

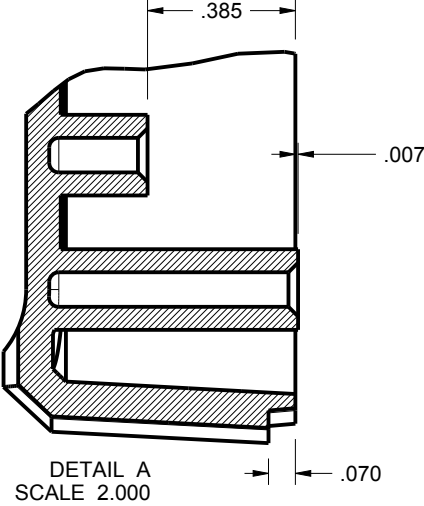
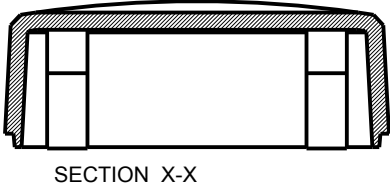
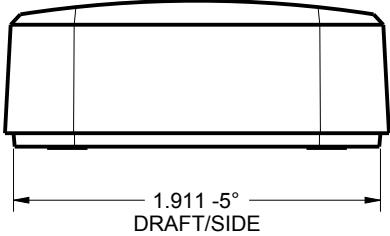
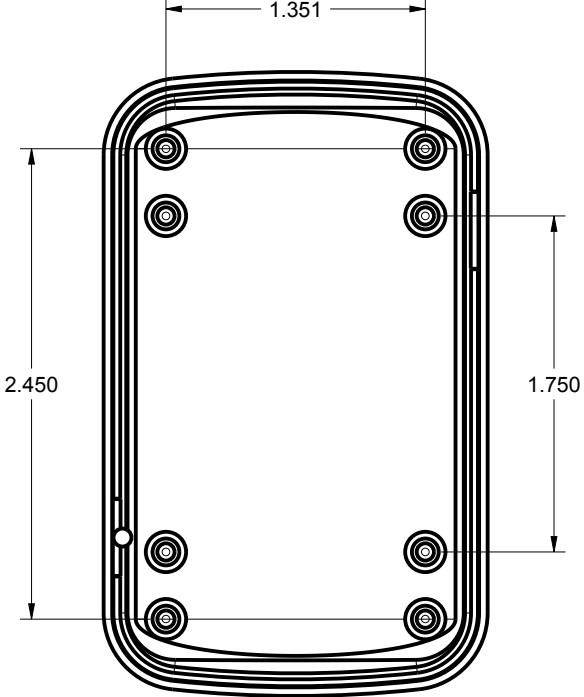
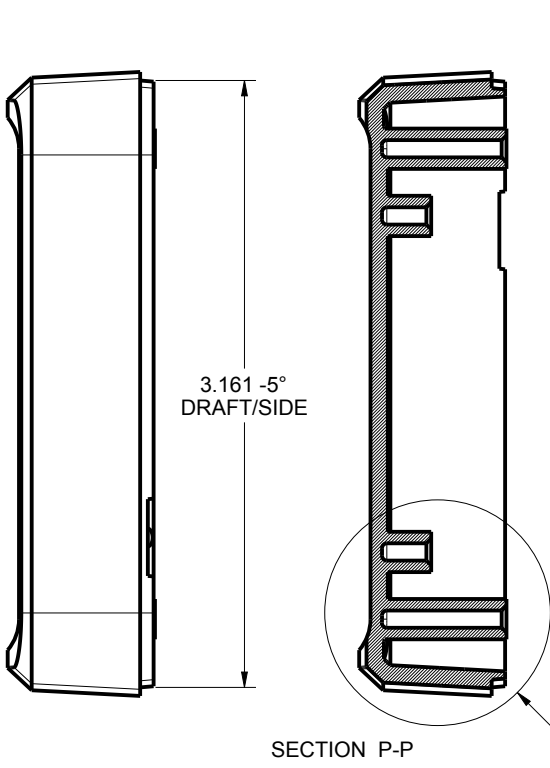
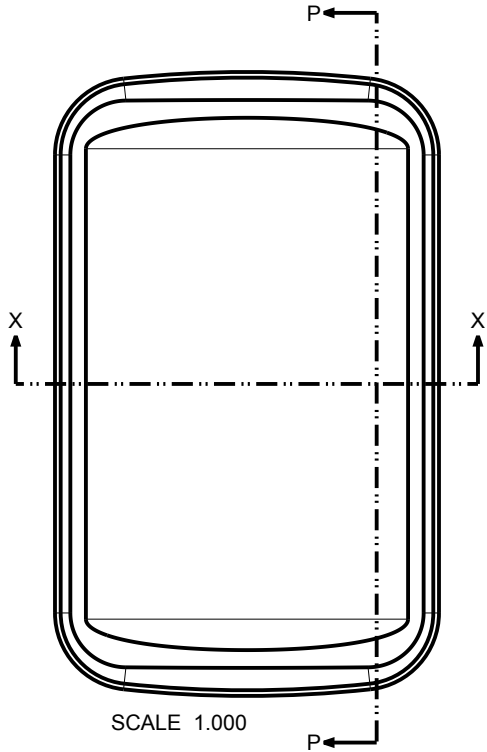

TOLERANCES: UNLESS OTHERWISE SPECIFIED DIMENSIONS ARE IN U.S. INCHES. X.XX = .015 X.XXXX = .001 X.XXX = .010 X.X° = 1°		<b>NEW AGE ENCLOSURES</b>	
NEW AGE ENCLOSURES		2240 South Thornburg Street Santa Maria, CA. 93455 ph. (805) 595-1310 fax (805) 595-1024 www.newageenclosures.com	
Customer's Part No: 332010			
APPROVAL	BY	DATE	
CHECK			
ENG.			
SCALE	AS NOTED		
DRAWN BY	SIZE	DRAWING NAME	SHEET
M BOYER	A	332010_R1_0	3 OF 6
			REV.DOC
			1.0

UTILITY BAR - STANDARD  
SXX-332010-XXX

# 332010 BASE

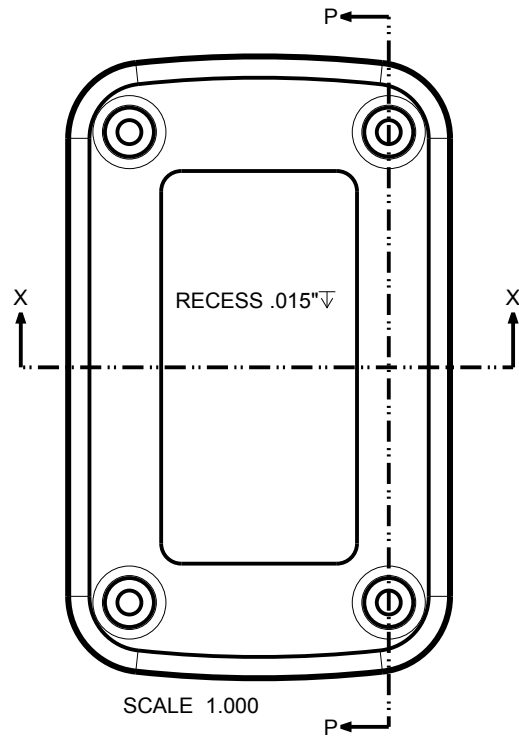

SCALE 1.000

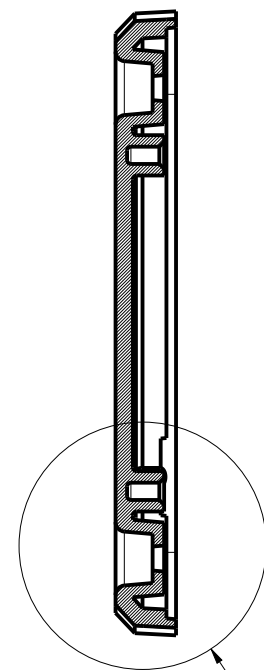
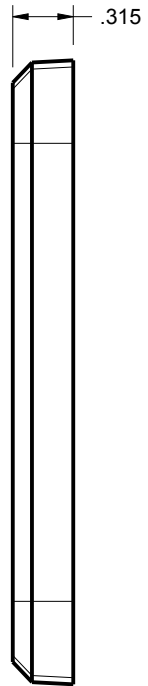

SECTION P-P

SEE DETAIL B

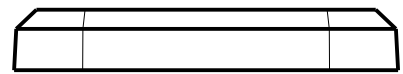
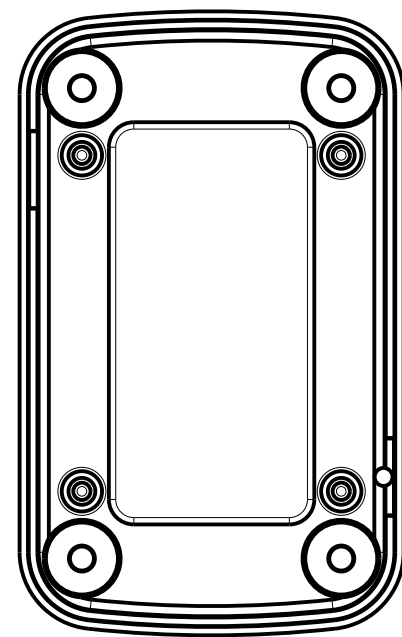

SECTION X-X

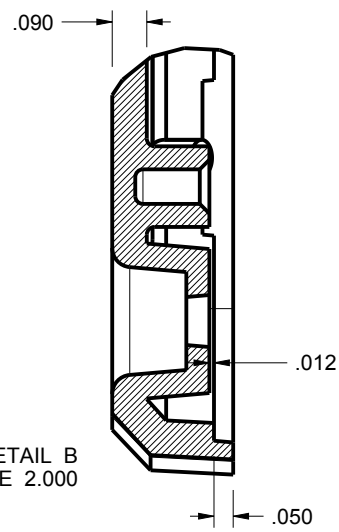

DETAIL B  
SCALE 2.000

TOLERANCES: UNLESS OTHERWISE SPECIFIED DIMENSIONS ARE IN U.S. INCHES.	
X.XX = .015 X.XXXX = .001	
X.XXX = .010 X.X° = 1°	
NEW AGE ENCLOSURES	
Customer's Part No: 332010	
APPROVAL	BY DATE
CHECK	
ENG.	
SCALE	AS NOTED
DRAWN BY	SIZE
M BOYER	A
2017-May-30	DRAWING NAME
	332010_R1_0
SHEET	REV.DOC
4 OF 6	1.0

**NEW AGE ENCLOSURES**  
 2240 South Thornburg Street Santa Maria, CA. 93455  
 ph. (805) 595-1310 fax (805) 595-1024  
[www.newageenclosures.com](http://www.newageenclosures.com)

**UTILITY BAR - STANDARD**  
**SXX-332010-XXX**

# 332010 PCB

PCB SIZES ARE RECOMMENDATIONS ONLY. FINAL SIZES AND VERIFICATION OF ITS FIT ARE THE SOLE RESPONSIBILITY OF THE OEM.

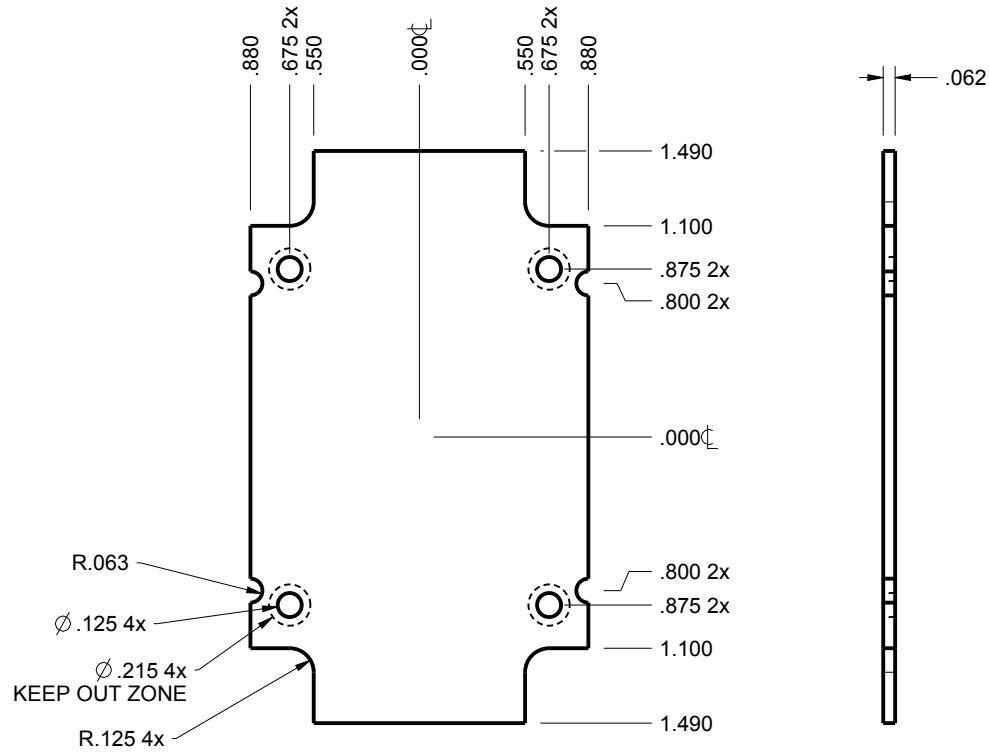

332010 PCB  
SCALE 1.000

TOLERANCES: UNLESS OTHERWISE SPECIFIED DIMENSIONS ARE IN U.S. INCHES. X.XX = .015 X.XXXX = .001 X.XXX = .010 X.X° = 1°		<b>NEW AGE ENCLOSURES</b>	
Customer's Part No: 332010		2240 South Thornburg Street Santa Maria, CA. 93455 ph. (805) 595-1310 fax (805) 595-1024 <a href="http://www.newageenclosures.com">www.newageenclosures.com</a>	
APPROVAL	BY	DATE	UTILITY BAR - STANDARD SXX-332010-XXX
CHECK			
ENG.			
SCALE	AS NOTED		
DRAWN BY M BOYER	2017-May-30	SIZE A	DRAWING NAME 332010_R1_0
		SHEET 5 OF 6	REV.DOC 1.0

### 332010 2nd OPERATION

NEW AGE ENCLOSURES DELIVERS YOUR ENCLOSURE MARKET-READY WITH IN-HOUSE  
 CNC MACHINING, PAD PRINTING, ASSEMBLY, AND FULFILLMENT.  
 ALL SURFACES AND AREAS ARE AVAILABLE FOR CNC ALTERATION BY NEW AGE ENCLOSURES  
 CALL (805) 595-1310 FOR PRICING AND SCHEDULE.  
 THE INSIDE RADIUS OF ANY MACHINED FEATURES SHOULD BE NO SMALLER THAN .031"



332010 COVER  
 SCALE 1.000

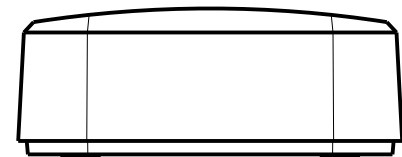
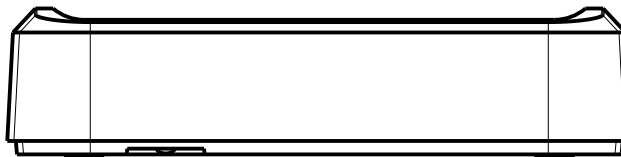
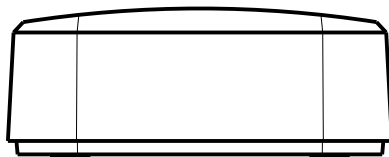

TOLERANCES: UNLESS OTHERWISE SPECIFIED  
 DIMENSIONS ARE IN U.S. INCHES.  
 X.XX = .015 X.XXXX = .001  
 X.XXX = .010 X.X° = 1°

NEW AGE ENCLOSURES  
 Customer's Part No: 332010

**NEW AGE ENCLOSURES**  
 2240 South Thornburg Street Santa Maria, CA. 93455  
 ph. (805) 595-1310 fax (805) 595-1024  
[www.newageenclosures.com](http://www.newageenclosures.com)

SXX-332010-XXX COVER - ABS, BLACK					
STEP	DESCRIPTION	CUTTER	FIXTURE	ORIENTATION	PROGRAM
1-C-C1	-	T2 = .062" EM	-	-	o1001
2-C-C2	-	T2 = .062" EM	-	-	o1002

APPROVAL	BY	DATE
CHECK		
ENG.		
SCALE	AS NOTED	
DRAWN BY	2017-May-30	
M BOYER		

UTILITY BAR - STANDARD SXX-332010-XXX		SIZE	DRAWING NAME	SHEET	REV.DOC
		A	332010_R1_0	6 OF 6	1.0