

Electronic housing - EMG 75-LG - 2947378

Please be informed that the data shown in this PDF Document is generated from our Online Catalog. Please find the complete data in the user's documentation. Our General Terms of Use for Downloads are valid (<http://phoenixcontact.com/download>)



Electronic housing, for PCB insertion, without screw connection terminal blocks and cover

Why buy this product

- ✓ Choice of four cover sizes in transparent or color versions
- ✓ Practical and easy-to-wire conductor connections
- ✓ Space-saving accommodation of electronic components in finely graded module versions available with 10 to 150 mm pitch
- ✓ User-friendly and safe mounting on DIN rails according to EN 60715
- ✓ Uniform and appropriate housing technology
- ✓ High degree of flexibility due to the wide choice of versions
- ✓ Inflammability class V0 insulation material (according to UL 94)
- ✓ Shock and contamination-proof accommodation of electronic components
- ✓ Universal PCBs for all pitches

Key Commercial Data

Packing unit	5 STK
GTIN	
GTIN	4017918082710

Technical data

General

Housing type	Component housing
Housing material	Polycarbonate fiber reinforced
Color (RAL)	green

Ambient conditions

Ambient temperature (operation)	-40 °C ... 125 °C
---------------------------------	-------------------

Dimensions

Length	75 mm
--------	-------

Electronic housing - EMG 75-LG - 2947378

Technical data

Dimensions

Constructional height	47.5 mm
Width	75 mm
Pitch	5 mm
Depth	75 mm

Technical data

Power dissipation without gap	3.3 W
Power dissipation with 20 mm gap	3.9 W
Number of positions	28

Connection data

Conductor cross section solid min.	0.2 mm ²
Conductor cross section solid max.	4 mm ²
Conductor cross section flexible min.	0.2 mm ²
Conductor cross section flexible max.	2.5 mm ²
Conductor cross section AWG min.	24
Conductor cross section AWG max.	12
Stripping length	8 mm

Standards and Regulations

Flammability rating according to UL 94	V0
----------------------------------------	----

Environmental Product Compliance

China RoHS	Environmentally friendly use period: unlimited = EFUP-e
	No hazardous substances above threshold values

Drawings

Dimensional drawing

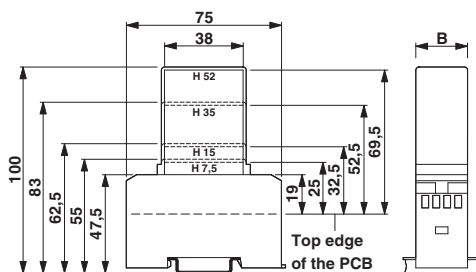

Dimensional drawing

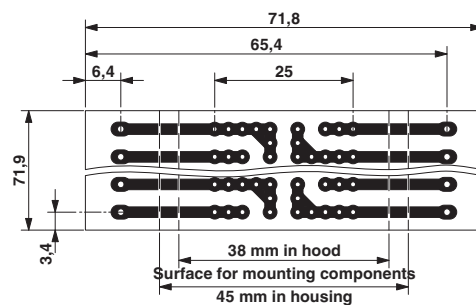

1 = Top edge of the PCB
B = Housing width

Pitch 5 mm
a = Area for mounting components, 38 mm in the hood
b = Area for mounting components, 45 mm in the housing

Electronic housing - EMG 75-LG - 2947378

Approvals

Approvals

Approvals

EAC

Ex Approvals

Approval details

EAC		B.01742
-----	-----------------------------------------------------------------------------------	---------

Phoenix Contact 2018 © - all rights reserved
<http://www.phoenixcontact.com>

PHOENIX CONTACT GmbH & Co. KG
Flachsmarktstr. 8
32825 Blomberg
Germany
Tel. +49 5235 300
Fax +49 5235 3 41200
<http://www.phoenixcontact.com>