

Signal duplicator - MINI MCR-2-UNI-UI-2UI - 2905026

Please be informed that the data shown in this PDF Document is generated from our Online Catalog. Please find the complete data in the user's documentation. Our General Terms of Use for Downloads are valid (<http://phoenixcontact.com/download>)



Universally configurable 4-way signal duplicator, with plug-in connection technology for the electrical isolation and duplication of analog signals. Configurable via DIP switch or software. Screw connection technology, standard configuration.



Key Commercial Data

Packing unit	1 STK
GTIN	 4 046356 915243
GTIN	4046356915243

Technical data

Note

Utilization restriction	EMC: class A product, see manufacturer's declaration in the download area
-------------------------	---

Dimensions

Width	6.2 mm
Height	110.5 mm
Depth	120.5 mm

Ambient conditions

Ambient temperature (operation)	-40 °C ... 70 °C
Ambient temperature (storage/transport)	-40 °C ... 85 °C

Input data

Number of inputs	1
Configurable/programmable	Yes
Voltage input signal	0 V ... 10 V (via DIP switch)
	2 V ... 10 V (via DIP switch)
	0 V ... 5 V (via DIP switch)

Signal duplicator - MINI MCR-2-UNI-UI-2UI - 2905026

Technical data

Input data

	1 V ... 5 V (via DIP switch)
	0 V ... 12 V (can be set via software)
Current input signal	0 mA ... 20 mA (via DIP switch)
	4 mA ... 20 mA (via DIP switch)
	0 mA ... 10 mA (via DIP switch)
	20 mA ... 0 mA (via DIP switch)
	0 mA ... 24 mA (can be set via software)
max. input voltage	12 V
Max. input current	24 mA
Input resistance of voltage input	> 120 k Ω
Input resistance current input	approx. 50 Ω (+ 0.7 V for test diode)

Output data

Number of outputs	2
Voltage output signal	0 V ... 10 V (via DIP switch)
	2 V ... 10 V (via DIP switch)
	0 V ... 5 V (via DIP switch)
	1 V ... 5 V (via DIP switch)
	0 V ... 10.5 V (can be set via software)
Current output signal	0 mA ... 20 mA (via DIP switch)
	4 mA ... 20 mA (via DIP switch)
	0 mA ... 10 mA (via DIP switch)
	20 mA ... 0 mA (via DIP switch)
	0 mA ... 21 mA (can be set via software)
Max. output voltage	approx. 12.3 V
Max. output current	24.6 mA
Short-circuit current	\leq 25 mA
Load/output load voltage output	\geq 10 k Ω
Load/output load current output	\leq 600 Ω (per channel)
Ripple	< 20 mV _{PP} (at 600 Ω)
	< 20 mV _{PP} (at 600 Ω)

Power supply

Nominal supply voltage	24 V DC
Supply voltage range	9.6 V DC ... 30 V DC (The DIN rail bus connector (ME 6,2 TBUS-2 1,5/5-ST-3,81 GN, Order No. 2869728) can be used to bridge the supply voltage. It can be snapped onto a 35 mm DIN rail according to EN 60715))
Typical current consumption	55 mA (24 V DC)
	110 mA (12 V DC)
Power consumption	1.5 W (at I _{OUT} = 20 mA, 9.6 V DC, 600 Ω load)

Connection data

Signal duplicator - MINI MCR-2-UNI-UI-2UI - 2905026

Technical data

Connection data

Connection method	Screw connection
Single conductor/terminal point, solid, with ferrule, min.	0.2 mm ²
Single conductor/terminal point, solid, with ferrule, max.	1.5 mm ²
Single conductor/terminal point, solid, without ferrule, min.	0.2 mm ²
Single conductor/terminal point, solid, without ferrule, max.	2.5 mm ²
Conductor cross section flexible min.	0.2 mm ²
Conductor cross section flexible max.	1.5 mm ²
Min. AWG conductor cross section, flexible	24
Max. AWG conductor cross section, flexible	12
Stripping length	10 mm
Screw thread	M3

General

No. of channels	2
Maximum transmission error	0.05 % (of final value)
Maximum temperature coefficient	0.01 %/K
Step response (10-90%)	approx. 140 ms (15 Hz sample rate)
	approx. 45 ms (60 Hz sample rate)
	approx. 25 ms (240 Hz sample rate)
Electrical isolation	Reinforced insulation in accordance with IEC 61010-1
Overvoltage category	II
Degree of pollution	2
Rated insulation voltage	300 V
Test voltage, input/output/supply	3 kV (50 Hz, 1 min.)
Electromagnetic compatibility	Conformance with EMC directive
Noise emission	EN 61000-6-4
Noise immunity	EN 61000-6-2 When being exposed to interference, there may be minimal deviations.
Color	gray
Housing material	PBT
Mounting position	any
Assembly instructions	The T connector can be used to bridge the supply voltage. It can be snapped onto a 35 mm DIN rail according to EN 60715.
Conformance	CE-compliant
ATEX	# II 3 G Ex nA IIC T4 Gc X
UL, USA/Canada	UL 508 Listed
	Class I, Div. 2, Groups A, B, C, D T6
	Class I, Zone 2, Group IIC T6
GL	GL applied for
Fire protection for rail vehicles (DIN EN 45545-2) R22	HL 1 - HL 2
Fire protection for rail vehicles (DIN EN 45545-2) R23	HL 1 - HL 2
Fire protection for rail vehicles (DIN EN 45545-2) R24	HL 1 - HL 2

Signal duplicator - MINI MCR-2-UNI-UI-2UI - 2905026

Technical data

EMC data

Designation	Electromagnetic RF field
Standards/regulations	EN 61000-4-3
Typical deviation from the measuring range final value	0.2 %
Designation	Fast transients (burst)
Standards/regulations	EN 61000-4-4
Typical deviation from the measuring range final value	0.1 %
Designation	Conducted interferences
Standards/regulations	EN 61000-4-6
Typical deviation from the measuring range final value	2.8 %

Standards and Regulations

Electromagnetic compatibility	Conformance with EMC directive
Noise emission	EN 61000-6-4
Standards/regulations	EN 61000-4-2
Designation	Electromagnetic RF field
Standards/regulations	EN 61000-4-3
	EN 61000-4-4
	EN 61000-4-5
Designation	Conducted interferences
Standards/regulations	EN 61000-4-6
Electrical isolation	Reinforced insulation in accordance with IEC 61010-1
Conformance	CE-compliant
ATEX	# II 3 G Ex nA IIC T4 Gc X
UL, USA/Canada	UL 508 Listed
	Class I, Div. 2, Groups A, B, C, D T6
	Class I, Zone 2, Group IIC T6
GL	GL applied for
Fire protection for rail vehicles (DIN EN 45545-2) R22	HL 1 - HL 2 HL 1 - HL 2 HL 1 - HL 2
Fire protection for rail vehicles (DIN EN 45545-2) R23	HL 1 - HL 2 HL 1 - HL 2 HL 1 - HL 2
Fire protection for rail vehicles (DIN EN 45545-2) R24	HL 1 - HL 2 HL 1 - HL 2 HL 1 - HL 2
Fire protection for rail vehicles (DIN EN 45545-2) R26	HL 1 - HL 2 HL 1 - HL 2 HL 1 - HL 2

Environmental Product Compliance

China RoHS	Environmentally Friendly Use Period = 50
	For details about hazardous substances go to tab "Downloads", Category "Manufacturer's declaration"

Drawings

Signal duplicator - MINI MCR-2-UNI-UI-2UI - 2905026

Block diagram

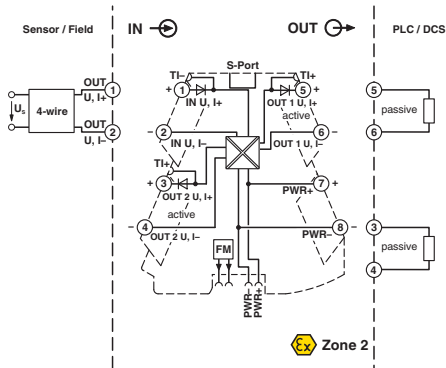

Pictogram

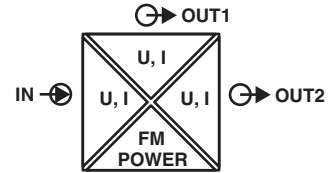

Approvals

Approvals

Approvals

UL Listed / cUL Listed / EAC / cULus Listed

Ex Approvals

UL Listed / cUL Listed / ATEX / cULus Listed

Approval details

UL Listed		http://database.ul.com/cgi-bin/XYV/template/LISEXT/1FRAME/index.htm	FILE E 238705
cUL Listed		http://database.ul.com/cgi-bin/XYV/template/LISEXT/1FRAME/index.htm	FILE E 238705
EAC			RU C- DE.A*30.B.01082
cULus Listed			

Phoenix Contact 2018 © - all rights reserved
<http://www.phoenixcontact.com>

PHOENIX CONTACT GmbH & Co. KG
Flachmarktstr. 8
32825 Blomberg
Germany
Tel. +49 5235 300
Fax +49 5235 3 41200
<http://www.phoenixcontact.com>