

THIS DRAWING IS UNPUBLISHED. RELEASED FOR PUBLICATION 20
 © COPYRIGHT 20 BY - ALL RIGHTS RESERVED.

REVISIONS				
P	LTR	DESCRIPTION	DATE	APVD
	A	REVISED PER ECO-17-010648	21JUL2017	RK DD

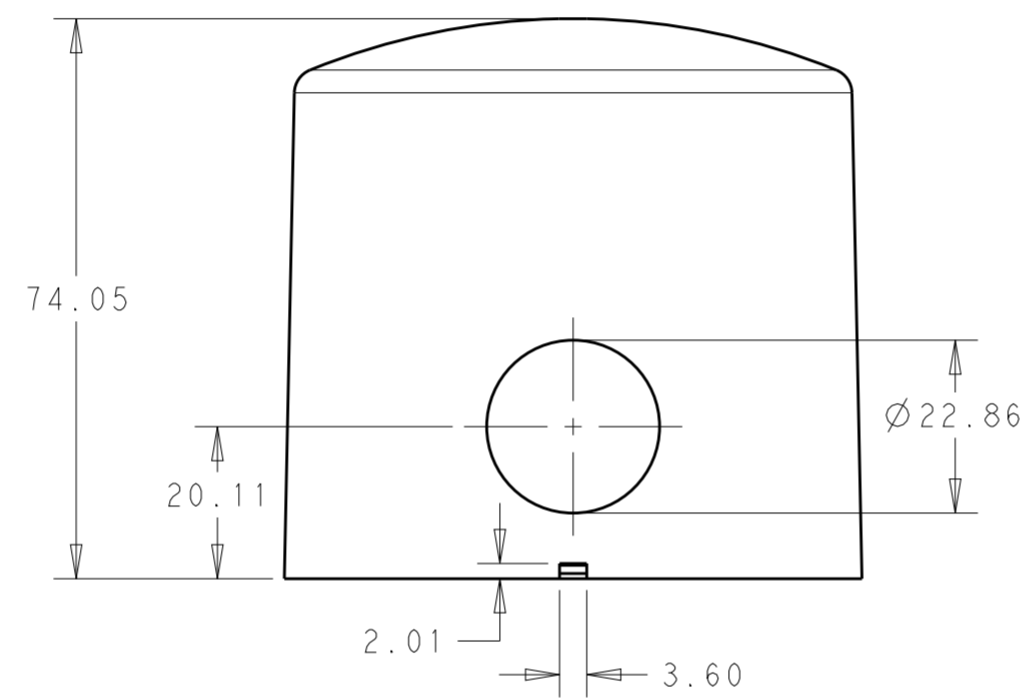

SECTION A - A

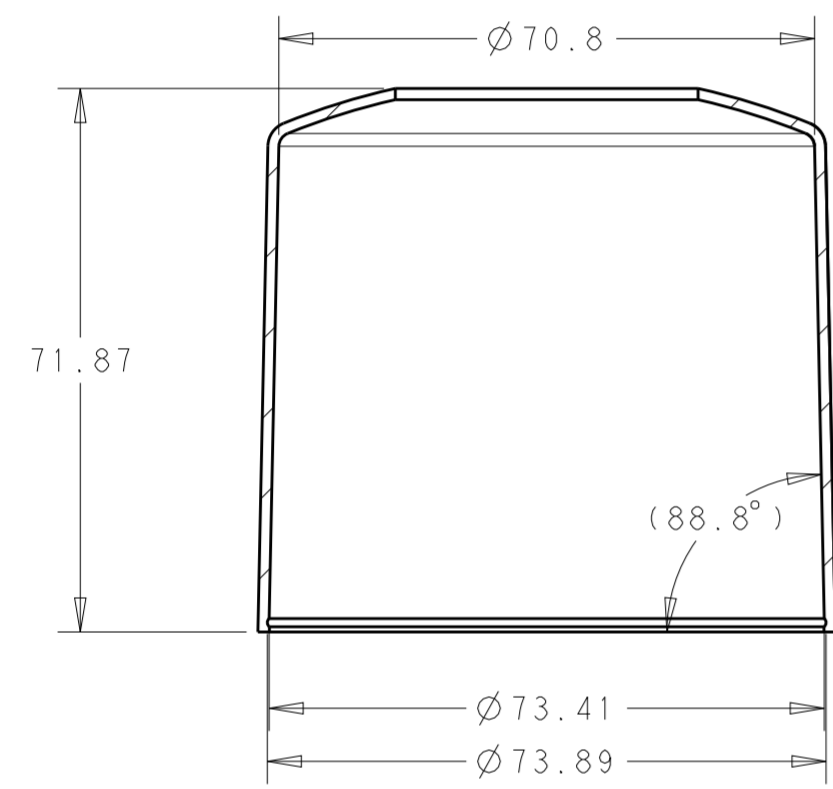
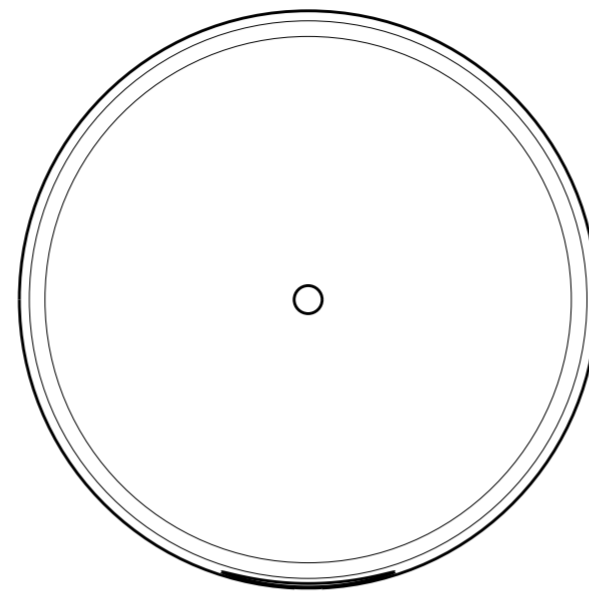
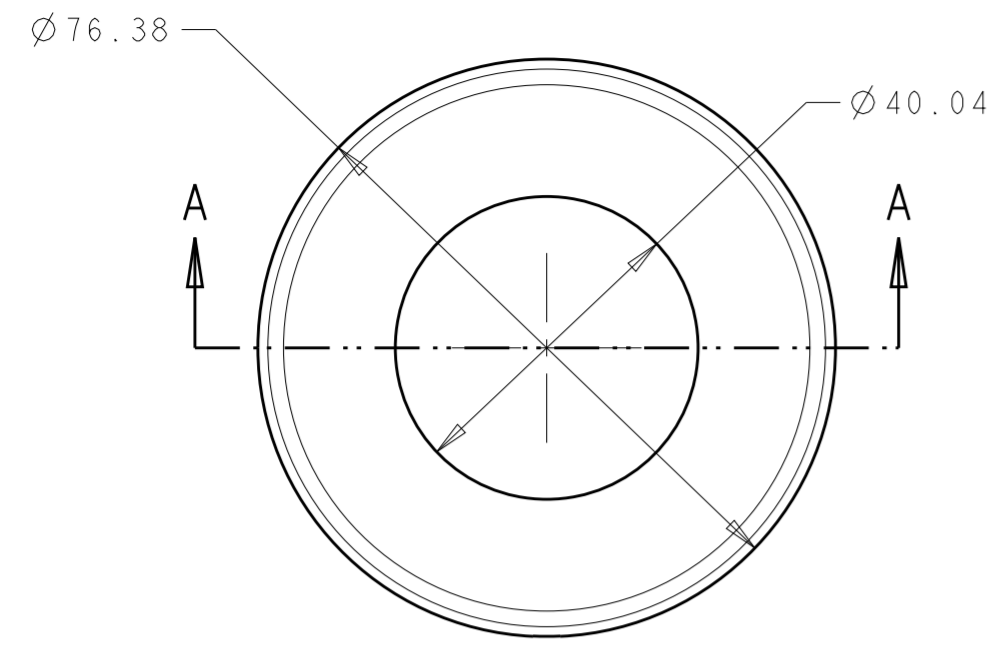
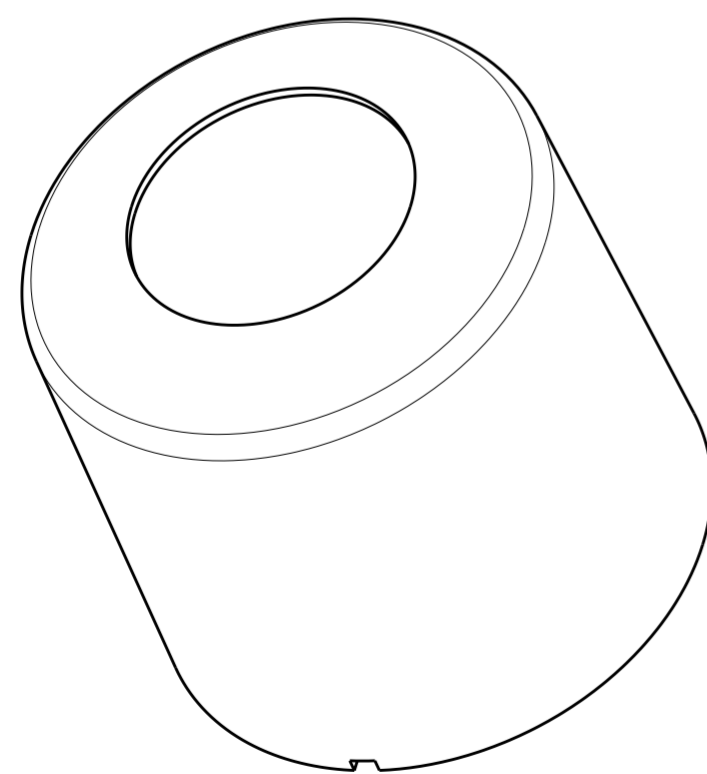

2213996-1, 2213996-2
SHOWN

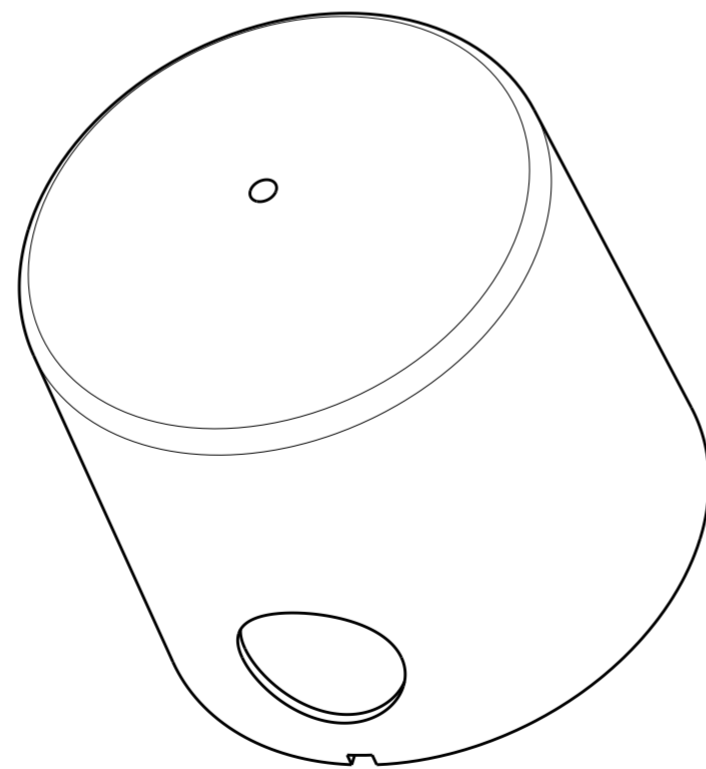

1-2213996-1
SHOWN

NOTES:

- 1 MATERIAL: PBT
- 2 MATING LIGHT CONTROLLER BASE ASSEMBLY TO P/N 2213871-2 AND 1-2213871-2.
- 3. THIS PRODUCT HAS NOT COMPLETED VALIDATION TESTING.
- 4 DOME P/N 2306130-1 OR 1-2306130-1 TO BE USED WITH SLEEVE P/N 2213996.
- 5 MAX ALLOWABLE PCB DIAMETER= \varnothing 72.00

SIDE HOLE	JET BLACK	1-2213996-1
TOP HOLE	WHITE ALUMINUM	2213996-2
TOP HOLE	JET BLACK	2213996-1
DESCRIPTION	COLOR	PART NO.

THIS DRAWING IS A CONTROLLED DOCUMENT.		DWN J. SHAFFER 13JUN2016	APVD E. HOWARD 13JUN2016		TE Connectivity NAME SLEEVE, CONTROLLER, LIGHT BASE, 81MM DIA
DIMENSIONS:	TOLERANCES UNLESS OTHERWISE SPECIFIED:	PRODUCT SPEC	APPLICATION SPEC	RESTRICTED TO	
mm	0 PLC ± 1 PLC ±0.3 2 PLC ±0.25 3 PLC ± 4 PLC ±	108-32125	114-32159		
MATERIAL	FINISH	WEIGHT	SCALE	SHEET	REV
1	-	-	1:1	1 OF 2	A

THIS DRAWING IS UNPUBLISHED. RELEASED FOR PUBLICATION 20
 © COPYRIGHT 20 BY - ALL RIGHTS RESERVED.

REVISIONS				
P	LTR	DESCRIPTION	DATE	APVD
-		SEE SHEET 1	-	-

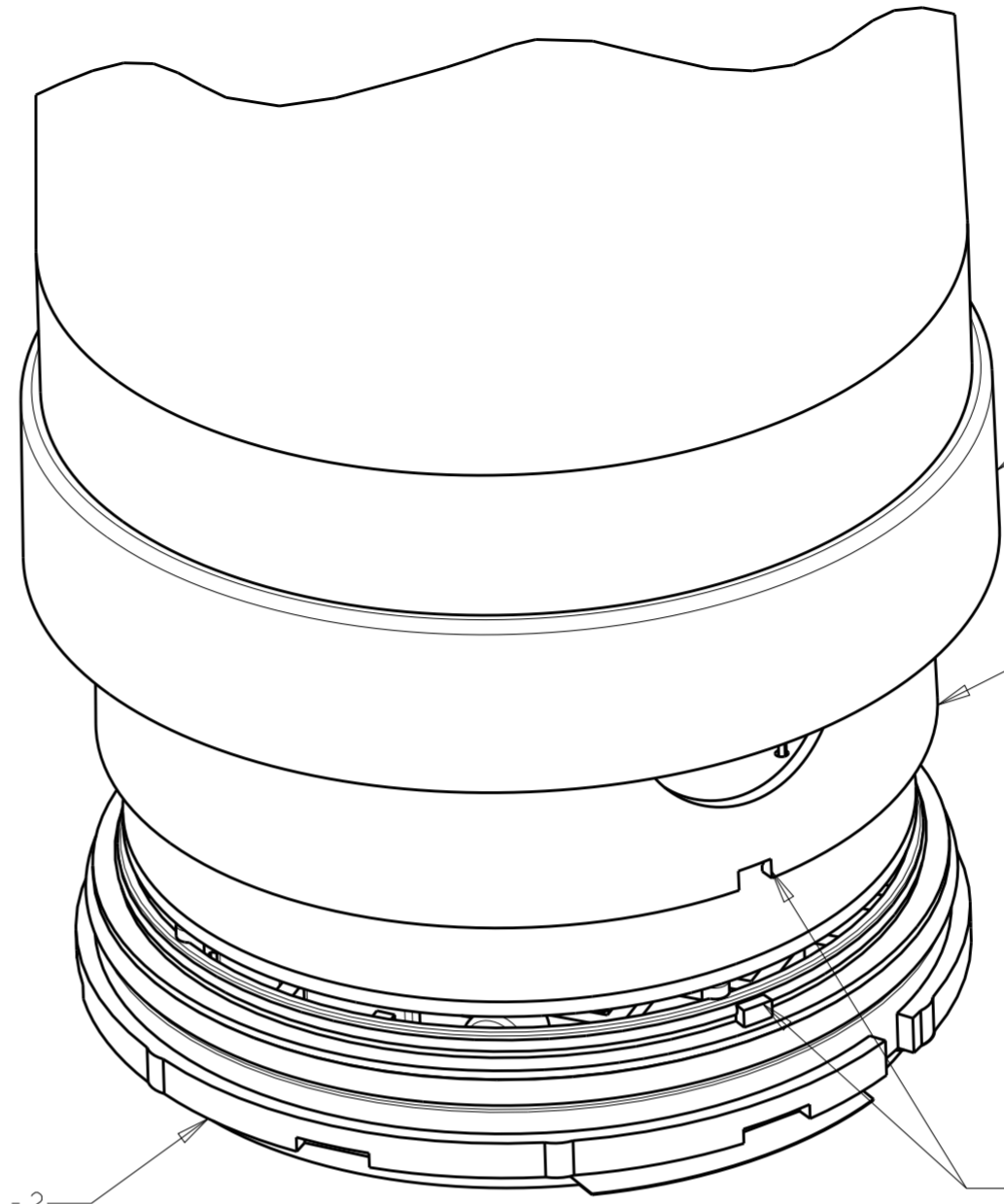
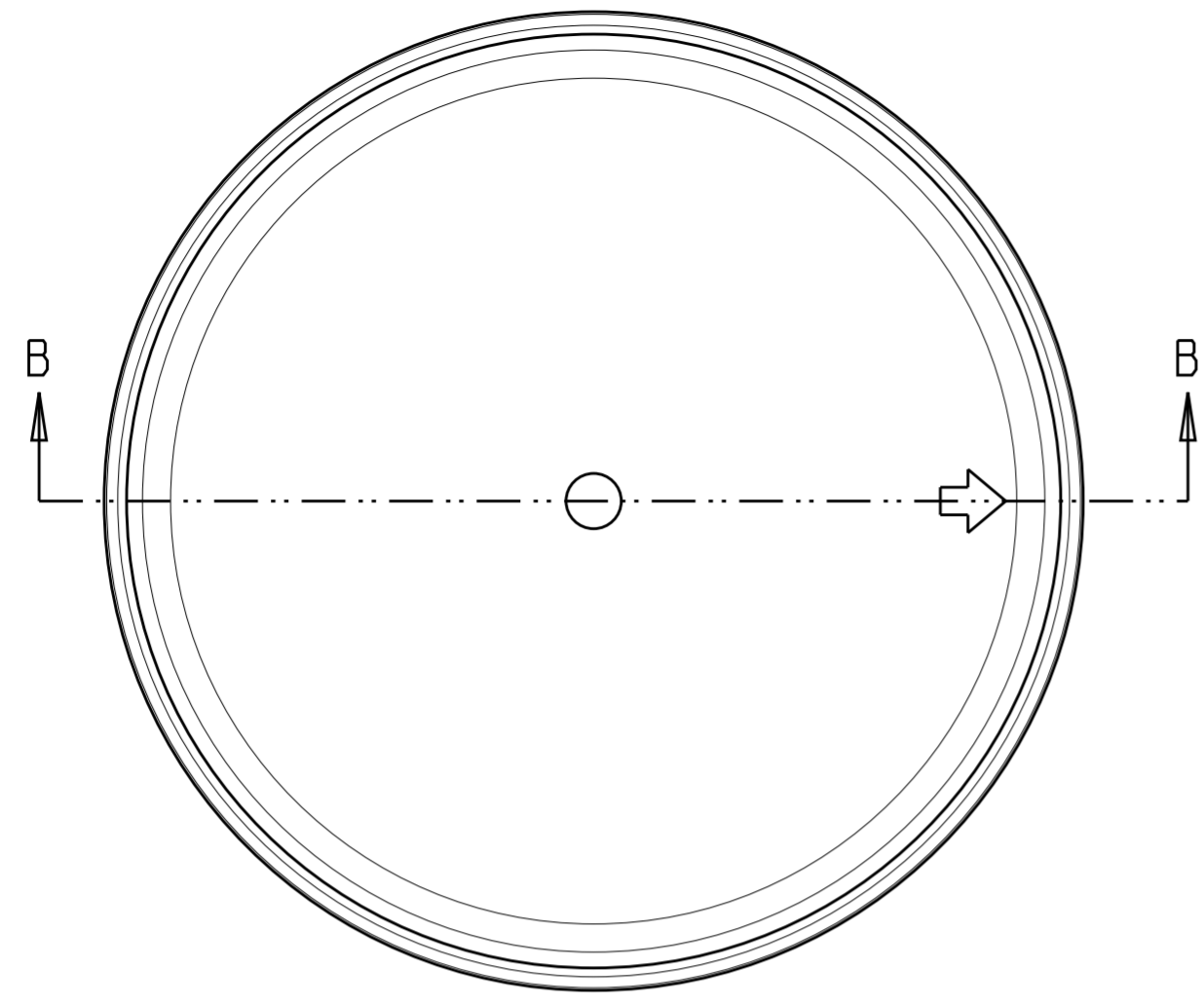

DOME P/N: 2306130-1
1-2306130-1

SLEEVE P/N: 2213996-1
2213996-2
1-2213996-1

BASE ASSEMBLY: 2213871-2
1-2213871-2

ALIGN KEY FEATURE IN SLEEVE TO KEY IN BASE ASSEMBLY

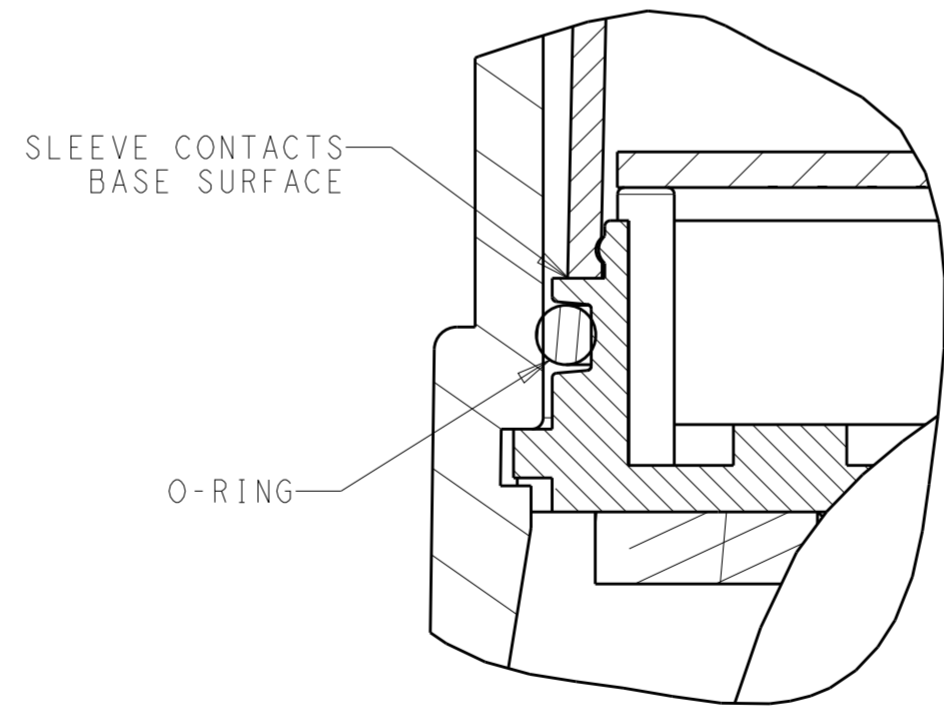
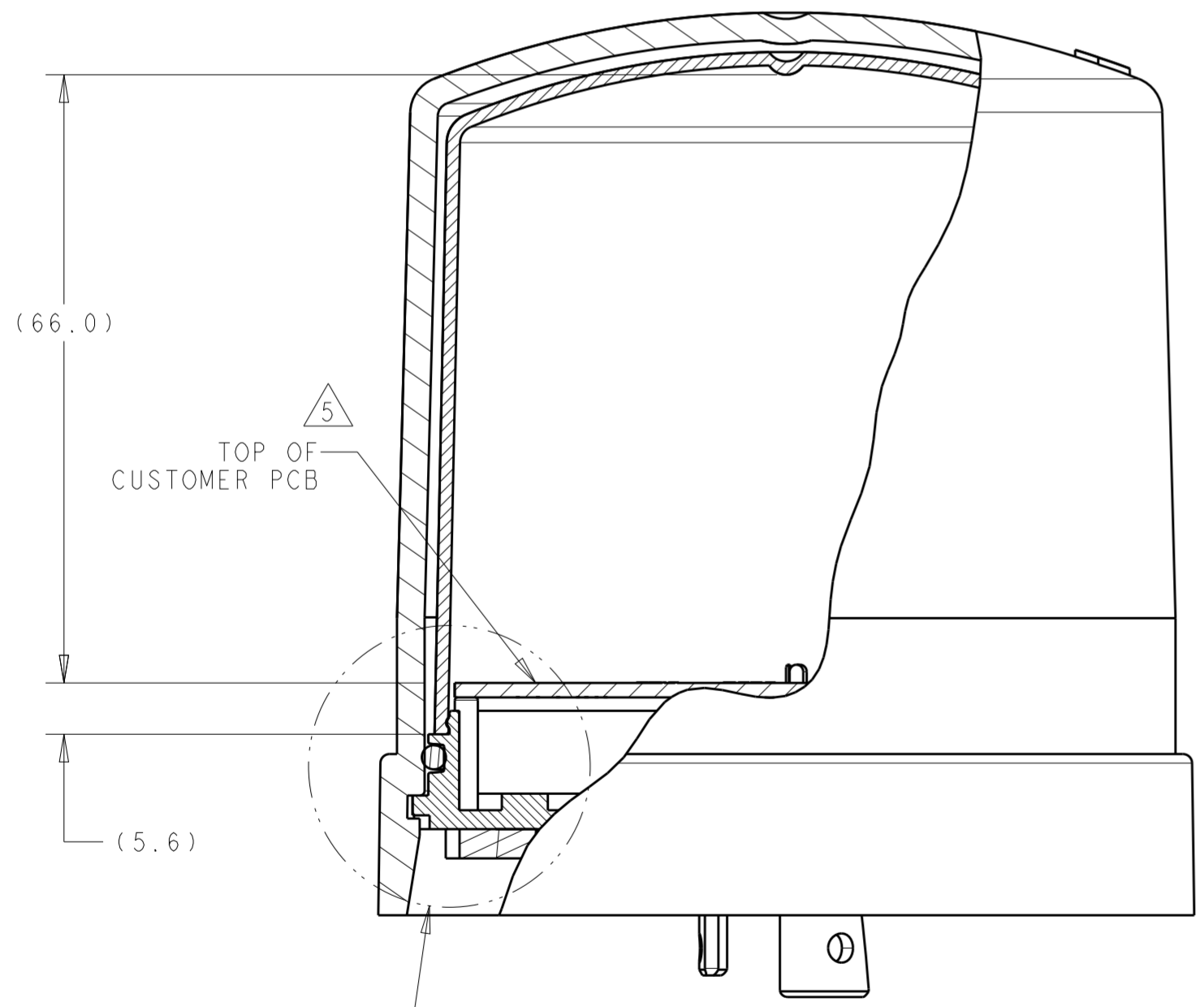

DETAIL A
SCALE 3:1

SEE DETAIL A

SECTION B-B
SCALE 3:2

THIS DRAWING IS A CONTROLLED DOCUMENT.		DWN J. SHAFFER 13 JUN 2016	TE Connectivity	
		CHK E. HOWARD 13 JUN 2016		
DIMENSIONS: mm		APVD -	NAME SLEEVE, CONTROLLER, LIGHT BASE, 81MM DIA	
TOLERANCES UNLESS OTHERWISE SPECIFIED: 0 PLC ± 1 PLC ±0.3 2 PLC ±0.25 3 PLC ± 4 PLC ± ANGLES ± FINISH -		PRODUCT SPEC 108-32125	SIZE A2	
MATERIAL		APPLICATION SPEC 114-32159	CAGE CODE -	DRAWING NO C-2213996
		WEIGHT -	RESTRICTED TO -	
		CUSTOMER DRAWING	SCALE 1:1	SHEET 2 OF 2
			REV A	