

Control cabinet feed-through - CUC-BH-M12A1PBK-S/R4BE - 1414396

Please be informed that the data shown in this PDF Document is generated from our Online Catalog. Please find the complete data in the user's documentation. Our General Terms of Use for Downloads are valid (<http://phoenixcontact.com/download>)



Control cabinet feed-through, M12, 8-pos., A-coded on RJ45 socket, socket input 180°, IP65/67

Why buy this product

- Compact design
- 1 Gbps
- IP65/67
- UL



Key Commercial Data

Packing unit	1 STK
GTIN	 4 055626 166766
GTIN	4055626166766

Technical data

Mechanical characteristics

Number of positions	8
Shielded	yes
Insertion/withdrawal cycles	≥ 100
Cable outlet	straight
Color	black
Mounting type	Rear mounting
Degree of protection	IP65/IP67
Type	Straight

Ambient conditions

Ambient temperature (operation)	-25 °C ... 85 °C
---------------------------------	------------------

Material data

Control cabinet feed-through - CUC-BH-M12A1PBK-S/R4BE - 1414396

Technical data

Material data

Flammability rating according to UL 94	V0
Housing material	PA
Contact material	Copper alloy

Electrical characteristics

Number of positions	8
Nominal voltage U_N	60 V
Nominal current I_N	0.5 A
Transmission characteristics (category)	CAT5 (IEC 11801:2002)
GRP transmission properties	Ethernet CAT5 (IEC 11801:2002) CAT5 (IEC 11801:2002)
Transmission speed	1 Gbps
Rated current	1.75 A
Rated voltage (III/3)	72 V (DC)

Standards and Regulations

Flammability rating according to UL 94	V0
--	----

Drawings

Dimensional drawing

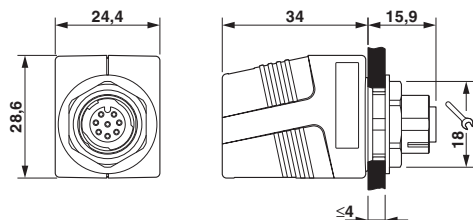

Dimensional drawing

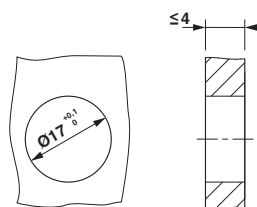

Mounting cutout

Explosion drawing

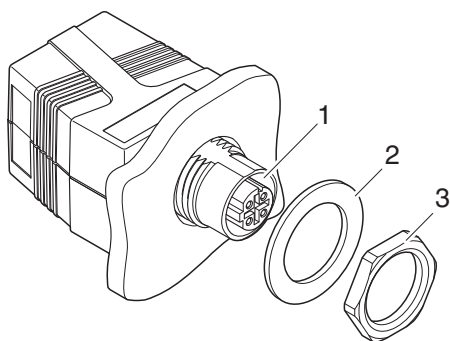

Circuit diagram

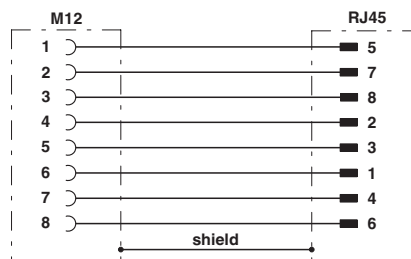

Circuit diagram

Exploded drawing

Control cabinet feed-through - CUC-BH-M12A1PBK-S/R4BE - 1414396

Approvals

Approvals

Approvals

UL Listed / cUL Listed / EAC / cULus Listed

Ex Approvals

Approval details

UL Listed		http://database.ul.com/cgi-bin/XYV/template/LISEXT/1FRAME/index.htm E335024-20140306
Nominal voltage UN		60 V
Nominal current IN		0.5 A

cUL Listed		http://database.ul.com/cgi-bin/XYV/template/LISEXT/1FRAME/index.htm E335024-20140306
Nominal voltage UN		60 V
Nominal current IN		0.5 A

EAC		B.01742
-----	---	---------

cULus Listed		
--------------	---	--

Phoenix Contact 2018 © - all rights reserved
<http://www.phoenixcontact.com>

PHOENIX CONTACT GmbH & Co. KG
 Flachsmarktstr. 8
 32825 Blomberg
 Germany
 Tel. +49 5235 300
 Fax +49 5235 3 41200
<http://www.phoenixcontact.com>