

TS2 L 7 M 26 B - K

TS2 Series

Connector Type:
L - Cable-to-Cable

Options:
K - Kit Packaging (one unit/bag)
[blank] - Bulk Packaging
Consult factory for other options

of contacts:
2-5 for #20
6-9 for #26

Gender:
M - Male (Pin)
F - Female (Socket)

Clamp Set per Cable O.D. Range for Cable-End and Cable-to-Cable only:
A - 0.110 - 0.140 [2.8 - 3.6]
B - 0.140 - 0.180 [3.6 - 4.6]
C - 0.180 - 0.216 [4.6 - 5.5]

Contact Size:
20 - 20, 22, 24, 26 AWG wires
26 - 26, 28, 30 AWG wires

Refer to TS2P SERIES drawing for Panel-mount connectors.
Refer to TS2C SERIES drawing for mating Cable-End connectors.

SPECIFICATIONS:	
MECHANICAL	
Mating / Locking Type:	Threaded Coupling
Life	5,000 cycles minimum
Operating Forces	10 lb. [44.5 N] maximum Insertion or Withdrawal
Vibration	Mil-Std 202G Method 201A
Panel-Mount Hex Nut Tongue	40 in-lb [4.5 Nm] maximum
Cable Securing System:	Threaded on metal Clamp
ELECTRICAL	
Voltage Rating	125 V AC/DC for 2-5 contact arrangements 30 V AC/DC for 6-9 contact arrangements
Current Rating	Refer to Current Carry Capacity Table
Insulation Resistance	1000 MΩ minimum
Contact Resistance	10 mΩ typical
EMI Shielding	360°
ENVIRONMENTAL	
Temperature Limits	-40°C to +135°C (-40°F to +275°F)
Operating Temperature Range	Refer to Current Carry Capacity Table
Moisture Resistance	Mil-Std 202G Method 106G
Insulation Resistance	Mil-Std 202G Method 302
Thermal Shock	Mil-Std 202G Method 107G
Salt Atmosphere (Corrosion)	Mil-Std 202G Method 101E
Ingress Protection Ratings	IP66, IP67, IP68 (6 ft. for 24 hours) per IEC60529, NEMA 250 6P
MATERIAL	
Outer Shell Metal components	Copper Alloy, electroless nickel plated
Hex Nut & Inner Metal components	Copper Alloy, nickel plated
Electrical Insulator	Medical Technology LCP, natural
Seal O-rings	Thermoplastic Elastomer
Contacts Assembly	Copper Alloy, gold plated with Stainless Steel locking clip

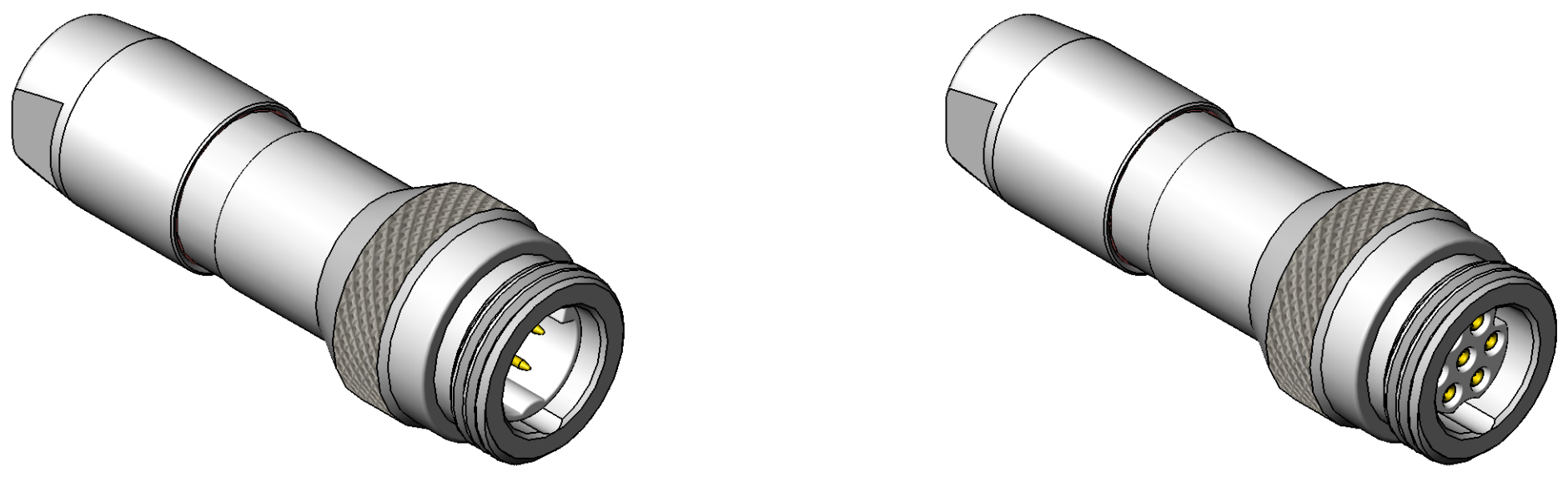

TYPICAL CABLE-TO-CABLE PIN (MALE)
(TS2L7M26B SHOWN HERE)

TYPICAL CABLE-TO-CABLE SOCKET (FEMALE)
(TS2L7F26B SHOWN HERE)

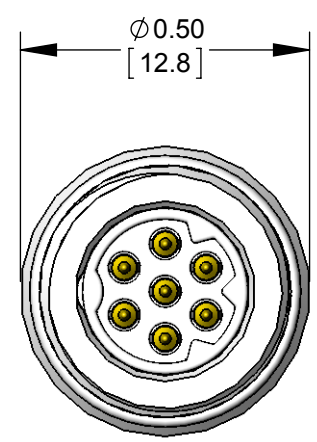

TS2L7M26B SHOWN HERE

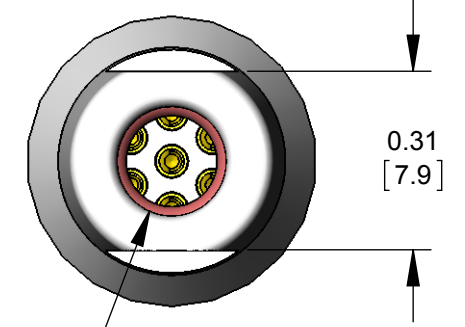
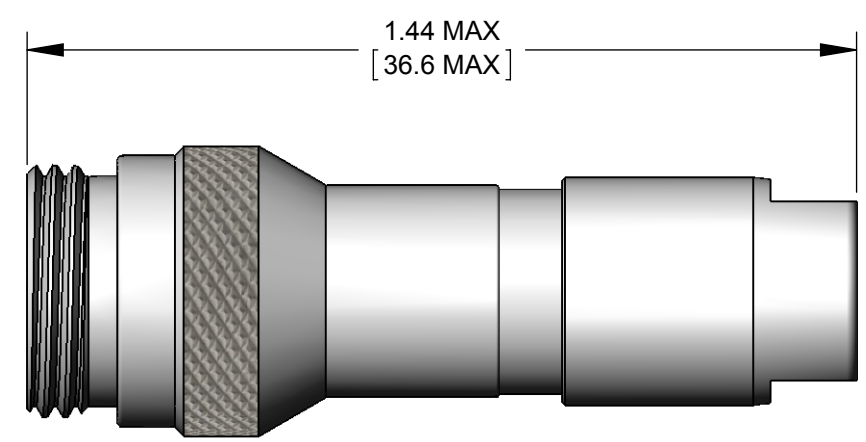

BACK NUT DIA.
SIZE A: 0.150 [3.81] DIA.
SIZE B: 0.190 [4.83] DIA.
SIZE C: 0.230 [5.84] DIA.

ALL DIMENSIONS FOR REFERENCE ONLY

Contacts	Wire (awg)	Current Rating (A) at Operating Temperature (°C)					Minimum Test Voltage (V rms)	Voltage (V rms) tested per UL2238
		45°C max.	65°C max.	85°C max.	100°C max.	110°C max.		
2 #20	20	10	9	8	7*	6	1300	125
	22	8.5	7.5	7.5	5.5*	4.5		
	24	7	6	5	4.5*	3.5		
	26	4	4	3.5	3.5*	2.5		
3 #20	20	9.5	8.5	7.5	6.5*	5		
	22	8	7	6	5*	4		
	24	6	5.5	4.5	4*	3		
	26	3.5	3.5	3	3*	2.5		
4 #20	20	9	8	7	6*	5		
	22	7.5	6.5	5.5	4.5*	3.5		
	24	5	4.5	4	3.5*	2.5		
	26	3	3	2.5	2.5*	2		
5 #20	20	8	7.5	6.5	5.5*	4.5		
	22	6.5	5.5	5	4*	3		
	24	4.5	4	3.5	3*	2.5		
	26	2.5	2.5	2	2*	1.5		
6-7 #26	26	2.5	2.5	2	2*	1.5		
	28	2	2	1.5	1.5*	1		
	30	1.5	1.5	1	1*	.5		
	26	2	2	1.5	1.5*	1		
8-9 #26	28	1.5	1.5	1	1*	.5		
	30	1	1	.5	.5*	.5		

*Temperature Rise does not exceed 30°C when tested according to UL2238. All other recommended current ratings are based on the Relative Thermal Index of the insulating material.

TOOL	TOOL TYPE	POSITIONER	CONTACT SIZE	WIRE SIZES
EN3CR	HAND CRIMP TOOL	EN2POS20	20 and 22	20 and 22 AWG
		EN3POS26	26	26, 28, and 30 AWG
EN3CRAUTO	PNEUMATIC CRIMP TOOL	EN2POS20	20 and 22	20 and 22 AWG
		EN3POS26	26	26, 28, and 30 AWG
EN2CRL	HAND CRIMP TOOL LARGE FRAME	EN2POS20L	20 and 22	20, 22, 24, and 26 AWG
EN2CRAUTOL	PNEUMATIC CRIMP TOOL LARGE FRAME			
INSTOOL20	CONTACT INSERTION	--	20	20, 22, 24, and 26 AWG
INSTOOL26		--	26	26, 28, and 30 AWG
REMT00L20	CONTACT EXTRACTION	--	20	20, 22, 24, and 26 AWG
REMT00L26		--	26	26, 28, and 30 AWG

PRELIMINARY

CUSTOMER DRAWING

THIS DRAWING DESCRIBES A DESIGN CONSIDERED PROPRIETARY IN NATURE, DEVELOPED AND MANUFACTURED BY SWITCHCRAFT INC. AND IS RELEASED ON A CONFIDENTIAL BASIS FOR IDENTIFICATION PURPOSES ONLY.

SIZE	WIDTH	MULT	LBS/M	TEMPER
UNLESS OTHERWISE SPECIFIED				
1. ALL DIMENSIONS IN INCHES [mm]				
- TWO PLACE DECIMALS ±0.02 [0.5]				
- THREE PLACE DECIMALS ±0.005 [0.13]				
DATE DRAWN	BY	CHKD	APVD	
04/20/16	PNK	04/20/16	04/20/16	
REV	ECO NUMBER	DATE	BY	APVD

DO NOT SCALE DRAWING

Switchcraft®

SHEET 1 OF 2

NAME: CABLE-TO-CABLE TS2 SERIES CONNECTOR
PART No.: TS2L SERIES
REV: 0B

REVISIONS

0B 10 lb WAS 5 lb 09/22/16 PNK SRC
0A PRELIMINARY 04/20/16 PNK SRC

SolidWorks CAD File

STEP 1

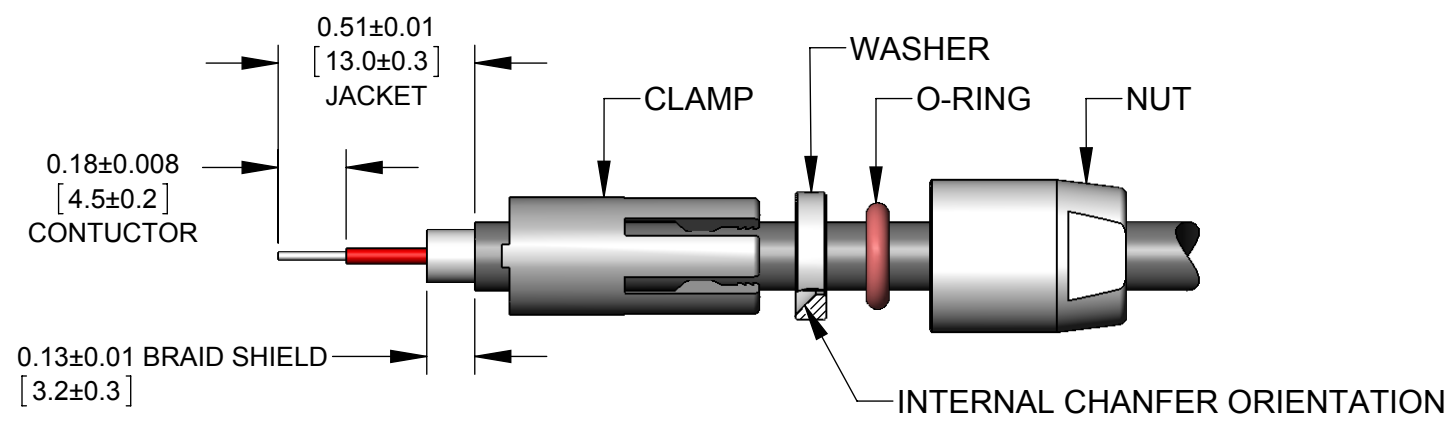

FEED THE FREE END OF CABLE THROUGH THE NUT, O-RING, WASHER, AND CLAMP IN THE ORDER SHOWN.
STRIP THE CABLE JACKET, THE CONDUCTORS, AND THE CABLE SHIELDING AS SHOWN.

STEP 2

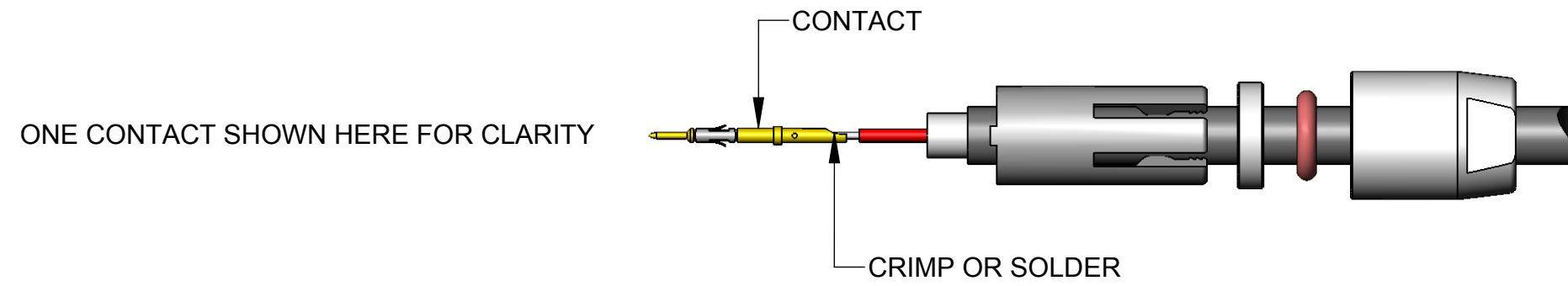

CRIMP CONDUCTORS TO CONTACTS USING HAND OR PNEUMATIC CRIMP TOOL* WITH CRIMP POSITIONER* SET PER CONTACT SIZE AND WIRE GAGE.
IF SOLDERING, IT IS RECOMMENDED TO SOLDER CONDUCTORS TO CONTACTS BEFORE INTALLATION.

STEP 3

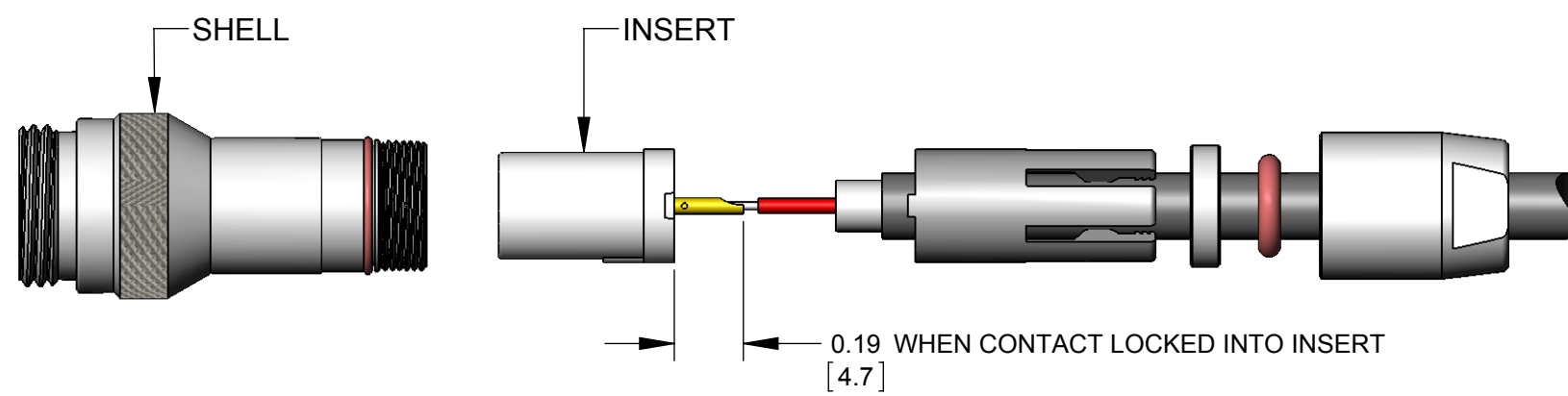

GUIDE EACH WIRED CONTACT INTO INSERT HOLE AND PUSH UNTIL CONTACT SNAPS IN PLACE. USE INSERTION TOOL* IF NECESSARY.
COLORED CONDUCTORS CAN BE ASSIGNED TO CONTACT POSITION NUMBERS AS DESIRED.
TO REMOVE A CONTACT, INSERT THE EXTRACTION TOOL* FROM THE FRONT OF INSERT AND LIGHTLY PRESS THE SPRING LOADED PLUNGER INWARD TO PUSH THE CONTACT OUT.

STEP 4

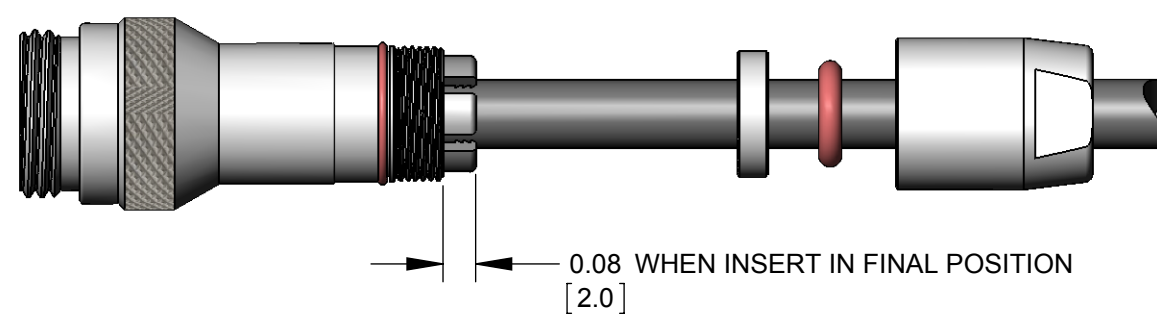

ALIGN INSERT ASSEMBLY INTO SHELL FOLLOWED BY THE CLAMP. PUSH CLAMP LIGHTLY FORWARD AND ROTATE UNTIL THE ASSEMBLY SNAPS IN THE FINAL POSITION SHOWN.

STEP 5

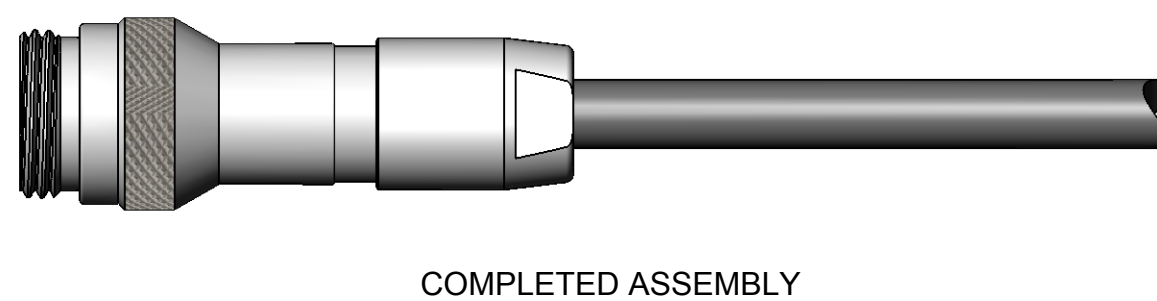

SLIDE WASHER, O-RING, AND NUT AGAINST CLAMP AND THREAD NUT ON UNTIL TIGHT - NOT TO EXCEED 9 IN-LB [1 Nm] TORQUE. A 5/16" [8mm] WRENCH CAN BE USED, IF NECESSARY.

*REFER TO TOOLS TABLE ON THIS DRAWING FOR SELECTION OF TOOLS PER CONTACT AND WIRE SIZE.

**TS2 SERIES CABLE-TO-CABLE
FIELD ASSEMBLY INSTRUCTIONS**

SCALE 2:1	Switchcraft®	
DATE DRAWN 04/20/16		
DRAWN BY PNK	PART No. TS2L SERIES_CD	REV 0A