

# CABLE ASSEMBLY INSTRUCTION

**Maple Model(s)**

HMC7000 Series

**PLC or Controller**

Allen-Bradley MicroLogix™  
1000, 1100, 1200, 1500

**Communication Type**

RS-232 with 8-pin  
Connector at PLC



**Summary**

Use this wiring diagram and illustration to assemble a communications cable for use with an Allen-Bradley MicroLogix™ 1000, 1100, 1200, or 1500 controller. The 8-pin connector for the Allen-Bradley MicroLogix™ 1000, 1100, 1200, or 1500 PLC is a special part.

**Drawing and Schematic**

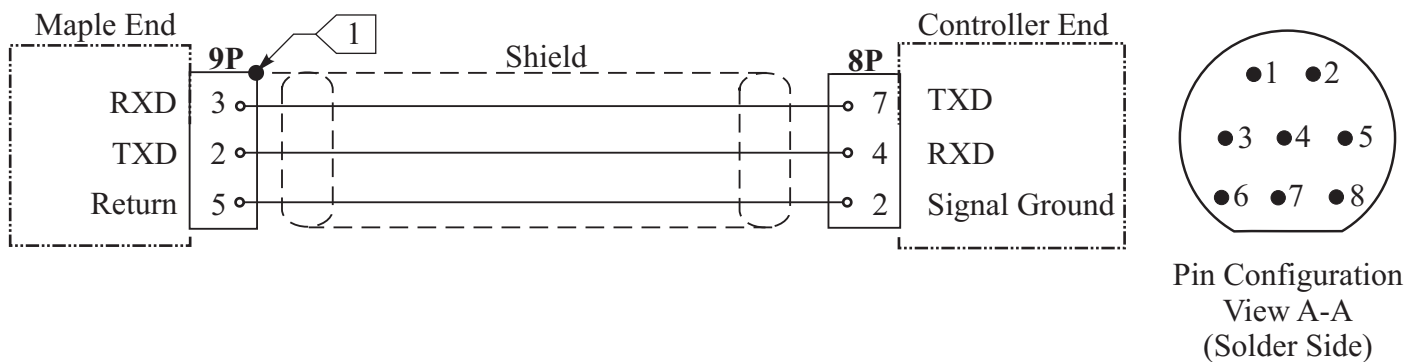
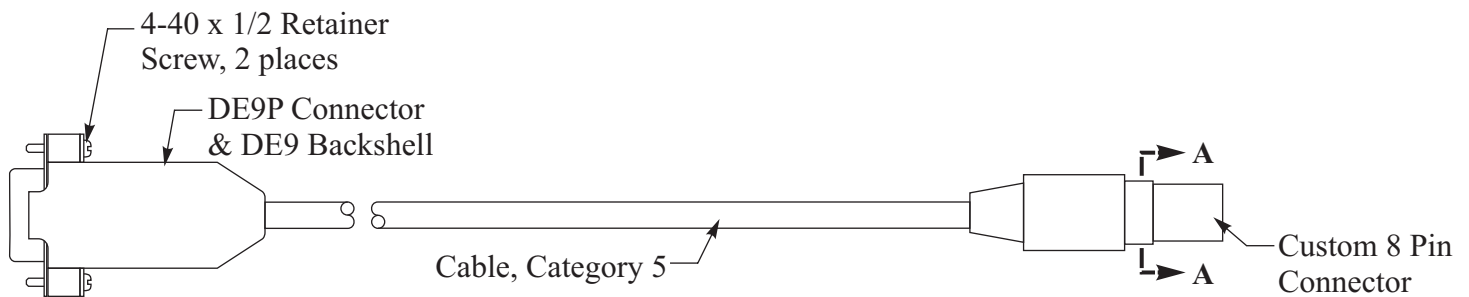

**Notes:**

- 1 Shield wire must be terminated to connector metal shell.