

3M™ 3640 Assembly Press Instructions

Instructions for the use and adjustment of the 3640 Assembly Press

General

The 3640 Assembly Press has been designed specifically for the assembly of 3M electronic connectors. All 3M Locator Plates, Applicators, Platens and Cable Cutters adapt to the 3640 Assembly Press to assist in the assembly of a wide variety of connector and harness assemblies. All of these items are purchased independently from the 3640 Assembly Press.

The 3640 Assembly Press is a manually operated portable tool that also can be fastened permanently to a work station.

Set up requires a Locator Plate which is ordered separately. Shipped with each locator plate is the appropriate Shut Height Gauge.

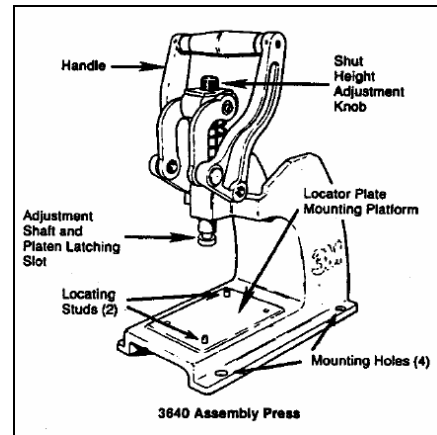

Figure 1

Procedures for Adjusting Shut Height:

Shut height settings are guidelines for proper termination depth. The adjustment settings are specified on the chart provided.

1. The shut height adjustment is made from the base of the assembly press without the locator plate or platen in place.
2. Lower the handle of the press until the handle casting makes contact with the press casting. (See Figure 3)
3. Place the shut height gauge across the press base. (See Figure 2)
4. Rotate the shut height to lower or raise adjustment feature until the bottom of the shaft contacts the desired position on the shut height gauge. (See Figure 3)
5. Install the locator plate and the appropriate platen on the press. The platen should be positioned parallel with the connector body and cover.

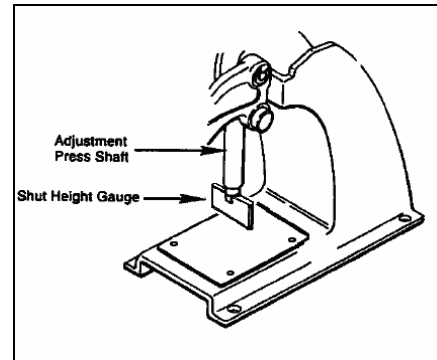

Figure 2

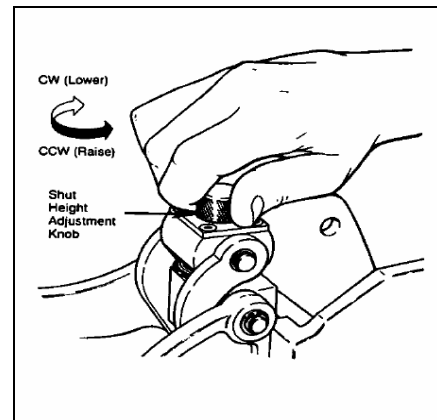

Figure 3

3M™ 3640 Assembly Press Instructions

3771 Base Plate (Optional):

The 3771 Base Plate provides additional stabilization for the 3640 Assembly Press while maintaining its portable features. It is available from your 3M distributor. (See Figure 4)

Maintenance:

The press should be kept clean and lightly oiled periodically. Use a few drops of S.A.E. 10 oil on the six pivot points and press shaft at least every 5,000 connections. It is not necessary to disassemble the press for lubrication.

Shut Height Gauge – Diagram

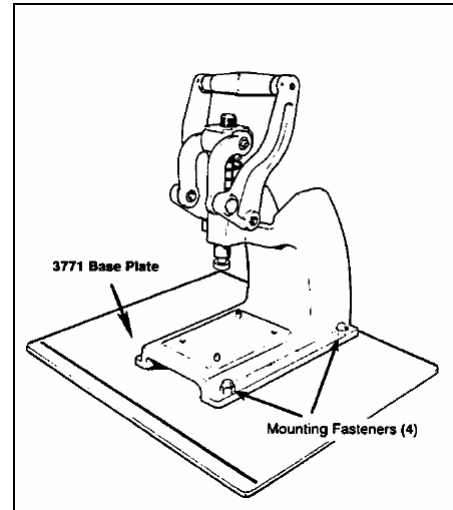
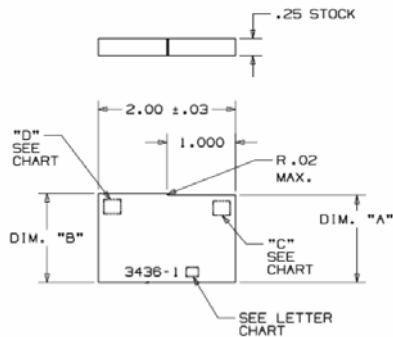

Figure 4

Shut Height Gauge - Chart

Shut Height Gauge 3436-1X	Part Number	Dim. "A"	Dim. "B"	"C"	"D"	Locator Plates 3443-XX
B	78-8118-0892-8	1.250	1.275	17	17 1/2	107N, 87, 91, 110, 100, 101M, 12, 13, 43, 71
C	78-8118-0893-6	1.425	1.450	21	21 1/2	106, 58
D	78-8118-0894-4	1.000	1.025	12	12 1/2	6, 94, 117, 125, 126
E	78-8118-0904-1	.950	.975	11	11 1/2	2, 8, 31
F	78-8118-0905-8	1.150	1.175	15	15 1/2	112, 118
G	78-8118-0906-6	1.050	1.075	13	13 1/2	20
H	78-8118-0907-4	1.275	1.300	17 1/2	18	113, 88
J	78-8118-0908-2	1.325	1.350	18 1/2	19	63
K	78-8118-0909-0	.750	.775	7	7 1/2	15, 16, 10, 47
L	78-8118-0910-8	.800	.825	8	8 1/2	33, 34
M	78-8118-0911-6	.850	.875	9	9 1/2	19
N	78-8118-0912-4	1.100	1.125	14	14 1/2	96

78-8136-3856-2_A