

Home Products Quick Quote My Parts List Site Map Contact Us



EC59 Series Oscillator

Quartz Crystal Clock Oscillators XO (SPXO) LVC MOS (CMOS) 1.8Vdc 4 Pad 2.0mm x 2.5mm Ceramic Surface Mount (SMD)



Revision G 04/02/2015

Electrical Specifications

Nominal Frequency	1.000MHz to 50.625MHz <i>Some frequencies within this range may not be available.</i>
Frequency Tolerance/Stability	(Inclusive of all conditions: Calibration Tolerance at 25°C, Frequency Stability over the Operating Temperature Range, Supply Voltage Change, Output Load Change, First Year Aging at 25°C, Shock and Vibration) ±100ppm Maximum ±50ppm Maximum ±25ppm Maximum ±20ppm Maximum
Operating Temperature Range	-10°C to +70°C -40°C to +85°C
Supply Voltage	1.8V _{DC} ±5%
Input Current	Click to Open Input Current Table
Output Voltage Logic High (V_{OH})	I _{OH} = -4mA 90% of V _{DD} Minimum
Output Voltage Logic Low (V_{OL})	I _{OL} = +4mA 10% of V _{DD} Maximum
Duty Cycle	Measured at 50% of waveform 50 ±10(%) 50 ±5(%)
Rise Time/Fall Time	Measured at 20% to 80% of Waveform 10nSec Maximum
Load Drive Capability	15pF Maximum
Output Logic Type	CMOS
Pin 1 Connection	Tri-State (High Impedance)
Tri-State Input Voltage	90% of V _{DD} Minimum or No Connection to enable output 10% of V _{DD} Maximum to disable output(High Impedance)
Standby Current	Disabled Output: High Impedance 10µA Maximum
RMS Phase Jitter	12kHz to 20MHz offset frequency 1pSec Maximum
Start Up Time	10mSec Maximum
Storage Temperature	-55°C to +125°C

Input Current

<i>Nominal Frequency Range</i>	<i>Input Current</i>
1MHz to 29.999999MHz	2.5mA Maximum
30MHz to 39.999999MHz	3.0mA Maximum
40MHz to 50.625MHz	3.5mA Maximum

Mechanical Dimensions

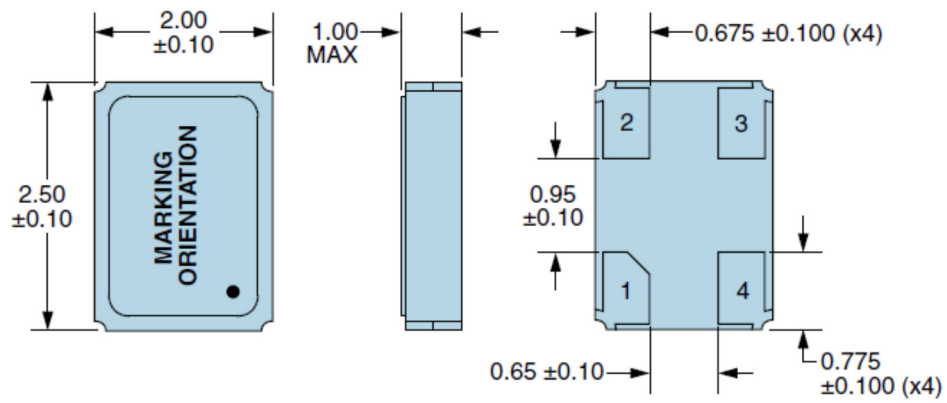

All Dimensions in Millimeters

Pin 1: Tri-State

Pin 2: Case/Ground

Pin 3: Output

Pin 4: Supply Voltage

Marking Specifications

Line 1:

EXXX

- E = Ecliptek Designator
- XXXX = Nominal Frequency in MHz (3 Digits + Decimal)

Line 2:

XXXXX

- XXXXX = Ecliptek Manufacturing Identifier

Environmental and Mechanical Specifications

ESD Susceptibility	MIL-STD-883, Method 3015, Class 1, HBM:1500V
Fine Leak Test	MIL-STD-883, Method 1014, Condition A
Flammability	UL94-V0
Gross Leak Test	MIL-STD-883, Method 1014, Condition C
Mechanical Shock	MIL-STD-883, Method 2002, Condition B
Moisture Resistance	MIL-STD-883, Method 1004
Moisture Sensitivity	J-STD-020, MSL 1
Resistance to Soldering Heat	MIL-STD-202, Method 210, Condition K
Resistance to Solvents	MIL-STD-202, Method 215
Solderability	MIL-STD-883, Method 2003
Temperature Cycling	MIL-STD-883, Method 1010, Condition B
Vibration	MIL-STD-883, Method 2007, Condition A
Thermal Resistance (θ_{JA})	39°C/W (degrees Celsius per Watt)
Thermal Resistance (θ_{JC})	13°C/W (degrees Celsius per Watt)

Tape & Reel Dimensions

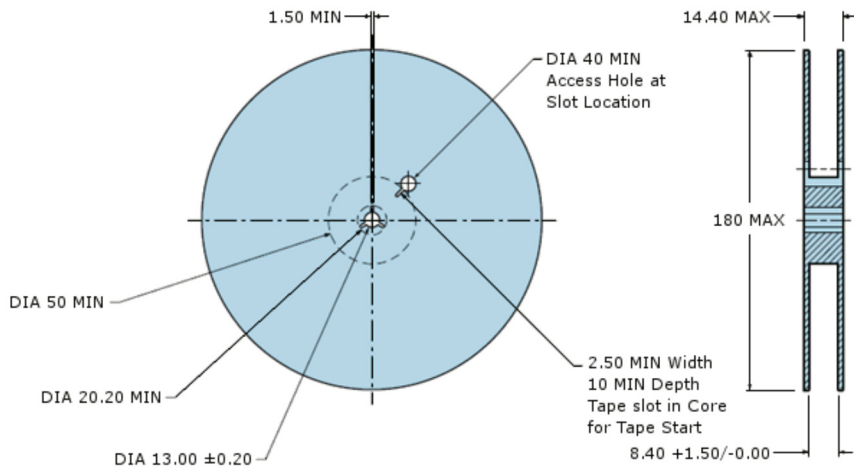
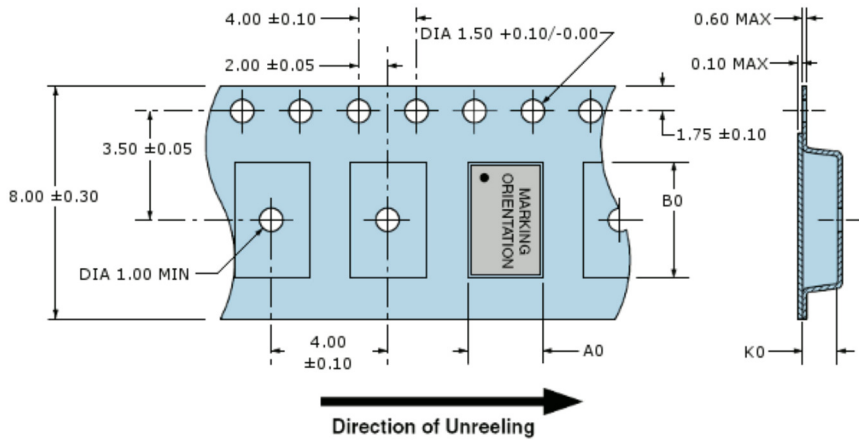

1000 pieces per reel
Compliant to EIA-481
All Dimensions in Millimeters

CMOS Test Circuit

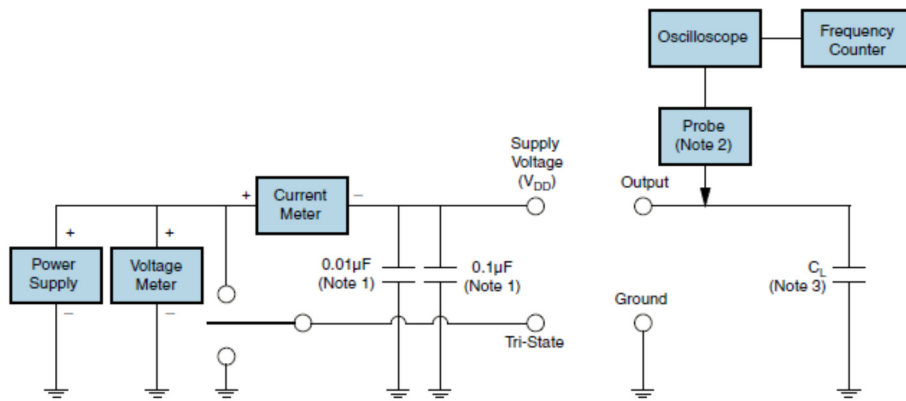

Note 1: An external 0.01µF ceramic bypass capacitor in parallel with a 0.1µF high frequency capacitor close (less than 2mm) to the package ground and supply voltage pin is required.

Note 2: A low input capacitance (<12pF), 10X Attenuation Factor, High Impedance (>10Mohms), and High bandwidth (>300MHz) passive probe is recommended.

Note 3: Capacitance value (C_L) includes sum of all probe and fixture capacitance.

Recommended Solder Pad Dimensions

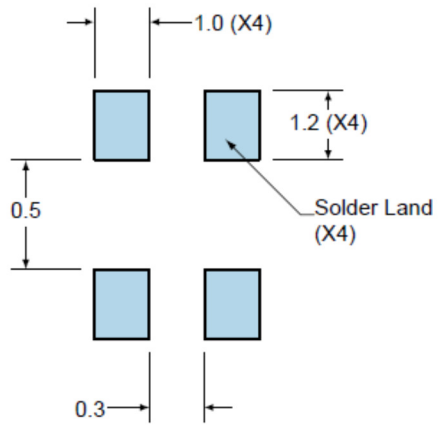

Tolerances = ± 0.1
All Dimensions in Millimeters

Solder Reflow Profile

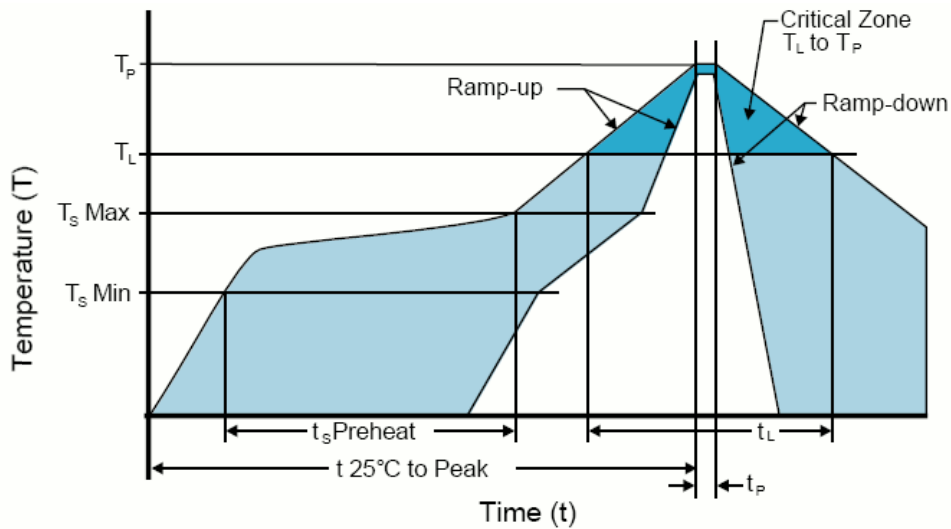

High Temperature Infrared/Convection

Note: Temperatures shown are applied to body of device.

T_S MAX to T_L (Ramp-up Rate)	3°C/second Maximum
Preheat	
- Temperature Minimum (T _S MIN)	150°C
- Temperature Typical (T _S TYP)	175°C
- Temperature Maximum (T _S MAX)	200°C
- Time (t _s)	60 - 180 Seconds
Ramp-up Rate (T_L to T_P)	3°C/second Maximum
Time Maintained Above:	
- Temperature (T _L)	217°C
- Time (t _L)	60 - 150 Seconds
Peak Temperature (T_P)	260°C Maximum for 10 Seconds Maximum
Target Peak Temperature (T_P Target)	250°C +0/-5°C
Time within 5°C of actual peak (t_p)	20 - 40 seconds
Ramp-down Rate	6°C/second Maximum
Time 25°C to Peak Temperature (t)	8 minutes Maximum
Moisture Sensitivity Level	Level 1

Low Temperature Infrared/Convection

Note: Temperatures shown are applied to body of device.

T_S MAX to T_L (Ramp-up Rate)	5°C/second Maximum
Preheat	
- Temperature Minimum (T _S MIN)	N/A
- Temperature Typical (T _S TYP)	150°C
- Temperature Maximum (T _S MAX)	N/A
- Time (t _S)	60 - 120 Seconds
Ramp-up Rate (T_L to T_P)	5°C/second Maximum
Time Maintained Above:	
- Temperature (T _L)	150°C
- Time (t _L)	200 Seconds Maximum
Peak Temperature (T_P)	240°C Maximum
Target Peak Temperature (T_P Target)	240°C Maximum 2 Times / 230°C Maximum 1 Time
Time within 5°C of actual peak (t_p)	10 seconds Maximum 2 Times / 80 seconds Maximum 1 Time
Ramp-down Rate	5°C/second Maximum
Time 25°C to Peak Temperature (t)	N/A
Moisture Sensitivity Level	Level 1

High Temperature Manual Soldering

Note: Temperatures listed are applied to body of device.
260°C Maximum for 5 seconds Maximum, 2 times Maximum.

Low Temperature Manual Soldering

Note: Temperatures listed are applied to body of device.
185°C Maximum for 10 seconds Maximum, 2 times Maximum.

Part Number Constructor

Build a Part Number

Select the parameters that meet your requirements and then click the Next button below

Frequency (MHz)

1.000 to 50.625

Some frequencies within this range may not be available

Frequency Tolerance/Stability

±100ppm Maximum

Operating Temperature Range

-10°C to +70°C

Duty Cycle

50 ±10%

Packaging Options

Tape & Reel

Next

On the next page

Part Number specific documents, resources, and tools

Part Number Specific Data Sheet

Compliance Docs
(REACH, RoHS, CMRT)

Automated Quick Quote

IPC-1752

Check Stock

My Parts List

Plus more

Part Numbering Guide

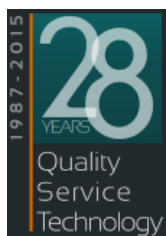
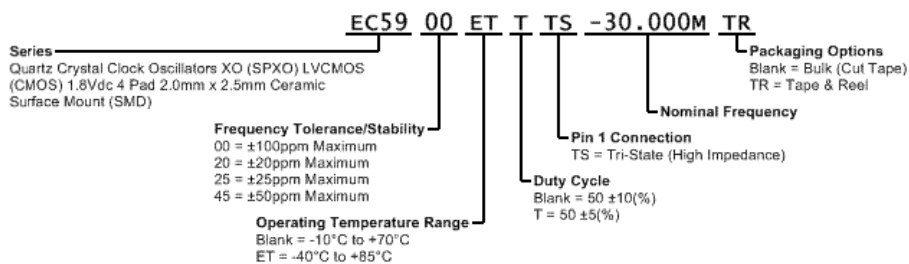

TOOLS

- Quick Quote
- SmartSearch
- Compliance Documents
- Chipset Cross Reference
- Competitor Cross Reference

PRODUCT

- Crystals
- Oscillators
- Part Search
- REACH Resources
- RoHS Resources
- End of Life

ECLIPTEK

- Authorized Distributors
- Contact
- About
- News
- Our Quality
- ISO9001
- Feedback

TERMS

- Privacy Policy
- Terms of Sale
- Legal