

Bracket-mounted Reels

SPECIFICATIONS

SPRING: High carbon steel
SPIR'ATOR spring (except ML-1548
which has power spring)

CABLE: 3/32" diameter, galvanized
steel, nylon, coated to 1/8" diameter,
126" long

CASE AND CABLE REEL: Steel, zinc
coated

MOUNTING BRACKET: Steel, zinc
coated



Part Number	Spec Number	Retraction Force (lbs)	Length (in)	Mounting Type	Cable Type
ML-1547	192395	15.0	126	Bracket	Ø3/32" galvanized steel nylon coated to Ø.125
ML-1548	192396	11.0	126	Bracket	Ø3/32" galvanized steel nylon coated to Ø.125
ML-1549	192397	8.0	126	Bracket	Ø3/32" galvanized steel nylon coated to Ø.125

Dimensions are in inches.

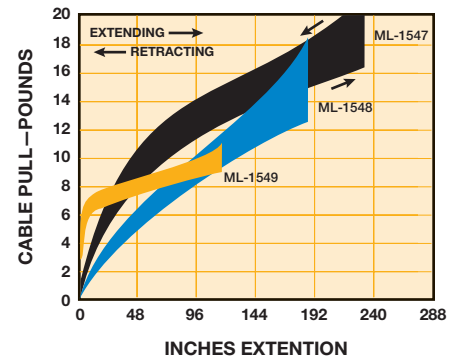
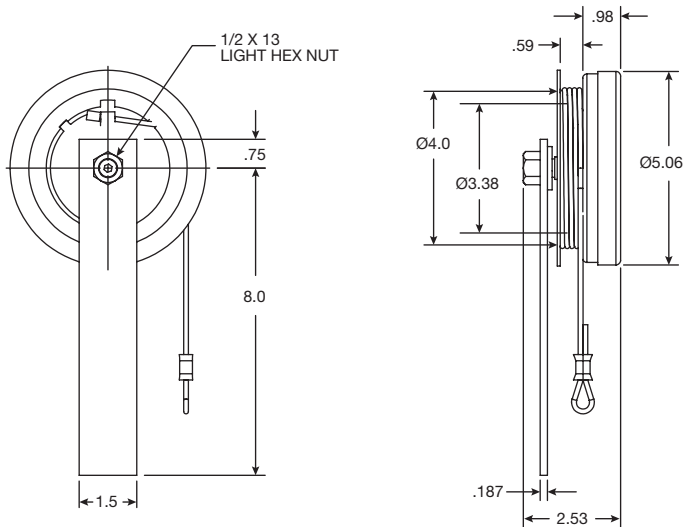

Due to the wide range of applications our products can be used in, AMETEK Hunter Spring cannot guarantee the accuracy of information or suitability of our product in any given situation due to factors beyond our control. Users of our products should perform their own tests to determine the suitability of the product for their particular purpose. Statements concerning the possible use of our products are not intended as recommendations to use our products in the infringement of any patent. Specifications subject to change without notice.

AMETEK[®]
HUNTER SPRING PRODUCTS

820 Pennsylvania Blvd. • Feasterville, PA 19053
TEL: 215-355-6900 • FAX: 215-354-1801

www.ametekhunterspring.com

ISO 9001 REGISTERED
MANUFACTURER