

FEMALE END VIEW

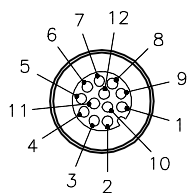

- 1 = WHITE
- 2 = BROWN
- 3 = GREEN
- 4 = YELLOW
- 5 = GRAY
- 6 = PINK
- 7 = BLUE
- 8 = RED
- 9 = ORANGE
- 10 = TAN
- 11 = BLACK
- 12 = VIOLET



SPECIFICATIONS

CONTACT CARRIER MATERIAL	NYLON OR TPU
CONTACT MATERIAL/PLATING	BRASS/GOLD
HOUSING MATERIAL/FINISH	STAINLESS STEEL/PASSIVATED
O-RING MATERIAL	NITRILE
RATED CURRENT [A]	2.0 A
RATED VOLTAGE [V]	60 VAC/75 VDC
OUTER CABLE JACKET MATERIAL/COLOR	PVC/BLACK
CONDUCTOR INSULATION MATERIAL	PVC
NUMBER OF CONDUCTORS [AWG]	12x24 AWG
DRAIN/SHIELD	26 AWG DRAIN/ALUMINUM FOIL SHIELD
TEMPERATURE RATING	-40°C to +105°C (-40°F to +221°F)
PROTECTION CLASS	MEETS NEMA 1,3,4,6P AND IEC IP68

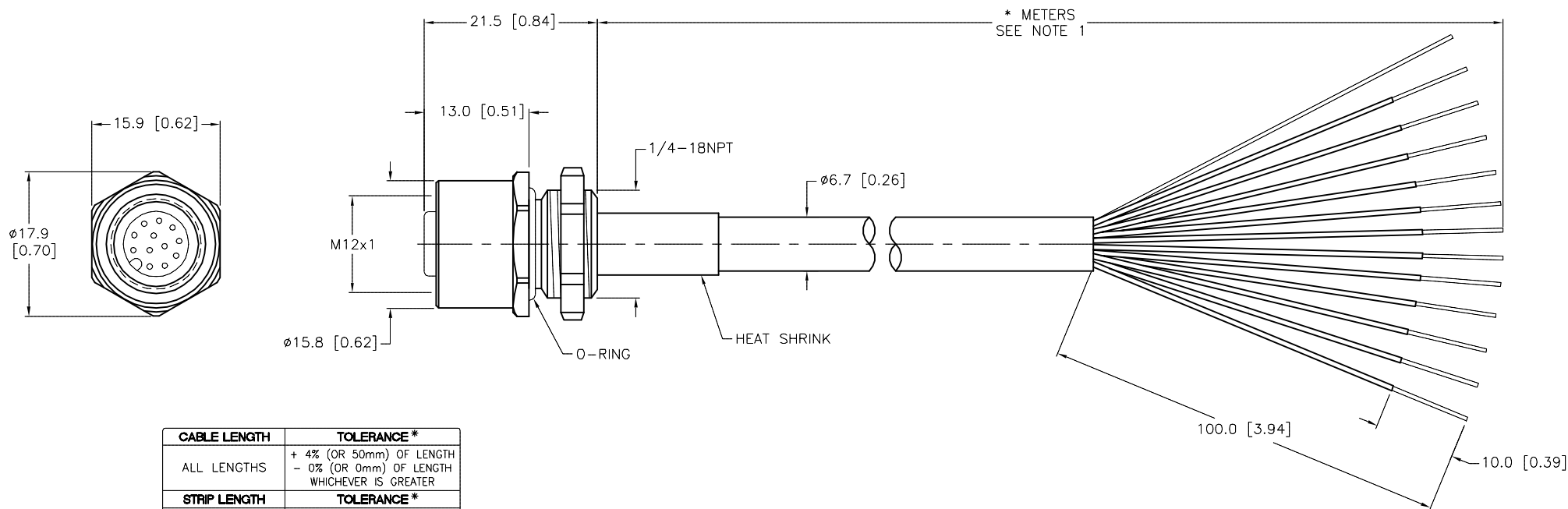

CABLE LENGTH	TOLERANCE*
ALL LENGTHS	+ 4% (OR 50mm) OF LENGTH - 0% (OR 0mm) OF LENGTH WHICHEVER IS GREATER
STRIP LENGTH	TOLERANCE*
0-7mm	±0.5mm
8-29mm	±1.0mm
30-49mm	±2.0mm
50-69mm	±3.0mm
70-100mm	±4.0mm
OVER 100mm	±5.0mm

* UNLESS OTHERWISE SPECIFIED

SOURCE DRAWING - FOR REFERENCE ONLY

NOTES:

- "*" INDICATES LEAD LENGTH IN METERS. CONTACT TURCK TO ORDER SPECIFIC LENGTHS.
- "/S618" DESIGNATES FOIL SHIELD AND DRAIN WIRE, DRAIN NOT CONNECTED.

RELATED DOCUMENTS	3RD ANGLE PROJECTION	THIS DRAWING IS CONFIDENTIAL AND THE PROPERTY OF TURCK INC. USE OF THIS DOCUMENT WITHOUT WRITTEN PERMISSION IS PROHIBITED.		3000 CAMPUS DRIVE MINNEAPOLIS, MN 55441 1-800-544-7769 (763) 553-7300 (763) 553-0708 fax turck.com	
1.		DRFT	DJW	DATE	05/03/07
2.		APVD		SCALE	1=.8
3.	ALL DIMENSIONS DISPLAYED ON THIS DRAWING ARE FOR REFERENCE ONLY	UNIT OF MEASUREMENT			DESCRIPTION
4.		MILLIMETER [INCH]			FKV 12-*/18.25/S618
MATERIAL	CONTACT TURCK FOR MORE INFORMATION	IDENTIFICATION NO.			REV
SEE SPECIFICATIONS					E
FINISH		DO NOT SCALE THIS DRAWING			FILE: 777016917
SEE SPECIFICATIONS		SHEET 1 OF 1			

E	ADD RECEPTACLE ENDVIEW PER ECO	TV	01/21/16	53190
REV	DESCRIPTION	BY	DATE	ECO NO.