

EM30-AP6X2-H1141/S1102

Signal Processor – For Inductive Sensor up to 250 °C

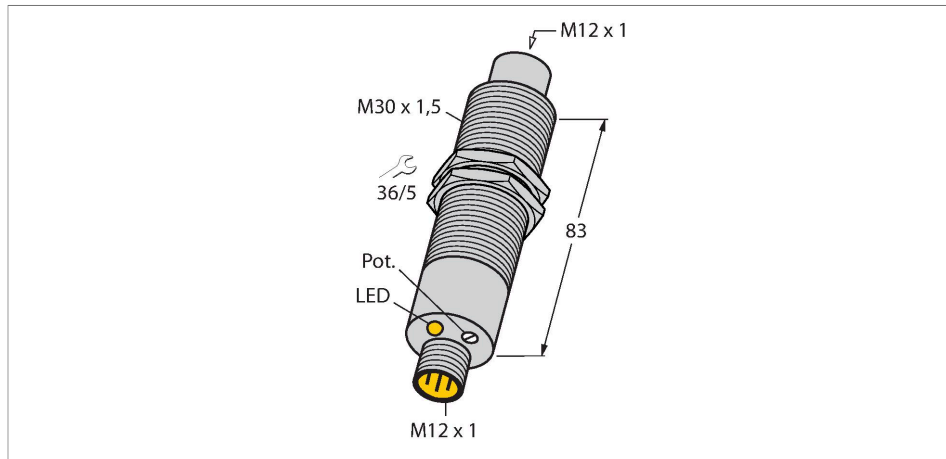

Features

- Threaded barrel, M30 x 1.5
- Stainless steel, 1.4571
- For temperatures up to +70 °C
- Functions only with Ni25-CQ40...and Ni40-CQ80...
- DC 3-wire, 10...30 VDC
- NO contact, PNP output
- M12 x 1 male connector

Wiring diagram

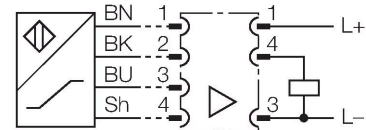

Technical data

Type	EM30-AP6X2-H1141/S1102
ID	1602411
General data	
	switch point adjustable via potentiometer
Repeat accuracy	≤ 2 % of full scale
Temperature drift	≤ ±20 %
Hysteresis	3...15 %
Electrical data	
Operating voltage	10...30 VDC
DC rated operational current	≤ 200 mA
No-load current	15 mA
Residual current	≤ 0.1 mA
Isolation test voltage	≤ 0.5 kV
Short-circuit protection	yes / Cyclic
Voltage drop at I _o	≤ 1.8 V
Wire breakage/Reverse polarity protection	yes / Complete
Output function	3-wire, NO contact, PNP
Switching frequency	0.04 kHz
Mechanical data	
Design	Threaded barrel, M30 × 1.5
Dimensions	83 mm
Housing material	Metal, 1.4571 (AISI 316Ti)
End cap	Metal, 1.4571 (AISI 316Ti)
Max. tightening torque of housing nut	40 Nm

Functional principle

The sensors must be operated with an EM30-AP6X2-H1141/S1102 signal processor. The switching distance is set using a potentiometer (continuous) on the signal processor. This is located under a cover screw next to the LED. Where possible, the switching distance must be set at operating temperature. When setting the switching distance at room temperature, the temperature sensitivity of the sensor system must be taken into account.

Setting:

1. Place the target (steel, min. 1 mm thick, square, edge length min. 3x rated switching distance) at a safe switching distance in front of the sensor
2. Turn the potentiometer counterclockwise until the LED lights up green
3. Turn the potentiometer clockwise until the LED lights up yellow
4. Perform functional checks in the operating state

Technical data

Electrical connection	Connector, M12 × 1
Environmental conditions	
Ambient temperature	-20...+70 °C
Vibration resistance	55 Hz (1 mm)
Shock resistance	30 g (11 ms)
Protection class	IP67
MTTF	758 years acc. to SN 29500 (Ed. 99) 40 °C
Power-on indication	LED, Green
Switching state	LED, Yellow

Accessories

MW-30	6945005
-------	---------

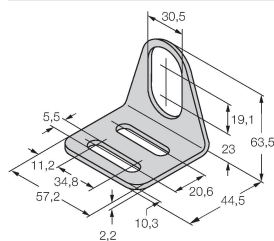

Mounting bracket for threaded barrel sensors; material: Stainless steel A2 1.4301 (AISI 304)

Wiring accessories

Dimension drawing	Type	ID	
	RKH4-2/TFE	6935482	Connection cable, M12 female, straight, 3-pin, stainless steel coupling nut, cable length: 2 m, jacket material: PVC, gray temperature range -25...+80 °C; other cable lengths and designs available, see www.turck.com
	RKH4-2/TFG	6934384	Connection cable, M12 female, straight, 3-pin, stainless steel coupling nut, cable length: 2 m, jacket material: TPE, gray temperature range -40...+105 °C; other cable lengths and designs available, see www.turck.com