

Catalog Number  
**P2030B1150CU**  
**P2030L1150CU**

Enclosure  
**Type 1**

RATINGS: 150A MAXIMUM - SEE MAIN BREAKER RATING IF USED.  
 BACK-FED BREAKER REQUIRES HOLD-DOWN MEANS.  
 120/240 V~, 60 HZ, 1Ø 3W  
 208Y/120 V~, 60 HZ, 1Ø 3W

FOR INSTALLATION BY A QUALIFIED PERSON IN ACCORDANCE WITH ALL LOCAL ELECTRICAL CODES AND/OR THE NATIONAL ELECTRICAL CODE ®.

**SUITABLE FOR USE AS SERVICE EQUIPMENT WHEN MAIN BREAKER IS INSTALLED.** WHEN USED AS SERVICE EQUIPMENT, APPLY "SERVICE DISCONNECT" LABEL TO FRONT NEXT TO MAIN BREAKER HANDLE.

WHEN USED AS SERVICE EQUIPMENT, UNUSED NEUTRAL BAR TERMINALS MAY BE USED TO TERMINATE EQUIPMENT GROUNDING WIRES IN THE COMBINATIONS INDICATED FOR EQUIPMENT GROUND BAR TERMINALS.

IF THE NEUTRAL TIE STRAP IS REMOVED, LUG KIT ECLKB1 MUST BE INSTALLED AND BONDED. THE LEFT NEUTRAL BAR WILL BECOME THE EQUIPMENT GROUND.

SUM OF QT BREAKER RATING IS NOT TO EXCEED 110 AMPS PER BRANCH CIRCUIT BUS STAB.

TO RESET BREAKERS WITH TRIPPED HANDLE POSITION BETWEEN "ON" AND "OFF", MOVE HANDLE TO "OFF" THEN TO "ON".

REMOVE TWISTOUTS FROM TRIM ONLY WHERE BREAKERS WILL BE INSTALLED. ALL OPENINGS MUST BE FILLED WITH BREAKERS OR FILLER PLATES. USE TWO QF3 FILLER PLATES TO FILL 150-225A MAIN BREAKER OPENING.

THIS LOAD CENTER IS INVERTIBLE FOR BOTTOM FEED APPLICATIONS.

Siemens Industry, Inc. Norcross, Georgia U.S.A.

**J2**

40900309 0101 Rev.00

**IMPORTANT:** DO NOT ALLOW PETROLEUM BASED (HYDROCARBON) SPRAYS, CHEMICALS, SOLVENTS OR ANY PAINT TO CONTACT INTERIOR COMPONENTS. PETROLEUM BASED CHEMICALS CAN CAUSE DEGRADATION OF ELECTRICAL INSULATING MATERIALS.

**⚠ DANGER**

**Hazardous Voltage.**  
 Will cause death, serious injury or substantial property damage.

Turn off power supplying this equipment before working inside.

**⚠ PELIGRO**

**Voltaje peligroso. Causará la muerte, lesiones graves o daño substancial a la propiedad.**

Desconecte el suministro de energía a este equipo antes de trabajar en su interior.

**USE COPPER OR ALUMINUM 60°/75°C WIRE**  
 SEE BREAKER MARKINGS FOR WIRE SIZE AND TORQUE REQUIREMENTS.

TERMINALS	WIRE	TORQUE
A, B	300 kcmil - 4 AWG	275 LB-INS
N	4/0-4 AWG CU; 300kcmil-4 AWG AL	275 LB-INS
G	2/0-4 AWG	110 LB-INS
MAIN BREAKER	1/0 AWG CU; 3/0 AWG AL MAX.	See Breaker
NEUTRAL/GROUND BARS (USE TYPE EC2GB or EC3GB GND BAR KIT ACCESSORY)	10-14 CU/10-12 AL 8 AWG 6-4 AWG	20 LB-INS 25 LB-INS 35 LB-INS
GROUND CONDUCTORS ONLY	(2)or(3) 14 AWG (2) 12-10 AWG	20 LB-INS 20 LB-INS
ECLK1-2 NEUTRAL LUG KIT	2/0-2 AWG	45 LB-INS
ECLK2 NEUTRAL LUG KIT	2/0-4 AWG	135 LB-INS
ECLK3 NEUTRAL LUG KIT	300 kcmil - 1 AWG	340 LB-INS
MAIN LUG/MAIN BRKR TO BUS CONNECTION (1/4-20 NUT)		45 LB-INS
BONDING SCREW		45 LB-INS

ACCESSORIES	
DESCRIPTION	CAT. NO.
DOOR LOCK	ECQFL2
FILLER PLATE, 1"	QF3
QP BREAKER HOLD-DOWN	ECMBR2
QNR LINE TERMINAL BARRIER	ECLTB3
BONDABLE GROUND LUG	ECLKB1
SUBFEED LUG KIT	ECLK2125
STANDBY PWR INTERLOCK KITS: ECSBPK01, ECSBPK02, ECSBPK03, ECSBPK05, ECSBPK06, ECSBPK07	

MAIN LUG / MAIN BREAKER KITS	
USE APPROPRIATE KIT FROM CHART BELOW TO CONVERT PANEL	
DESCRIPTION	CAT. NO.
150 AMP MAIN BREAKER	MBK150A
150-225 AMP MAIN LUG	ECMLK225

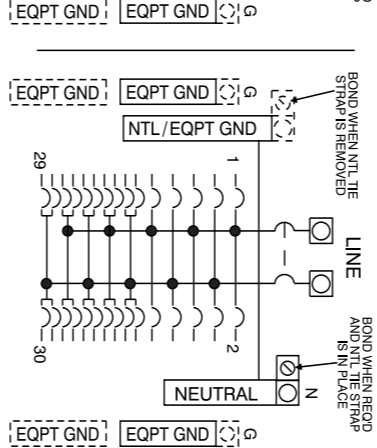
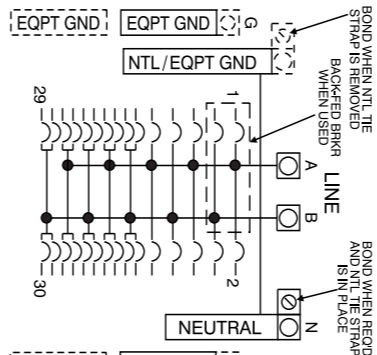

Assembled in Mexico  
 © 2017 Copyright Siemens Industry, Inc.  
 ® The National Electrical Code is a registered trademark of the National Fire Protection Association.

**SHORT CIRCUIT CURRENT RATING** THIS PANELBOARD HAS A MAXIMUM SHORT CIRCUIT CURRENT RATING OF 100,000 AMPS RMS SYMMETRICAL, 120/240V~, THE ACTUAL RATING IS DEPENDENT ON THE BRANCH BREAKERS INSTALLED IN THIS PANELBOARD AND THE MAIN/FEEDER BREAKER. IF ANY, INSTALLED AHEAD OF THIS PANELBOARD. THE CORRECT MAIN BREAKER/FEEDER/MAIN BREAKER/BRANCH BREAKER SERIES COMBINATIONS TO BE USED ARE LISTED IN THE TABULATION BELOW. ANY CIRCUIT BREAKER INSTALLED, REPLACED, OR ADDED IN THIS PANELBOARD MUST BE MANUFACTURED BY SIEMENS AND MUST BE OF THE CORRECT TYPE AS INDICATED IN THE TABULATION BELOW. USE OF OTHER CIRCUIT BREAKERS IN THIS EQUIPMENT MAY VOID THE WARRANTY.

MAIN BREAKER	MAIN/FEEDER BREAKER	PANELBOARD MAIN	BRANCH BREAKER	RATING AMPS
NONE USED	NONE USED	NONE USED or QP, QNR	QP, QG, QT, QAF, QAF2, QPF, QE, QNR	10,000
	NONE USED	NONE USED	QPH, QAFH, QAF2H, QPHF, QEH, QNRH	22,000
	NONE USED	EQ8693, QPH, QNRH	QP, QT, QAF, QAF2, QPF, QE, QNR	
	QSHH	NONE USED or EQ8693, QP, QPH, QNR, QNRH	QP, QPH, QT, QAF, QAFH, QAF2, QAF2H, QPF, QPHF, QE, QEH, QNR, QNRH	42,000
NONE USED	NONE USED	HQP, HQAF2, HQNR	65,000	
ED4, ED6, HQP, HBL, HQS, HQN, HQPP	NONE USED or EQ8693, QP, QPH, HQP, QNR, QNRH, HQNR	QP, QPH, QT, QAF, QAFH, QAF2, QAF2H, QPF, QPHF, QE, QEH, QNR, QNRH		
Siemens Breaker Types NDGA, NFGA				QPH, BLH
Siemens Breaker Types JXD2(-A), JD6(-A), JXD6(-A), LD6(-A), LXD6(-A), MD6, MXD6, ND6, NXD6, NJJA, NJGA, NLGA, NLGB, NMG, NNG, NPG, PD6, PXD6, RD6, RXD6	QPH, BLH, QS, QN			
Siemens Breaker Types ND6, FXD6	NONE USED or QP, BL, QS, QN, QJ2			
Siemens Breaker Types ND6, NXD6, or Class J, T, R, or L Fuses	QPH, BLH, QN			
Siemens Breaker Types JXD2(-A), JD6(-A), JXD6(-A), LD6(-A), LXD6(-A), MD6, MXD6, ND6, NXD6, PD6, PXD6, RD6, RXD6, NDGA, NFGA, NJJA, NJGA, NLGA, NLGB, NMG, NNG, NPG	NONE USED	QPH, HQP, QNR, QNRH, HQNR		
Siemens Breaker Types JXD2(-A), JD6(-A), JXD6(-A), LD6(-A), LXD6(-A)	QJH2			
NONE USED	HQSH, HQPPH, HQJ2H, HED4, HED6, NGB			
Siemens Breaker Types HFD6, HFxD6, HFGA, HJD6(-A), HJXD6(-A), HJGA, HLD6(-A), HLXD6(-A), HLGA, HLGB, HMD6, HMxD6, HMG, HND6, HNXD6, HNG, HPD6, HPXD6, HPG, HRD6, HRXD6, or Class J, T, R, or L Fuses	ED4, ED6, QS	NONE USED or EQ8693, QP, QPH, HQP	QP, QPH, HQP, QT, QAF, QAFH, QAF2, QAF2H, HQAF2, QPF, QPHF, QE, QEH	100,000
Siemens Breaker Types HFD6, HFxD6, or 300V Class T Fuses - 200A Max	NONE USED or QP, BL			
Siemens Breaker Types HDGA, HFGA, or 300V Class T Fuses - 600A Max	NONE USED or QPH, BLH	NONE USED or QPH, HQP	QPH, HQP	

C150b-RevA