

Digital, Dual-Element Pyros For Motion Sensing

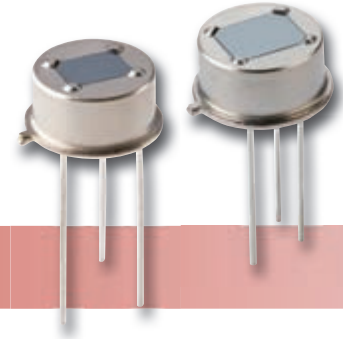

PYD 1788, PYD 1798 – DigiPyro®

Target Applications

- Passive Intrusion Alarms
- Auto Light Switch
- Auto Lamps

Features and Benefits

- TO-5 metal housing
- Digital Direct Link
- Different window sizes
- Excellent EMI protection

Product Description

The DigiPyro® detector range in TO-5 housing includes many Dual-Element types, some with different window sizes. The element configurations are identical, along with the internal electronic circuits. The PYD 1788 is the lower-cost version with standard size window, while PYD 1798 offers better White-Light-Immunity (WLI) performance and Field of View. Both the PYD 1788 and PYD1798 models include a built-in temperature reference. The Output signals are communicated in one digital bit stream of 2x14 bit, output via a single wire "Direct Link" connection to a suitable host microprocessor. With PYD 1784 we also offer an electrically equivalent to PYD1788, but in TO49 housing.

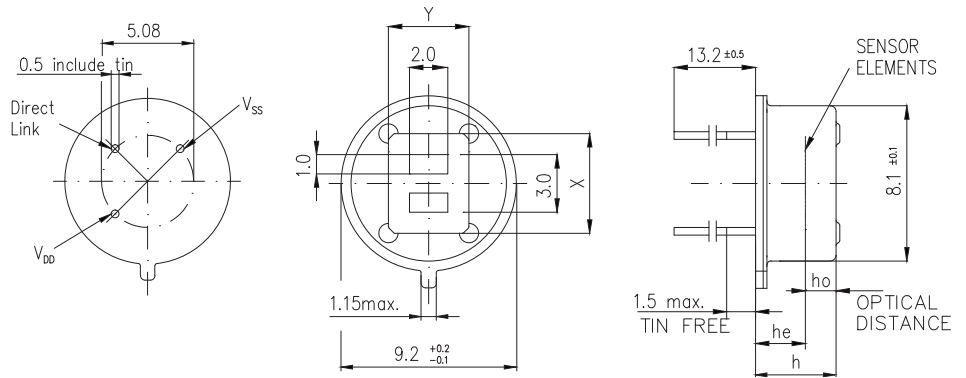
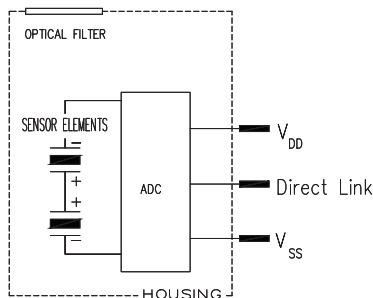

PYD 1798 and PYD 1788

Parameter	Symbol	PYD 1798	PYD 1788	Unit	Remarks
Responsivity, min.	R_{min}	3,3	3,3	kV/W	$f = 1 \text{ Hz}$
Responsivity, typ.	R	4	4	kV/W	$f = 1 \text{ Hz}$
Match, max.	M_{max}	10	10	%	
Noise	N, N_{max}	78/20	78/20	μV_{pp}	
Field of View, vertical	FoV	110°	95°		unobstructed
Field of View, horizontal	FoV	110°	90°		unobstructed
WLI		***	**		Excelitas test set up
Height	h	4,2	4,2	mm	
Optical Element Location	he/ho	3,1 / 0,7	3,1 / 0,7	mm	
Filter Size	X / Y	5,2 / 4,2	4,6 / 3,4	mm	
Digital Data					
Operating Voltage	V_{DD}	2,7...3,6	2,7...3,6	V	
Supply Current	I_{DD}	10	10	μA	$V_{DD}=3,3V$
	I_{DDmax}	15	15	μA	$V_{DD}=3,3V$
Sample Time	t_{SMPL}	2	2	ms	min.
ADC Resolution		14	14	Bits	
Output Data Format		2 x 14	2 x 14	Bits	MSB first
ADC Sensitivity		6...7	6...7	$\mu V/count$	
ADC Output Offset		7000...9200	7000...9200	counts	
ADC Output Offset, typ.		8192	8192	counts	