

BIS C-122-11/L BIS0015

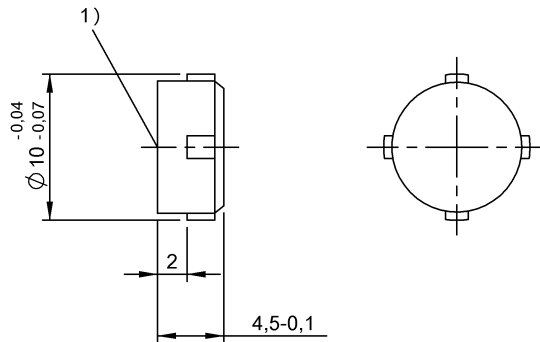

1) Sensing surface



Electrical data

Memory capacity	2047 Byte
Memory organization	64 × 8 bits
Programming cycles	up to 30 °C: 1,000,000 up to 70 °C: 500,000
Programming time	for 1x8 bits: 0.45s for 64x8 bits: 1.1s
Read cycles	Unlimited
Read time	for 64x8 bits: 0.33 s

Environmental conditions

Ambient temperature	-30...70 °C
EN 60068-2-27, Continuous shock load	yes
EN 60068-2-27, Shock	yes
EN 60068-2-6, Vibration	yes
Protection type IEC 60529	IP68
Storage temperature	-30...85 °C
Storage temperature temporary	120 °C

Functional safety

EN 60068-2-32 Free fall	yes
-------------------------	-----

General data

Antenna type	round
Approval/Conformity	CE UL-FILE E227256, Vol.X1, BIS EN 55011
	Size 1, Cl. A

Material

Housing material	Epoxy-resin/fiberglass
------------------	------------------------

Mechanical data

Application weight	0.70 g
Dimension	Ø 10 x 4.5 mm
Installation	for flush mounting (in steel)

Remarks

Only together with converter BIS C-901 or BIS C-6xx and the appropriate read/write head.
 Values are under rated conditions unless otherwise specified.
 For installation requirements see corresponding read/write head.
 Time specification includes data check.
 IP68 tested according to BWN Pr 36
 On the last page only 63x8 bits are usable.
 For installation in hole Ø10 H11 (glue)