

# MODEL 153

## Reverse Phase Relay

- Senses phase reversal on Wye or Delta
- 190 to 500 VAC range
- DIN Rail Mount or Surface-mount
- Low power consumption



### DESCRIPTION

The **Model 153 Reverse Phase Relay** is designed to continuously monitor phase rotation of 3-phase lines. This device should be used in applications where proper phase rotation is critical, such as fan motors, compressors, grinders, elevators, etc.

The solid-state sensing circuit drives an internal electromechanical relay which energizes when power, *with correct phase rotation*, is applied.

The relay will not energize if the applied phases are reversed. It will de-energize if phase rotation is reversed while the motor is running. An LED indicator will illuminate with correct A B C phase rotation.

### SPECIFICATIONS

Model	153
Nominal voltage	190-500 VAC (phase to phase)
Frequency	50 to 60Hz
Power Consumption	2W per phase
Transient protection	2500 VRMS for 10ms
Repeat accuracy	± 0.1 % (fixed conditions)
Response time	.05 seconds
Reset time	.05 seconds
Reset type	Automatic
Dead band	Approximately 2%
Output contacts	SPDT 10A at 240VAC resistive
Expected relay life	Mechanical: 10 million operations Electrical: 100,000 at rated load
Operating temp	- 20° to +131° F
Humidity tolerance	0-97% w/o condensation
Case material	ABS plastic
Mounting	DIN Rail or Surface Mount
Weight	4 oz.

### DIMENSIONS

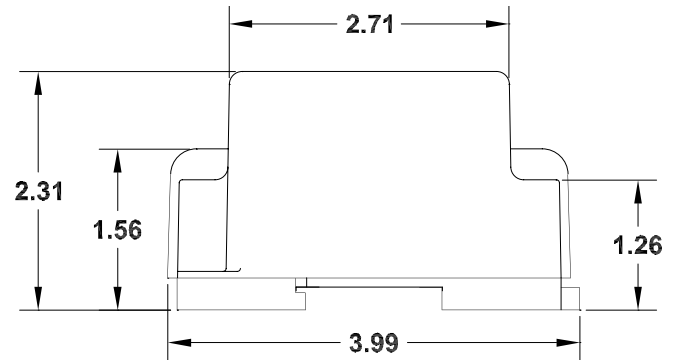
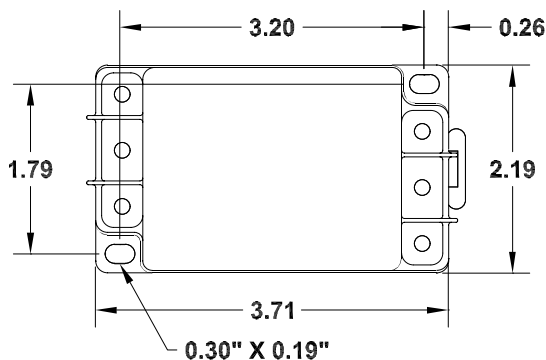

Telephone: Main - (918) 438-1220  
Sales - (800) 862-2875  
Fax: (918) 437-7584

E-mail: sales@time-mark.com  
Internet: http://www.time-mark.com



11440 East Pine Street  
Tulsa, Oklahoma 74116

06/2015  
© 2015 TIME MARK CORPORATION

TIME MARK is a division of  AEMT, Inc.

# MODEL 153 Reverse Phase Relay

READ ALL INSTRUCTIONS BEFORE INSTALLING, OPERATING OR SERVICING THIS DEVICE.  
KEEP THIS DATA SHEET FOR FUTURE REFERENCE.

## GENERAL SAFETY

POTENTIALLY HAZARDOUS VOLTAGES ARE PRESENT AT THE TERMINALS OF THE MODEL 153.  
ALL ELECTRICAL POWER SHOULD BE REMOVED WHEN CONNECTING OR DISCONNECTING WIRING.  
THIS DEVICE SHOULD BE INSTALLED AND SERVICED BY QUALIFIED PERSONNEL.

## Installation Instructions

### INSTALLATION

Mount the Model 153 in the desired location.

Connect the 3-phase power to the terminals marked **A**, **B**, and **C**.

Connect the control circuit to the terminals with the contact markings. Refer to the Typical Application wiring diagram for additional information.

If the relay contacts do not transfer when power is applied (LED indicator-Off), check that all three voltages are correct.

If power is present and the voltage is correct, remove power. Reverse two of the three phase connections. Re-apply power.

The contacts should transfer to the normal condition (normally open contacts closed; LED indicator-On). Calibrations or adjustments are not required.

### TROUBLESHOOTING

Should the relay fail to operate properly, check that all three voltages are present and are of the correct level. Check all fuses and verify that all wiring connections are correct. Should problems persist, contact the factory for assistance.

### TYPICAL APPLICATION

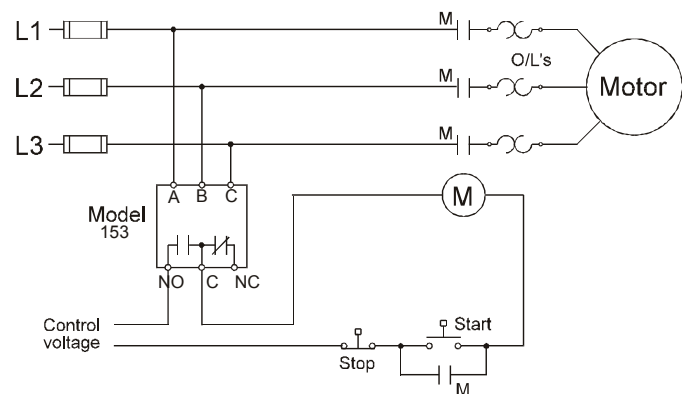

### WARRANTY

This product is warranted to be free from defects in materials and workmanship, and is covered by our exclusive **5-year Unconditional Warranty**. Should this device fail to operate for any reason, we will repair it for five years from the date of manufacture. For complete warranty details, see the *Terms and Conditions of Sales* page in the front section of the Time Mark catalog or contact Time Mark at 1-800-862-2875.

Telephone: Main - (918) 438-1220  
Sales - (800) 862-2875  
Fax: (918) 437-7584

E-mail: sales@time-mark.com  
Internet: http://www.time-mark.com



**TIME MARK**  
CORPORATION

11440 East Pine Street  
Tulsa, Oklahoma 74116

06/2015

© 2015 TIME MARK CORPORATION

TIME MARK is a division of  AEMT, Inc.