

FEMALE END VIEW	PANEL CUTOUT (TYPICAL)	SPECIFICATIONS	
 <p>1 = WHITE/BLACK 2 = BLACK 3 = WHITE 4 = RED 5 = ORANGE 6 = BLUE 7 = GREEN/YELLOW</p>	 <p>REF. KEYWAY TO FLAT 9.3 [0.37] REF. 11.6 [0.46] BASIC THRU NON-ROTATIONAL THRU</p>	CONTACT CARRIER MATERIAL	NYLON or PBT
		CONTACT MATERIAL/PLATING	BRASS/GOLD
		CONNECTOR HOUSING MATERIAL/PLATING	BRASS/NICKEL
		O-RING/GASKET MATERIAL	RUBBER (NITRILE OR FPM)
		MANUFACTURER RATED CURRENT [A]	20 A
		UL RATED CURRENT [A]	12 A
		RATED VOLTAGE [V]	300 V
		CONDUCTOR INSULATION MATERIAL	PVC
		NUMBER OF CONDUCTORS [AWG]	7x14 AWG
		TEMPERATURE RANGE	-40°C TO +105°C (-40°F TO +221°F)
PROTECTION CLASS	IEC IP67		
MAXIMUM PANEL THICKNESS	6.5 [0.256]		

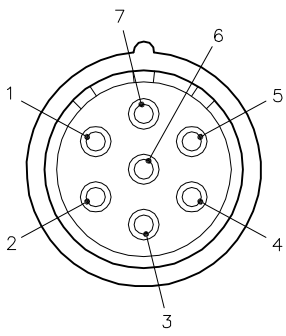
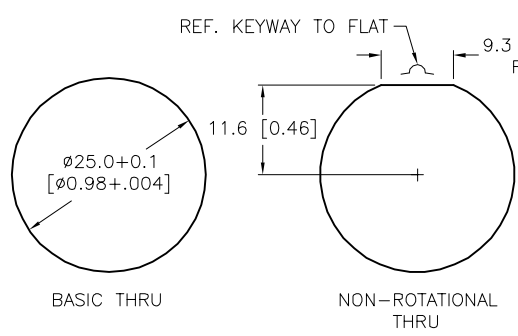
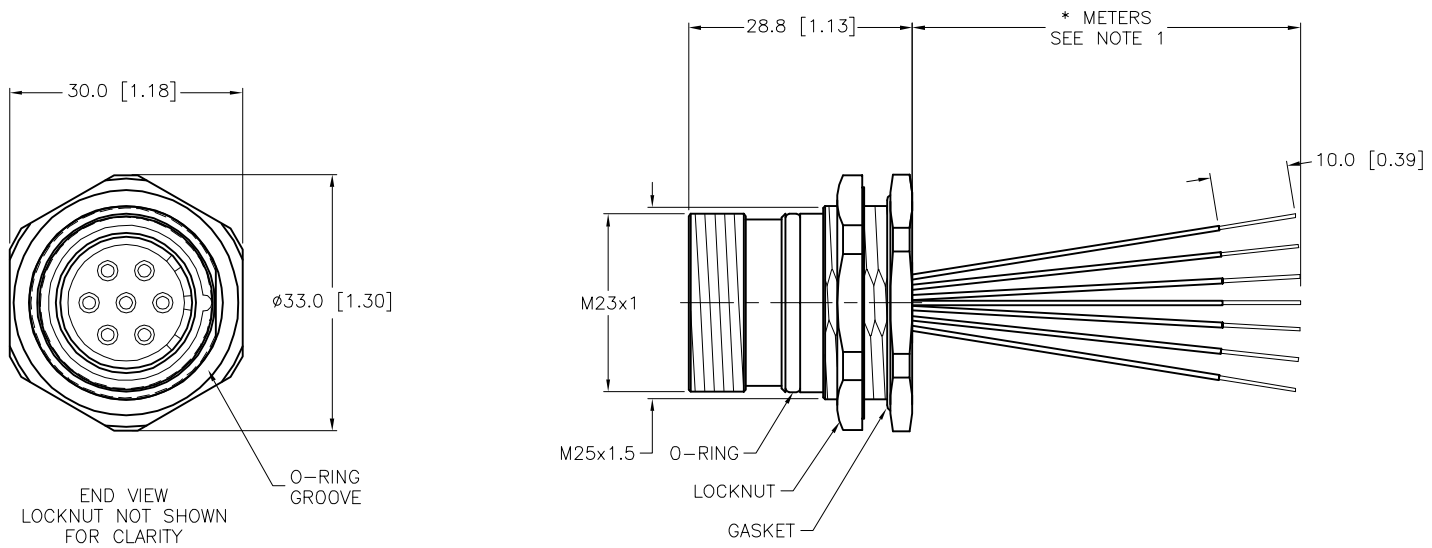

CABLE LENGTH	TOLERANCE*
ALL LENGTHS	+ 4% (OR 50mm) OF LENGTH - 0% (OR 0mm) OF LENGTH WHICHEVER IS GREATER
STRIP LENGTH	TOLERANCE*
0-7mm	±0.5mm
8-29mm	±1.0mm
30-49mm	±2.0mm
50-69mm	±3.0mm
70-100mm	±4.0mm
OVER 100mm	±5.0mm

\*UNLESS OTHERWISE SPECIFIED

SOURCE DRAWING - FOR REFERENCE ONLY

NOTES:  
1. "\*" INDICATES LEAD LENGTH IN METERS. CONTACT TURCK TO ORDER SPECIFIC LENGTHS.

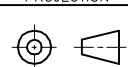
RELATED DOCUMENTS 1. 2. 3. 4.	3RD ANGLE PROJECTION 	THIS DRAWING IS CONFIDENTIAL AND THE PROPERTY OF TURCK INC. USE OF THIS DOCUMENT WITHOUT WRITTEN PERMISSION IS PROHIBITED.		3000 CAMPUS DRIVE MINNEAPOLIS, MN 55441 1-800-544-7769 (763) 553-7300 (763) 553-0708 fax www.turck.us	
		MATERIAL SEE SPECIFICATIONS	DRFT DD DATE 01/14/04	DESCRIPTION CKFD 74-7-*	
FINISH SEE SPECIFICATIONS	ALL DIMENSIONS DISPLAYED ON THIS DRAWING ARE FOR REFERENCE ONLY  CONTACT TURCK FOR MORE INFORMATION	APVD SCALE 1=1.0	UNIT OF MEASUREMENT <b>MILLIMETER [ INCH ]</b>		REV 
DO NOT SCALE THIS DRAWING		FILE: 777002869		SHEET 1 OF 1	

I	UPDATE GASKET MATERIAL SPEC	TR	11/08/19	75405
REV	DESCRIPTION	BY	DATE	ECO NO.