

FEMALE END VIEW

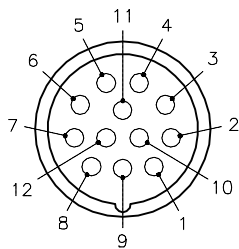

- 1 = BROWN
- 3 = BLUE
- 4 = WHITE
- 6 = GREEN
- 7 = YELLOW
- 8 = GREY
- 12 = GREEN/YELLOW

M23 connector

PANEL CUTOUT (TYPICAL)

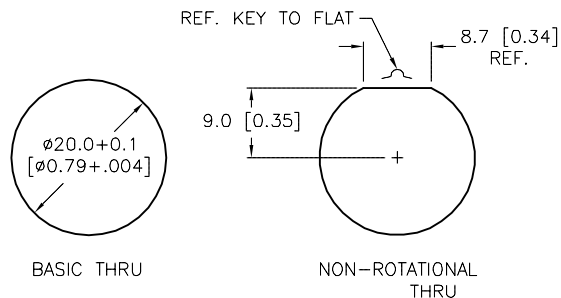

SPECIFICATIONS

CONTACT CARRIER MATERIAL/COLOR	NYLON or PBT/GRAY
CONTACT MATERIAL/PLATING	BRASS/GOLD
HOUSING MATERIAL/PLATING	BRASS/NICKEL
O-RING/GASKET MATERIAL	RUBBER (NITRILE OR FPM)
RATED CURRENT [A]	6.0 A
RATED VOLTAGE [V]	300 V
CONDUCTOR INSULATION MATERIAL	PVC
MAXIMUM CONDUCTOR SIZE (AWG)	7x18 AWG
TEMPERATURE RANGE	-40°C to +105°C (-40°F to +221°F)
PROTECTION CLASS	MEETS IEC IP67
MAXIMUM PANEL THICKNESS	3.5 [0.138]

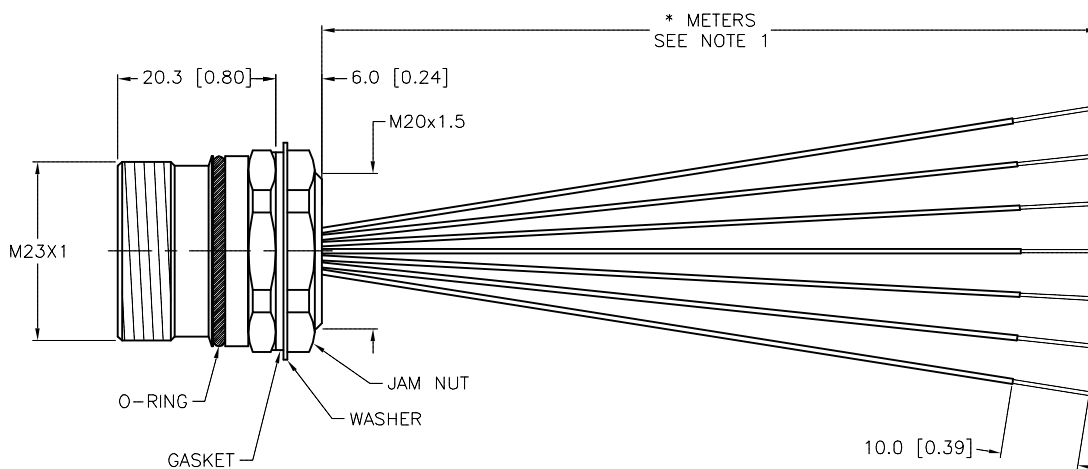
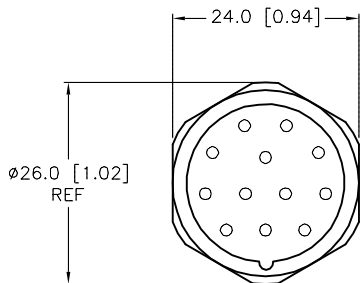

CABLE LENGTH	TOLERANCE*
ALL LENGTHS	+ 4% (OR 50mm) OF LENGTH - 0% (OR 0mm) OF LENGTH WHICHEVER IS GREATER
STRIP LENGTH	TOLERANCE*
0-7mm	±0.5mm
8-29mm	±1.0mm
30-49mm	±2.0mm
50-69mm	±3.0mm
70-100mm	±4.0mm
OVER 100mm	±5.0mm

*UNLESS OTHERWISE SPECIFIED

SOURCE DRAWING - FOR REFERENCE ONLY

NOTES:

1. "*" INDICATES LEAD LENGTH IN METERS. CONTACT TURCK TO ORDER SPECIFIC LENGTHS.

RELATED DOCUMENTS 1. 2. 3. 4.	3RD ANGLE PROJECTION 	THIS DRAWING IS CONFIDENTIAL AND THE PROPERTY OF TURCK INC. USE OF THIS DOCUMENT WITHOUT WRITTEN PERMISSION IS PROHIBITED.		3000 CAMPUS DRIVE MINNEAPOLIS, MN 55441 1-800-544-7769 (763) 553-7300 (763) 553-0708 fax www.turck.us	
	MATERIAL	DRFT CBM	DATE 03/10/99	DESCRIPTION CKF 12-7-*	
FINISH	ALL DIMENSIONS DISPLAYED ON THIS DRAWING ARE FOR REFERENCE ONLY	APVD	SCALE 1=1.0	IDENTIFICATION NO.	
CONTACT TURCK FOR MORE INFORMATION		UNIT OF MEASUREMENT MILLIMETER [INCH]		REV G	
DO NOT SCALE THIS DRAWING		FILE: 777000818		SHEET 1 OF 1	

G	UPDATE TO RUBBER (NITRILE OR FPM)	RDS	11/19/19	75412
REV	DESCRIPTION	BY	DATE	ECO NO.