

WIRING DIAGRAM

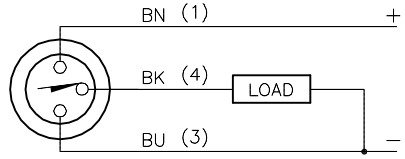

OUTPUT: AP6X

SHORT-CIRCUIT AND OVERLOAD PROTECTED

LOCKNUT LN-M8

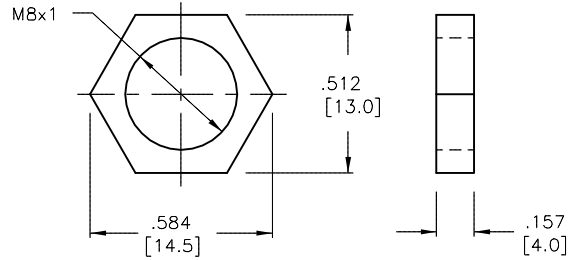

SPECIFICATIONS

RATED OPERATING DISTANCE	1.5 mm = .059" (NOMINAL)
MOUNTING MODE	FLUSH
MIN. REPEAT ACCURACY	≤ 2%
TEMPERATURE DRIFT	≤ ± 10%
HYSTERESIS	3-15%
OPERATING TEMPERATURE	-30°C to +85°C (-22°F to +185°F)
RATED OPERATIONAL VOLTAGE	10-30 VDC
RIPPLE	≤ 10%
RATED OPERATIONAL CURRENT (DC)	≤ 150 mA
NO-LOAD CURRENT	≤ 15 mA
RESIDUAL CURRENT	≤ 0.1 mA
RATED INSULATION VOLTAGE	≤ 0.5 kV
SHORT-CIRCUIT PROTECTED	YES
MAX VOLTAGE DROP	≤ 1.8 V
WIRE BREAKAGE PROTECTION	INCORPORATED
REVERSE POLARITY PROTECTION	INCORPORATED
OUTPUT FUNCTION	3-WIRE, NORMALLY OPEN
SWITCHING FREQUENCY	2.0 kHz
HOUSING MATERIAL	METAL, A4 1.4404 (AISI 316L)
ACTIVE FACE MATERIAL	PLASTIC, PA12-GF20
END CAP MATERIAL	PLASTIC, PP
CABLE	∅4.0, TPU
SHOCK RESISTANCE	30 g, 11 ms
VIBRATION RESISTANCE	55 Hz, 1 mm AMPLITUDE (IN ALL 3 PLANES)
DEGREE OF PROTECTION	IP67
SWITCHING STATUS INDICATION	LED: YELLOW

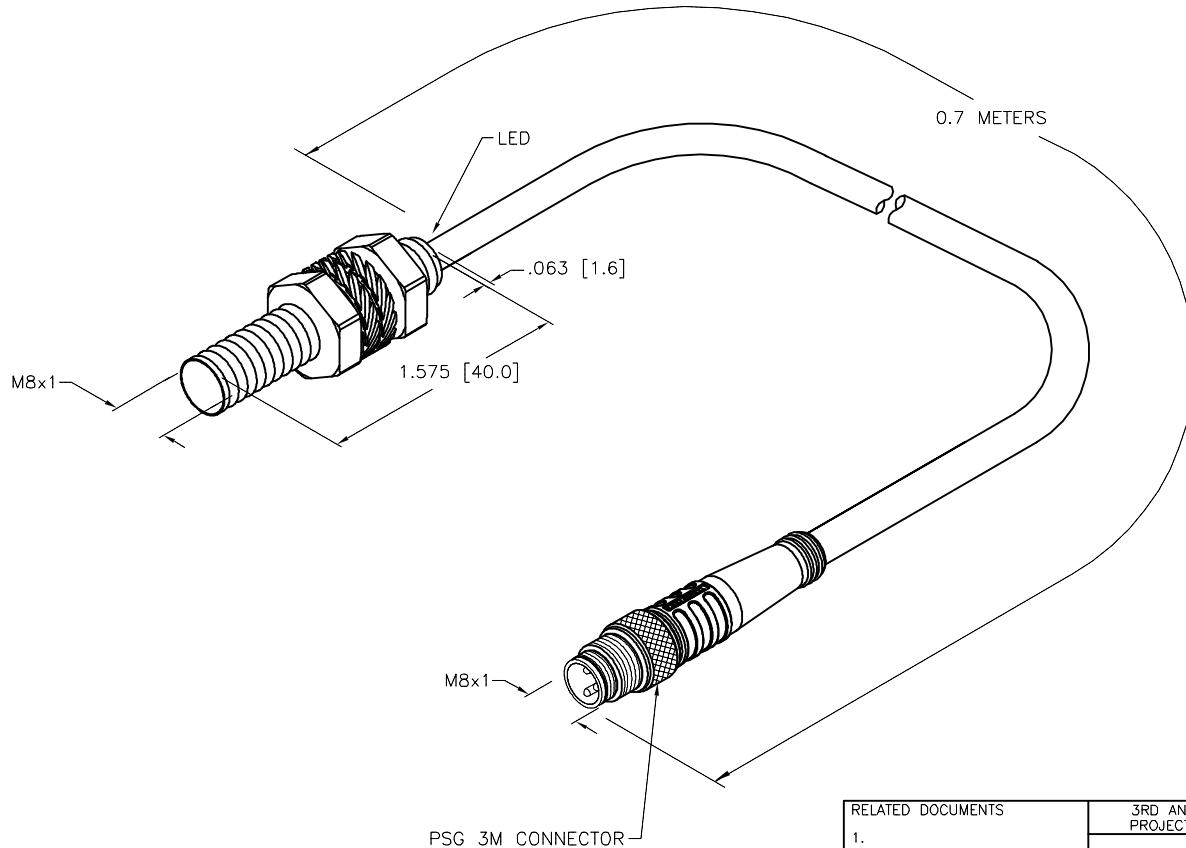

SOURCE DRAWING - FOR REFERENCE ONLY

RELATED DOCUMENTS 1. 2. 3. 4.	3RD ANGLE PROJECTION 	THIS DRAWING IS CONFIDENTIAL AND THE PROPERTY OF TURCK INC. USE OF THIS DOCUMENT WITHOUT WRITTEN PERMISSION IS PROHIBITED.		3000 CAMPUS DRIVE MINNEAPOLIS, MN 55441 1-800-544-7769 (763) 553-7300 (763) 553-0708 fax turck.com		
	MATERIAL SEE SPECIFICATIONS	ALL DIMENSIONS DISPLAYED ON THIS DRAWING ARE FOR REFERENCE ONLY	DRFT NF	DATE 03/31/15	DESCRIPTION BI 1.5U-EG08-AP6X-0.7M-PSG 3M	
			APVD K.H.	SCALE 1=1.0		
	FINISH SEE SPECIFICATIONS	CONTACT TURCK FOR MORE INFORMATION	UNIT OF MEASUREMENT INCH [MILLIMETER]		IDENTIFICATION NO. S4600500-005	REV A
DO NOT SCALE THIS DRAWING		FILE: S4600500-005		SHEET 1 OF 1		

A	DRAWING RELEASE	NF	03/31/15	
REV	DESCRIPTION	BY	DATE	ECO NO.