

Capacitive Sensor With Potentiometer BC10-S30-Y1X 10M

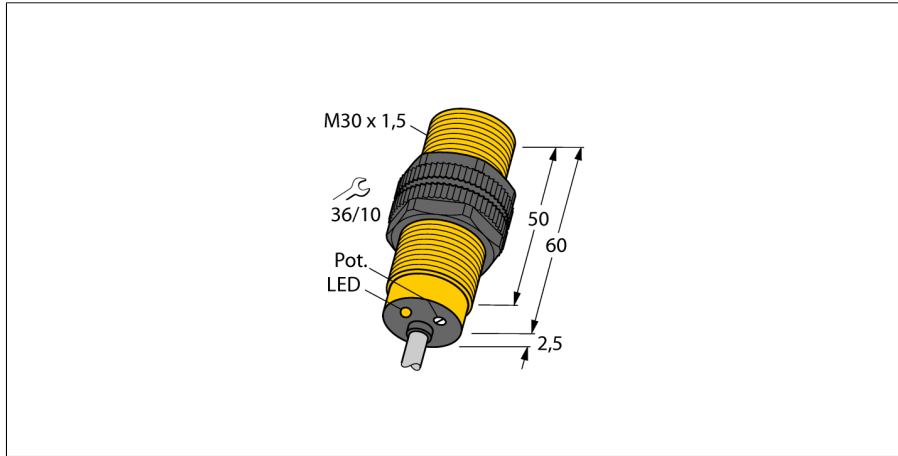

- M30 × 1.5 threaded barrel
- Plastic, PA12-GF30
- Fine adjustment via potentiometer
- DC 2-wire, nom. 8.2 VDC
- Output acc. to DIN EN 60947-5-6 (NAMUR)
- Cable connection
- ATEX category II 2 G, Ex zone 1
- ATEX category II 1 D, Ex zone 20
- SIL2 (Low Demand Mode) acc. to IEC 61508, PL c acc. to ISO 13849-1 at HFT0
- SIL3 (All Demand Mode) acc. to IEC 61508, PL e acc. to ISO 13849-1 with redundant configuration HFT1

Type	BC10-S30-Y1X 10M
ID	2010010
Rated switching distance (flush)	10 mm
Rated switching distance (non-flush)	15 mm
Secured operating distance	≤ (0.72 × S _n) mm
Hysteresis	1...20 %
Temperature drift	Typical 20 %
Repeat accuracy	≤ 2 % of full scale
Ambient temperature	-25...+70 °C
Electrical data	
Voltage	Nom. 8.2 VDC
Current consumption non-actuated	≤ 1.2 mA
Actuated current consumption	≥ 2.1 mA
Switching frequency	0.1 kHz
Oscillation frequency	According to EN 60947-5-2, 8.2.6.2 Table 9: 0.1... 2.0 MHz
Output function	2-wire, NAMUR
Tests/approvals	
Approval acc. to	KEMA 02 ATEX 1090X
Internal capacitance (C _i)/inductance (L)	150 nF/negligibly small
Device marking	Ⓢ II 2 G Ex ia IIC T6 Gb / II 1 D Ex ia IIIC T135 °C Da (max. U _i = 20 V, I _i = 20 mA, P _i = 200 mW)
Mechanical data	
Design	Threaded barrel, M30 × 1.5
Dimensions	62.5 mm
Housing material	Plastic, PA12-GF30, PEI
Admissible pressure on front cap	≤ 3 bar
Max. tightening torque of housing nut	5 Nm
Electrical connection	Cable
Cable quality	Ø 5.2mm, LifYY, PVC, 10 m
Core cross-section	2 x 0.34 mm ² mm ²
Vibration resistance	55 Hz (1 mm)
Shock resistance	30 g (11 ms)
Protection class	IP67
MTTF	448 years acc. to SN 29500 (Ed. 99) 40 °C
Switching state	LED, Yellow

Wiring Diagram

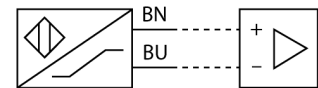

Functional principle

Capacitive proximity switches are designed for non-contact and wear-free detection of electrically conductive as well as non-conductive metal objects.

**Capacitive Sensor
With Potentiometer
BC10-S30-Y1X 10M**

Accessories

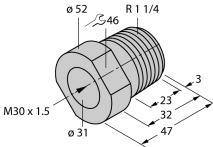
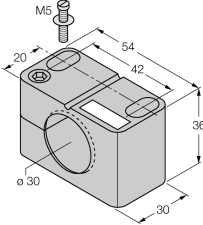
Type code	Ident-No.		Dimension drawing
MAP-M30	6950013	Mounting adapter; material: Polypropylene; sensor replacement with filled container possible (adapter remains in container during sensor replacement)	 <p>Technical drawing of a cylindrical mounting adapter. Dimensions include: outer diameter $\phi 52$, inner diameter $\phi 31$, thread specification M30 x 1.5, a chamfered edge with R 1 1/4, and various axial dimensions of 46, 23, 32, 47, and 3.</p>
BST-30B	6947216	Mounting clamp for threaded barrel sensors, with dead-stop; material: PA6	 <p>Technical drawing of a rectangular mounting clamp. Dimensions include: total length 54, distance between mounting holes 42, total width 36, and hole diameter $\phi 30$. An M5 screw is shown for mounting.</p>

Capacitive Sensor With Potentiometer BC10-S30-Y1X 10M

Operating manual

Intended use

This device fulfills Directive 2014/34/EC and is suited for use in areas exposed to explosion hazards according to EN 60079-0:2018 and EN 60079-11:2012.

Further it is suited for use in safety-related systems, including SIL2 as per IEC 61508.

In order to ensure correct operation to the intended purpose it is required to observe the national regulations and directives.

For use in explosion hazardous areas conform to classification

II 2 G and II 1 D (Group II, Category 2 G, electrical equipment for gaseous atmospheres and category 1 D, electrical equipment for dust atmospheres).

Marking (see device or technical data sheet)

⊕ II 2 G and Ex ia IIC T6 Gb and ⊕ II 1 D Ex ia IIIC T135 °C Da acc. to EN 60079-0, -11

Local admissible ambient temperature

-25...+70 °C

Installation/Commissioning

These devices may only be installed, connected and operated by trained and qualified staff. Qualified staff must have knowledge of protection classes, directives and regulations concerning electrical equipment designed for use in explosion hazardous areas.

Please verify that the classification and the marking on the device comply with the actual application conditions.

This device is only suited for connection to approved Exi circuits according to EN 60079-0 and EN 60079-11. Please observe the maximum admissible electrical values.

After connection to other circuits the sensor may no longer be used in Exi installations. When interconnected to (associated) electrical equipment, it is required to perform the "Proof of intrinsic safety" (EN60079-14).

Attention! When used in safety systems, all content of the security manual must be observed.

Installation and mounting instructions

Avoid static charging of cables and plastic devices. Please only clean the device with a damp cloth. Do not install the device in a dust flow and avoid build-up of dust deposits on the device.

If the devices and the cable could be subject to mechanical damage, they must be protected accordingly. They must also be shielded against strong electro-magnetic fields.

The pin configuration and the electrical specifications can be taken from the device marking or the technical data sheet.

Service/Maintenance

Repairs are not possible. The approval expires if the device is repaired or modified by a person other than the manufacturer. The most important data from the approval are listed.