

FEMALE END VIEW

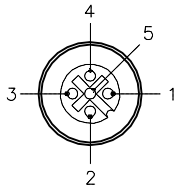

- 1 = BARE (SHIELD)
- 2 = RED (+ VOLTAGE)
- 3 = BLACK (- VOLTAGE)
- 4 = WHITE (CAN_H)
- 5 = BLUE (CAN_L)

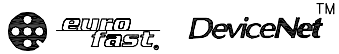

SPECIFICATIONS

HOUSING MATERIAL/PLATING	NYLON/BLACK
CONTACT MATERIAL/PLATING	BRASS/GOLD
COUPLING NUT MATERIAL/PLATING	BRASS/NICKEL
RATED CURRENT [A]	4.0 A
RATED VOLTAGE [V]	30 VAC/36 VDC
MAXIMUM WIRE SIZE	18 AWG
CABLE GRIP RANGE	6-8mm
TEMPERATURE RATING	-40°C to +85°C (-40°F to +185°F)
PROTECTION CLASS	IEC IP67

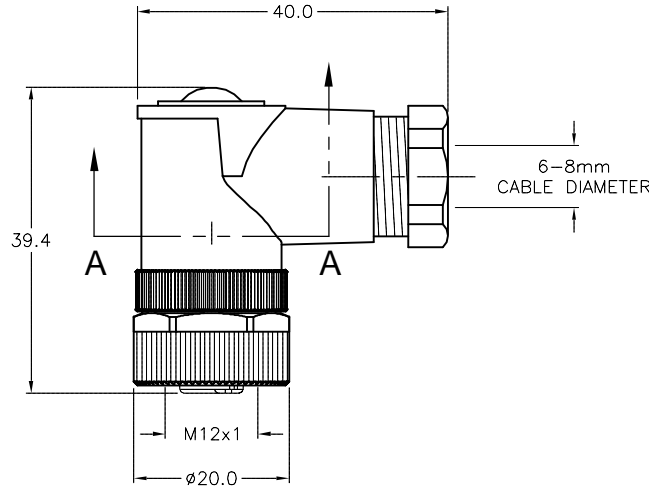

DETAIL "A"

WIRE SIDE VIEW OF CONTACT HOLDER TO SHOW LABEL DETAILS

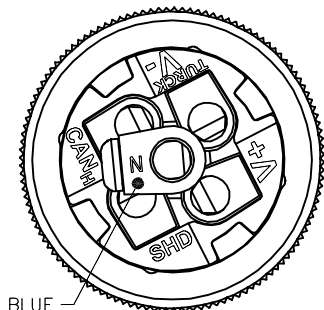

(SCALE 2:1)

LABEL DETAIL

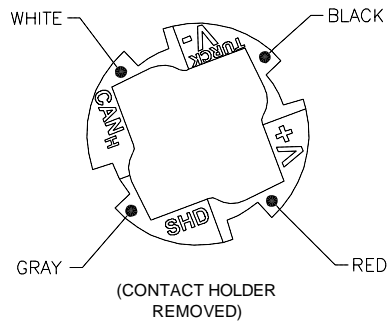

(CONTACT HOLDER REMOVED)

SOURCE DRAWING - FOR REFERENCE ONLY

RELATED DOCUMENTS 1. 2. 3. 4.	3RD ANGLE PROJECTION 	THIS DRAWING IS CONFIDENTIAL AND THE PROPERTY OF TURCK INC. USE OF THIS DOCUMENT WITHOUT WRITTEN PERMISSION IS PROHIBITED.		3000 CAMPUS DRIVE MINNEAPOLIS, MN 55441 1-800-544-7769 (763) 553-7300 (763) 553-0708 fax turck.com			
		DRFT	RDS	DATE	07/19/07	DESCRIPTION B 8251-0/PG9/DNET	
MATERIAL SEE SPECIFICATIONS	ALL DIMENSIONS DISPLAYED ON THIS DRAWING ARE FOR REFERENCE ONLY	DSGN		SCALE	1=1.0		
FINISH SEE SPECIFICATIONS		CONTACT TURCK FOR MORE INFORMATION	UNIT OF MEASUREMENT MILLIMETERS		IDENTIFICATION NO. U3-01269	REV B	
B	UPDATE CONTACT MATERIAL/PLATING, ECO	RWC	09/29/08	22596			
REV	DESCRIPTION	BY	DATE	ECO NO.	DO NOT SCALE THIS DRAWING	FILE: U3-01269	SHEET 1 OF 1