



5200 SERIES RELAY DATA SHEET

Series 5200 Solid-State relays are designed for controlling a wide variety of high and low resistance liquids, moist bulk materials, and general purpose use in applications requiring a low voltage control circuit.

Supplied as compact package units, they combine performance-proven solid-state printed circuitry with an electromechanical load relay that features isolated double pole / double throw contacts for energizing pump motors, valves and other operating equipment.

Equipped with silicon controlled rectifiers, the 5200 Series Relay assures years of service without change in operating characteristics. The Relay will operate with less than a 10% difference between pull-in and drop-out resistance and can be mounted in any position. Units are field selectable for either DIRECT or INVERSE operation.

Series 5200 Solid-State Relays are available in two sensitivity ranges, LOW and HIGH.

LOW SENSITIVITY:

This relay is designed for the control or detection of electrically conductive liquids with low to medium specific resistance. Typical liquids are potable and waste water, most acids, plating solutions, fruit juices, soup, beer, milk, and soft drinks. With a low voltage AC electrode potential, this relay operates with no shock or sparking hazard. It is ideal for food, drug, dairy, and chemical processing applications.

HIGH SENSITIVITY:

This relay is recommended for the control or detection of electrically conductive liquids with medium to high specific resistance. Typical liquids are distilled and de-ionized water steam condensate, alcohol, glycols and anhydrous ammonia. It is also suitable for detecting or controlling ore, foundry sand and other bulk materials with low moisture content. With a low voltage DC electrode potential and no existing shock hazard in the electrode circuit, this relay is an excellent choice for use in applications where the relay must be located many thousands of feet away from the electrodes.

SPECIFICATIONS

Dual Input Voltage:

115 or 240 VAC 50/60 Hz (+10% / -20%)

Power Consumption:

9 Volt-Amperes, 6 watt Max.

Contact Rating:

10 Amps at 120 or 240 VAC or 28 VDC
1/4 HP at 120 VAC and 1/3 HP at 240 VAC

Output Contact Arrangement:

Double pole, double throw load contacts
plus single pole, double throw holding
circuit contacts

Ambient Temperatures:

-40° F to 180° F
-40° C to 82.2° C

Sensing Circuit:

Low Sensitivity: 8 volt ac and less than
30 ma short-circuit.
High Sensitivity: 9.6 volt dc and less than
1 ma short-circuit.



DIMENSIONAL DATA

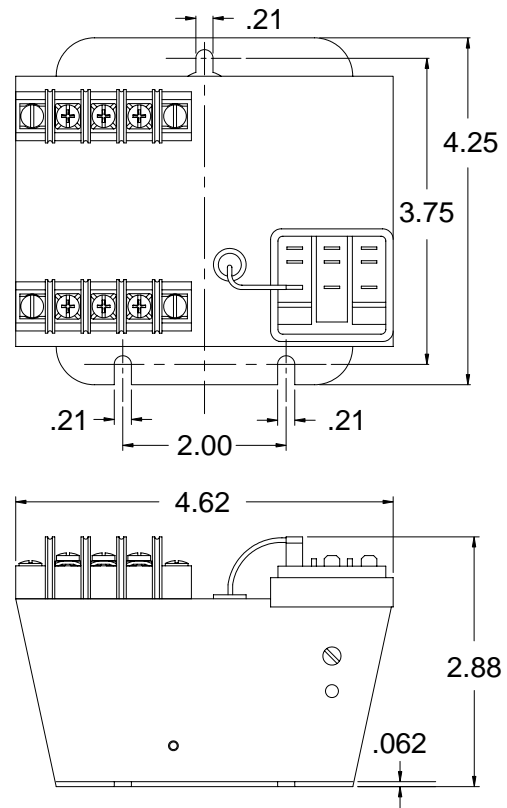

SENSITIVITY SELECTION

B / W level control systems use the liquid as an electrical conductor to complete the Series 5200 relay sensing circuit, and it is necessary that the relay have an operating sensitivity greater than the resistance of the liquid to be controlled. The sensitivity of both models of the Series 5200 relay is determined by the value of the replaceable R1 resistor used. Since the resistance of liquids vary over a large range, a wide selection of fixed and variable sensitivities are available as detailed on the chart below. When operating from contacts of pilot switches, any of the resistors can be used but it is recommended that the smallest R1 resistor value be used.

FIXED SENSITIVITY

Both the low and high sensitivity relays are shipped from the factory with a complete set of fixed resistors. The proper R1 resistor must be selected during installation as shown in the wiring diagrams. Fixed sensitivity type relays are recommended when operating from pilot switch contacts or when the liquid being controlled is always the same.

VARIABLE SENSITIVITY

Both the low and high sensitivity relays are available with variable resistance potentiometers. A kit can be supplied for field installation. The low sensitivity model has two variable sensitivity ranges and the high sensitivity model has three variable sensitivity ranges as shown in the table below. Variable sensitivity models are recommended for applications where the relay is to be used on a variety of liquids. They also should be used for interface detection or on applications where foam is present and it is necessary to operate on the liquid phase only.

SENSITIVITY SELECTION CHART

	R1 SENSITIVITY RESISTOR		SENSING CIRCUIT LIMITATIONS		MAXIMUM OPERATING SENSITIVITY	
	Nominal Resistance	Part Number	Maximum Capacitance Electrode Wire to Ground	Maximum Lead Wire Lengths in Feet	Direct Operation	Inverse Operation
LOW SENSITIVITY RELAY	270 Ohms	04154900	3.7 Microfarads	15,000	200 Ohms	330 Ohms
	470 Ohms	04155000	1.7 Microfarads	15,000	340 Ohms	570 Ohms
	1,000 Ohms	04138300	.80 Microfarads	15,000	730 Ohms	1,200 Ohms
	1,800 Ohms	04155100	.44 Microfarads	11,000	1,300 Ohms	2,200 Ohms
	3,900 Ohms	04155200	.20 Microfarads	5,000	2,800 Ohms	4,800 Ohms
	10,000 Ohms	04149400	.08 Microfarads	2,000	7,300 Ohms	12,000 Ohms
	22,000 Ohms	04138400	.036 Microfarads	900	16,000 Ohms	26,000 Ohms
	Variable	52110205	.80 Microfarads	15,000	100-700 Ohms	200-1200 Ohms
	Variable	52110206	.036 Microfarads	900	.6K-15K Ohms	1K-24K Ohms
	HIGH SENSITIVITY RELAY	10,000 Ohms	04149400	120 Microfarads	50,000	9,600 Ohms
22,000 Ohms		04138400	55 Microfarads	50,000	21,000 Ohms	21,000 Ohms
68,000 Ohms		04138500	18 Microfarads	50,000	66,000 Ohms	66,000 Ohms
.33 Megohms		04138600	4.0 Microfarads	50,000	.31 Megohms	.32 Megohms
.82 Megohms		04138800	1.5 Microfarads	35,000	.80 Megohms	.81 Megohms
2.2 Megohms		04138900	0.5 Microfarads	12,000	2.1 Megohms	2.2 Megohms
5.6 Megohms		04139000	0.2 Microfarads	4,000	5.4 Megohms	5.6 Megohms
12.0 Megohms		04139100	0.1 Microfarads	2,000	11.6 Megohms	12.0 Megohms
Variable		52120205	12 Microfarads	50,000	2K-100K Ohms	2K-100K Ohms
Variable		52120206	1.2 Microfarads	28,000	7K-1.0 Megohms	7K-1.0 Megohms
Variable		52120207	0.2 Microfarads	4,000	47K-5.0 Megohms	47K-5.0 Megohms

ELECTRODE LEAD WIRES

Shielded cable is not required, and ordinary insulated wire can be used for electrode leads. Lead wires should be isolated from, not run in the same conduit with, power and load carrying circuits to avoid direct coupling with these circuits. While capacitance of the lead wire to ground has some slight affect on sensitivity, this factor need only be considered when the relay is located more than 900 feet away from the electrodes. (Reference the **SENSITIVITY SELECTION CHART**)

5200 SERIES SOLID-STATE RELAY CATALOG NUMBERING SYSTEM

5200 - LF1 - N1

RELAY CODE	ENCLOSURE TYPE
OC	Open Chassis
N1	NEMA 1, General Purpose
N4	NEMA 4, Weather Proof, Watertight / Dust Tight
N4X	NEMA 4X, Fiberglass, Watertight, Dust Tight, Corrosion Resistant
N7	NEMA 7, Class I, Group D; Class II, Groups E, F & G
N12	NEMA 12, Oil Tight

SEE CATALOG SECTION 1500 FOR ENCLOSURE DIMENSIONS

RELAY CODE	R1 SENSITIVITY RESISTANCE	TYPICAL LIQUIDS
LF1 Fixed	270 ohms	All metallic circuits, B / W Unifloat®
	470 ohms	Strong electrolytes: Plating solutions
	1,000 ohms	Weak electrolytes: Ammonium hydroxide, borax, acetic acid
	1,800 ohms	Most food processing applications: Beer, wine, fruit juices, milk, buttermilk
	3,900 ohms	Highly corrosive acid or caustic solutions where electrode current must be minimized to extend electrode life: Hydrochloric acid, sulfuric acid. etc.
	10,000 ohms	Ordinary water with medium to high mineral content, sewage, water soluble oil and starch solutions.
	22,000 ohms	Most water with low mineral content, soft water - (<i>not distilled or de-ionized water</i>). Use High Sensitivity Relay Control
LV1 Variable	Variable 100-700 ohms	Same as above for 270, 470, and 1,000 ohms Fixed Relays
LV1 Variable	Variable .6K-15K ohms	Same as above for 1,800 thru 22,000 ohms Fixed Relays
HF2 Fixed	10,000 ohms	Ordinary water with medium to high mineral content, sewage, water soluble oil and starch solutions, long distance applications.
	22,000 ohms	Water with low mineral content, soft water - (<i>not distilled or de-ionized water</i>), sugar syrup solutions, long distance applications.
	68,000 ohms	Steam condensate, corn syrup, strong alcohol solutions up to 50%
	330,000 ohms	Alcohol solutions up to 70%
	820,000 ohms	De-ionized or distilled water, 95% glycerin, 90% Hydrogen peroxide, 95% ethyl alcohol, granular solids with high moisture content
	2.2 Megohms	Glacial acetic acid, acetone, granular solids with high moisture content
	5.6 Megohms	M.E.K. (Methyl ethyl keytone)
12.0 Megohms	Anhydrous ammonia	
HV3 Variable	Variable 2K-100K ohms	Same as above for 10,000 thru 68,000 ohms Fixed Relays
HV4 Variable	Variable 7K-1.0 Megohms	Same as above for 330,000 thru 820,000 ohms Fixed Relays
HV5 Variable	Variable 47K-5.0 Megohms	Same as above for 2.2 and 5.6 Megohms Fixed Relays

Note: D1 water, glycols, alcohols and granular solids may require the 2.2, 5.6 or 12.0 Megohms R1 resistors depending upon their purity or moisture content.

GROUND CONNECTIONS

In all installations, a good external ground connection and a dependable return circuit to the liquid are required. In most instances, grounding to a metal pipe leading to the tank is suitable, but electrical conduit should not be used for this purpose.

If a good ground connection to the liquid is not available, an additional ground electrode is required. When used, the ground electrode should extend slightly below the longest operating electrode. In addition, it is also desirable to ground the relay chassis directly to the ground terminal or through a relay mounting screw.

SERIES 5200 RELAY OPERATION

Positive fail-safe control can be obtained simply by connecting the proper R1 resistor to the terminal block for direct or inverse operation as shown in the diagrams.

DIRECT OPERATION

In *direct operation*, the load relay is energized when liquid contacts the *upper* electrode, or Unifloat® reed switch, and electrode current is flowing.

INVERSE OPERATION

In *inverse operation*, the load relay is energized when the liquid falls below the *lower* electrode, or Unifloat® reed switch, and current ceases to flow.

DIRECT OPERATION FROM B/W ELECTRODES

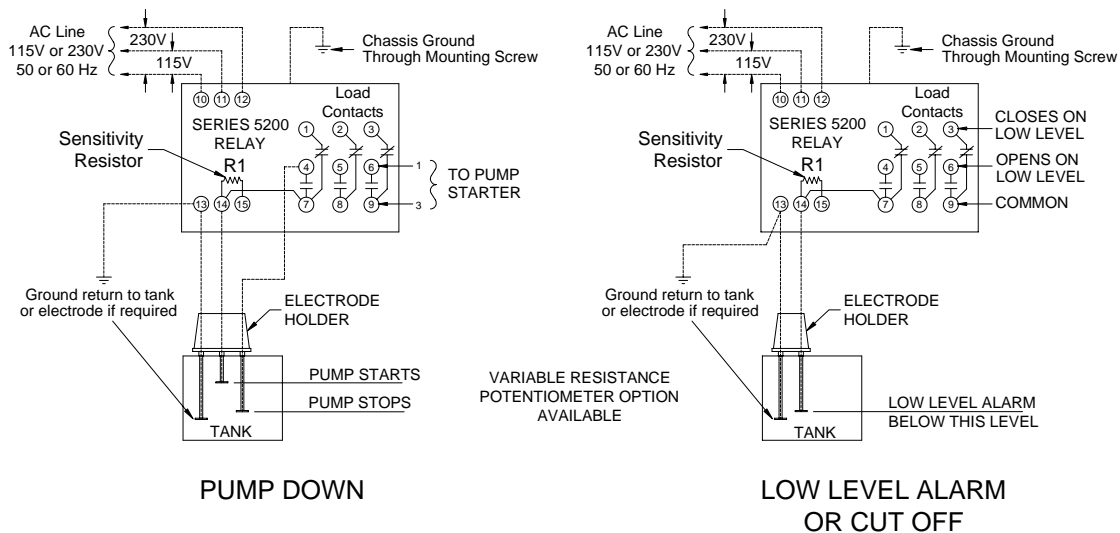

INVERSE OPERATION FROM B/W ELECTRODES

