



G438-0001

ULTRA SLIMPAK® G438-0001

Potentiometer Input Field Configurable Isolator

Provides an Isolated, Linearized DC Output
in Proportion to a Potentiometer Input



- Potentiometers from 100 Ohms to 100K Ohms
- Wide Ranging Zero & Span Adjustability
- Field Configurable Output Ranges: 0-5V, 0-10V, 0-1mA, 0-20mA and 4-20mA
- Ultra Slim Housing for High Density Installations
- Flexible Power Supply Accepts 9 to 30 VDC
- ASIC Technology for Enhanced Reliability
- RoHS Compliant

Description

The G438 is a DIN rail mount, potentiometer input signal conditioner with 1800VDC isolation between input, output and power. The input provides a constant voltage and is designed to accept any three-wire potentiometer from 100 Ohms to 100K Ohms. The field configurable output is switch selectable providing either a 0-5V, 0-10V, 0-1mA, 0-20mA or 4-20mA DC signal.

Wide ranging precision zero and span pots used in conjunction with DIP switches allow 80% adjustability of offset and gain to transmit a fullscale output from any 20% portion of the potentiometer input.

Application

The G438 is useful in transmitting process control setpoints to remote PID controllers or interfacing position sensors to data acquisition and control systems. The high density DIN rail mounting offers an extremely compact solution for saving valuable panel space.

In a valve positioning application a potentiometer is sometimes used as a feedback signal. Quite often a wide open valve is only a 25% turn of the feedback potentiometer. In a case such as this, the G438 can easily be adjusted with the zero and span to provide a fullscale output signal (e.g. 4-20mA) representing 0-25% or even 50-75% of the potentiometer input.

Configuration

Unless otherwise specified, the factory presets the Model G438 as follows:

Input Range: 0 to 100%
Output: 4 to 20mA.

The DC power input accepts any DC source between 9 and 30V; typically a 12V or 24VDC source is used (see Accessories). For other output ranges, refer to Tables 1 and 2 to reconfigure switches SW1 and SW2 for the desired input and output ranges.

WARNING: Do not change switch settings with power applied. Severe damage will result!

Calibration

Note: To maximize thermal stability, final calibration should be performed in the operating installation, allowing approximately 1 to 2 hours for warm up and thermal equilibrium of the system.

1. With power disconnected, set the output and input switch selectors (SW1 and SW2) to the desired ranges (Tables 1 and 2).
2. Connect the input and output as shown in Figure 1. Connect the output to the device (or a load approximately equivalent to the device) and apply power.
3. Set the input potentiometer to the desired minimum and adjust the zero potentiometer for the desired minimum output.
4. Set the input potentiometer to the desired maximum and adjust the span potentiometer for the desired maximum output.
5. Repeat steps 3 and 4, if necessary, for best accuracy.

Table 1: G438 Input Ranges

Span	Selector SW2					
	1	2	3	4	5	6
20 - 100%						
45 - 100%	■					
85 - 100%		■				
Offset						
	1	2	3	4	5	6
0 - 20%						
20 - 45%				■		
45 - 65%			■			
65 - 80%			■	■		
Key: ■ = 1 = ON or Closed						

Table 2: G438 Output Ranges

Output	SW1							
	1	2	3	4	5	6	7	8
0 to +5V	■	■	■	■				
0 to +10V	■		■	■				
0 to 1mA		■	■	■				
4 to 20mA						■	■	■
0 to 20mA	■	■				■	■	■
Key: ■ = 1 = ON or Closed								

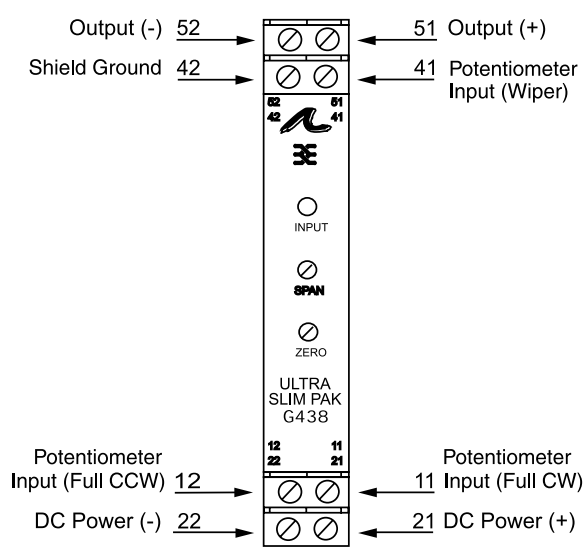

Figure 1: Wiring Diagram for G438

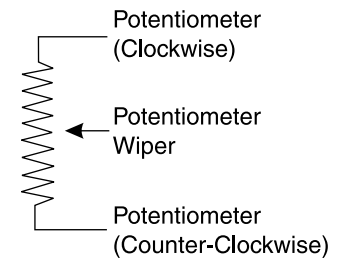

Figure 2: Potentiometer Wiring for G438

Note: All Ultra SlimPak modules are designed to operate in ambient temperatures from 0 to 55°C when mounted on a horizontal DIN rail. If five or more modules are mounted on a vertical rail, circulating air or model HS01 Heat Sink is recommended. Refer to HS01 Technical Bulletin (#721-0549-00) or contact the factory for assistance.

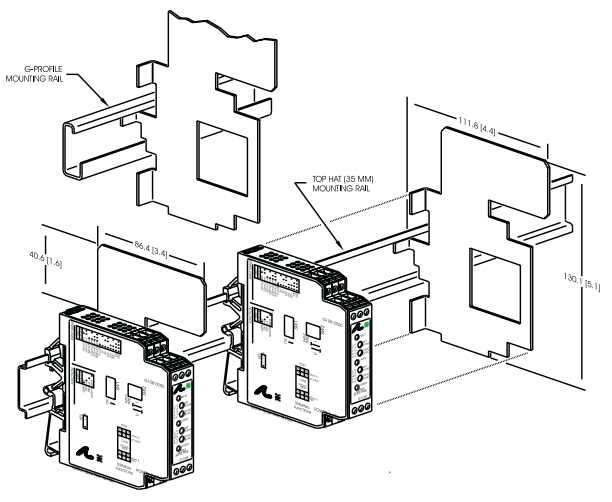

Figure 3: Mounting Multiple Modules

Specifications

Potentiometer Input:

- Resistance (End to End):
 - 100 Ohms up to 100K Ohms
- Input Impedance: >1M Ohms
- Input Excitation: 500mV, 5mA max. drive.
- Zero Turn-Up: 80% of full scale input
- Span Turn-Down: 80% of full scale input (Table 1)
- Common Mode Rejection:
 - 1800VDC (input to ground)

Output:

- Voltage:
 - Output: 0-5V, 0-10V
 - Source Impedance: <10 Ohms
 - Drive: 10mA, max. (1K Ohms min. @ 10V)
- Current:
 - Output: 0-1mA, 0-20mA, 4-20mA
 - Source Impedance: >100K Ohms
- Compliance:
 - 0-1mA; 7.5V, max. (7.5K Ohms, max.)
 - 0-20mA; 12V, max. (600 Ohms, max.)
 - 4-20mA; 12V, max. (600 Ohms, max.)

Accuracy (Including Linearity, Hysteresis):

±0.1% maximum at 25°C.

Stability:

Temperature: <±0.05%/°C max. of full scale range.

Response Time (10 to 90%):

<200mSec., typical.

Common Mode Rejection:

DC to 60Hz: 120dB

Isolation:

1800VDC between line pwr & input, output

EMC Compliance (CE Mark):

Emissions: EN50081-1
Immunity: EN50082-2
Safety: EN50178

LED Indication (green):

Active DC power

Humidity (Non-Condensing):

Operating: 15 to 95% @ 45°C
Soak: 90% for 24 hours @ 65°C

Temperature Range:

Operating: 0 to 55°C (32 to 131°F)
Storage: -25 to 70°C (-13 to 158°F)

Mounting:

Horizontal DIN rail mounting is recommended.
Vertical DIN rail mounting requires heatsink (model HS01, included) and circulating air is recommended.

Power:

Consumption: 1.5W typical, 2.5W max
Range: 9 to 30VDC

Weight:

0.48 lbs

Agency Approvals:

UL recognized per standard UL508
(File No.E99775)
CE Conformance per EMC directive 89/336/EEC
and low voltage 73/23/EEC
RoHS Compliant

Ordering Information

Models & Accessories

Specify:

- Model: **G438-0001**
- Accessories: (see Accessories)
- Optional Custom Factory Calibration: specify **C620** with desired input and output range.

Accessories

SlimPak "G" series modules will mount on standard TS32 (model MD02) or TS35 (model MD03) DIN rail. In addition, the following accessories are available:

- HS01** Heat Sink
- MD03** TS35 x 7.5 DIN rail
- WV905** 24VDC Power Supply (0.5 Amp)
- H910** 24VDC Power Supply (1 Amp)
- H915** 24VDC Power Supply (2.3 Amp)
- MB03** End Bracket for MD03
- C664** I/O Descriptive Tag

Dimensions

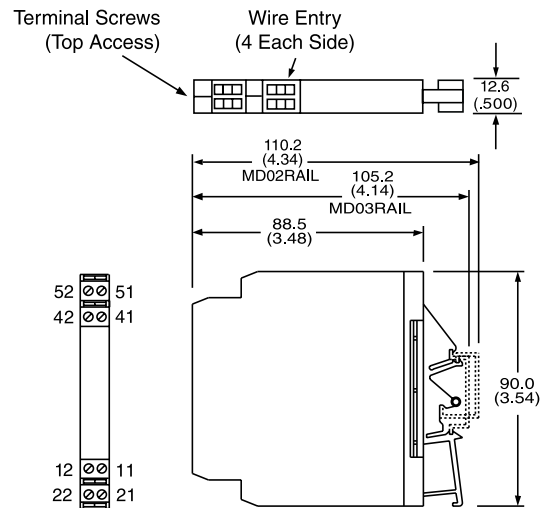

Dimensions are in mm (inches)



Eurotherm, Inc

741-F Miller Drive
Leesburg, VA 20175-8993
703-443-0000

info@eurotherm.com or www.eurotherm.com/actionio



Printed on recycled paper

Factory Assistance

For additional information on calibration, operation and installation contact our Technical Services Group:

703-669-1318

actionsupport@eurotherm.com

721-0650-00-F 02/09 Copyright© Eurotherm, Inc 2009