



96 Hinge

Lift-off · In-line · Zinc

- Allows for quick, easy door removal
- Door can also be permanently installed

Material and Finish

Zinc alloy, black powder coated

Performance Details

	Radial Load	Axial Load
Max. static load	1300 N (300 lbf)	2200 N (500 lbf)
Average ultimate load	3300 N (750 lbf)	9300 N (2100 lbf)

Installation Notes

Screws not supplied.

Max. tightening torque of screw:
8.5 N·m (75 in·lbf)

Calculate screw length using the following formula:

Door thickness + 5 (.200)

In-line mount preparation:

To allow for 180° rotation R or S must be < 25.4 (1.00).

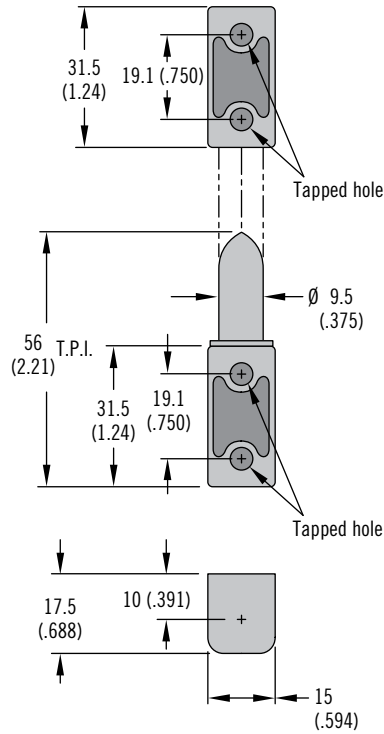

For Lift-Off Mounting

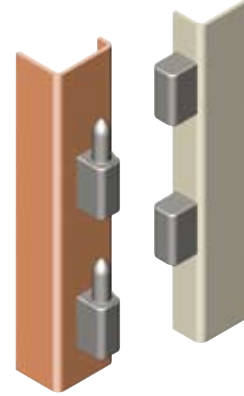

For Non Lift-Off Mounting

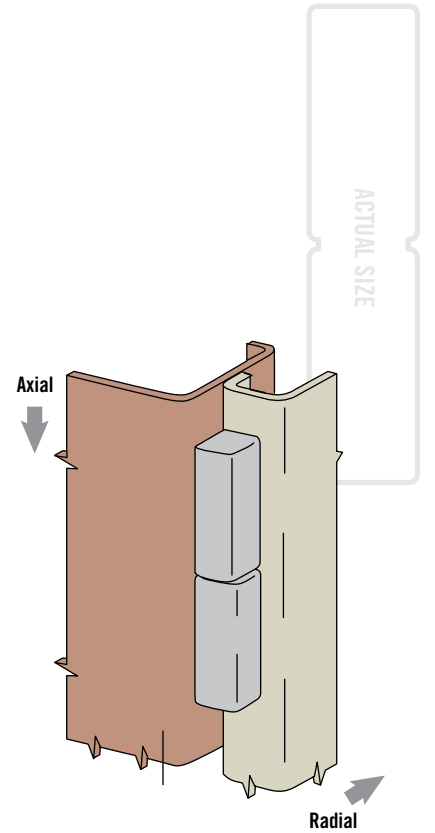
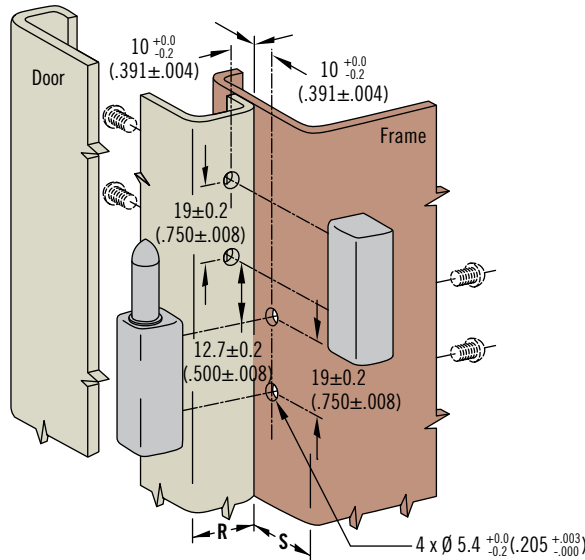
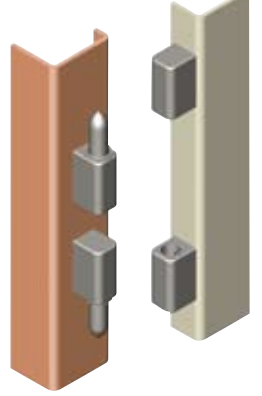

Part Number

See Table

Tapped Hole	Part Number
Imperial 10-32	96-10-500-50
Metric M5 x 0.8	96-50-500-50

Dimensions in millimeters (inch) unless otherwise stated



www.southco.com/96

96 Hinge

Lift-off · Offset · Zinc



Type B

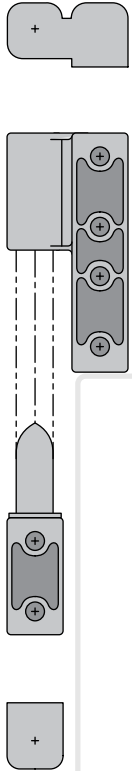

Type A

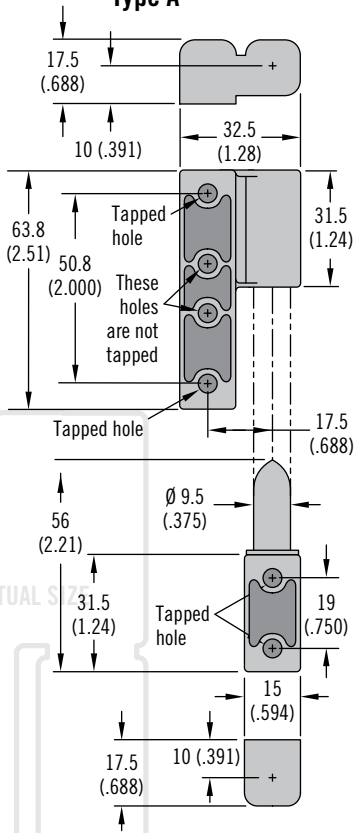

For Lift-Off Mounting

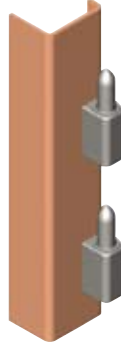

For Non Lift-Off Mounting

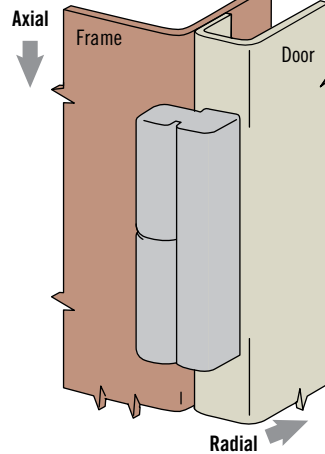
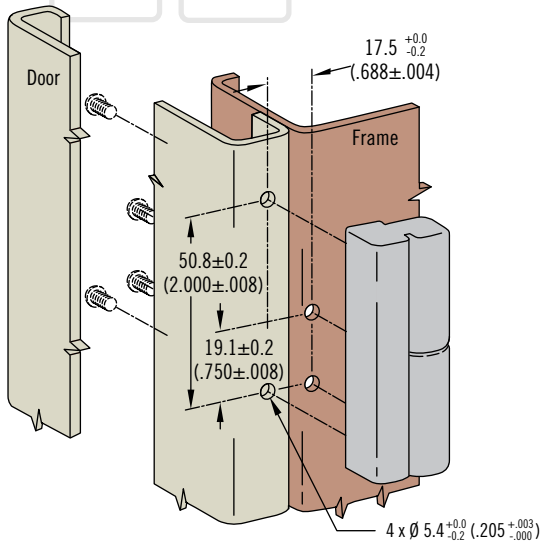
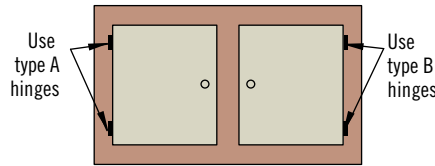
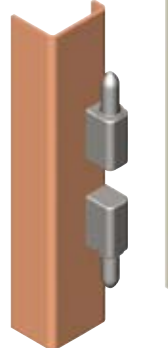

- Allows for quick, easy door removal
- Door can also be permanently installed

Material and Finish

Zinc alloy, black powder coated

Performance Details

	Radial Load	Axial Load
Max. static load	1300 N (300 lbf)	2200 N (500 lbf)
Average ultimate load	3300 N (750 lbf)	9300 N (2100 lbf)

Installation Notes

Screws not supplied.

Max. tightening torque of screw:
8.5 N·m (75 in·lbf)

Calculate screw length using the following formula:

Door thickness + 10 (.400)

Tapped Hole	Part Number	
	Type A	Type B
Imperial 10-32	96-10-510-50	96-10-520-50
Metric M5 x 0.8	96-50-510-50	96-50-520-50

Part Number

See table



96 Hinge

Lift-off · In-line · Zinc and stainless steel

- Allows for quick, easy door removal
- Door can also be permanently installed

Material and Finish

Zinc alloy, chrome plated, powder coated or stainless steel

Performance Details

Radial load

Max. static load:

Zinc alloy: 1300 N (300 lbf)

Stainless steel: 3000 N (670 lbf)

Axial Load

Max. static load:

Zinc alloy: 2200 N (500 lbf)

Stainless steel: 5000 N (1120 lbf)

Installation Notes

Screws not supplied.

Attach hinge with four M5 x 0.8

Max. screw length = door

(or frame) thickness + 10 (.400)

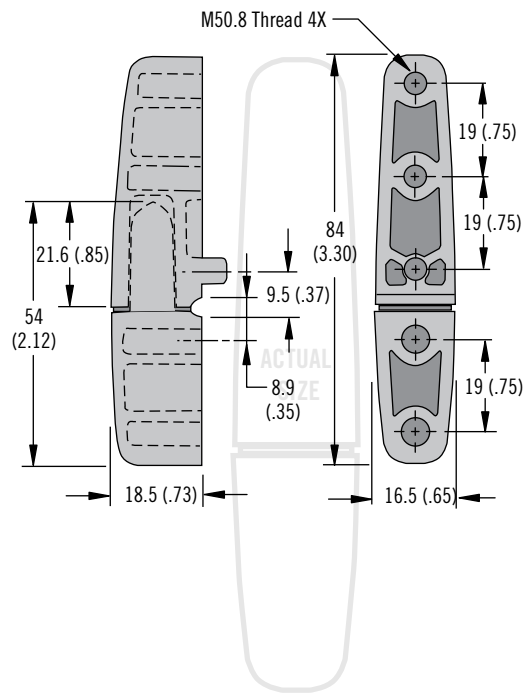

For Lift-Off Mounting

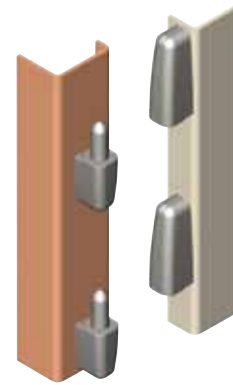

For Non Lift-Off Mounting

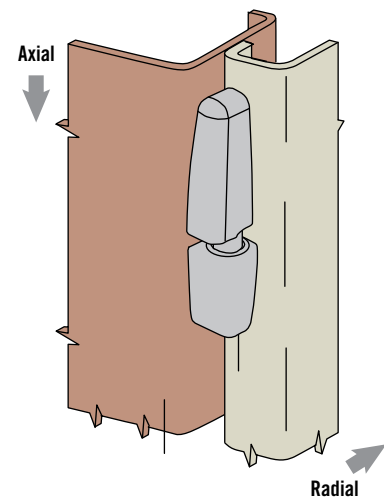
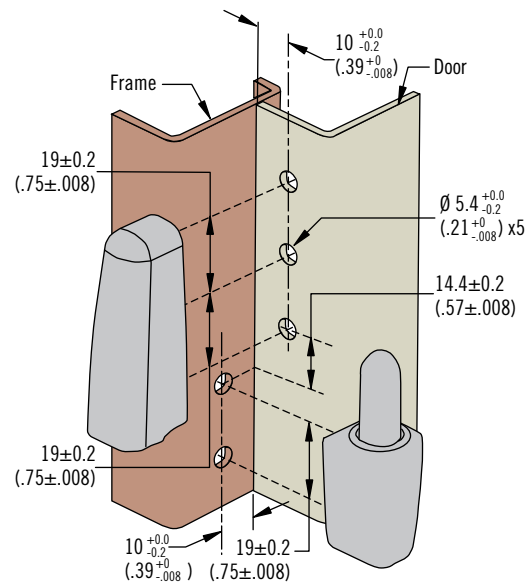
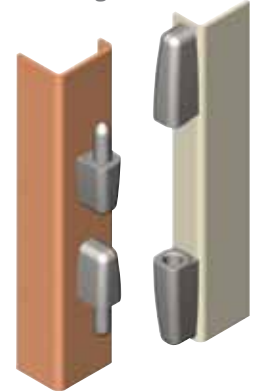

Part Number

See table

Material & Finish	Part Number
Zinc alloy, bright chrome	96-MA-80-10
Zinc alloy, black powder coated	96-MA-80-50
Zinc alloy, satin chrome	96-MA-80-20
Stainless steel, polished	96-MA-80-24

Dimensions in millimeters (inch) unless otherwise stated



www.southco.com/96

southco
CONNECT · CREATE · INNOVATE



96 Hinge

Lift-off · Offset · Zinc and stainless steel

Type A

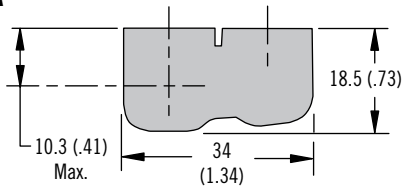

Type B

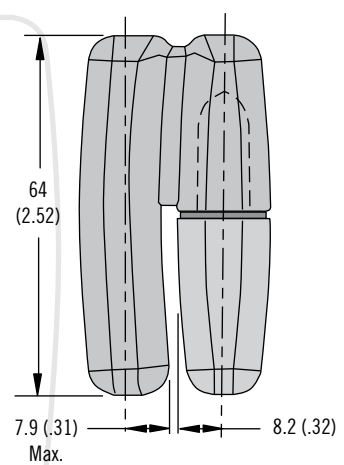
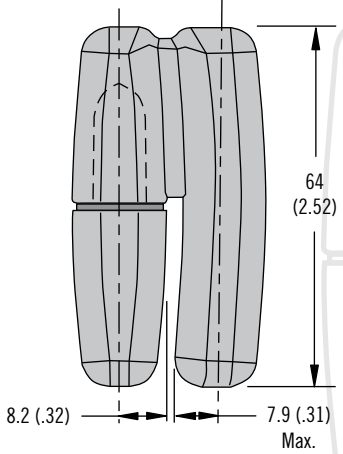
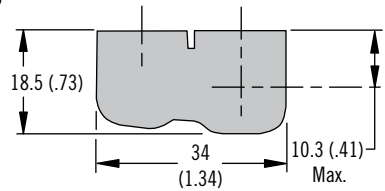

ACTUAL SIZE

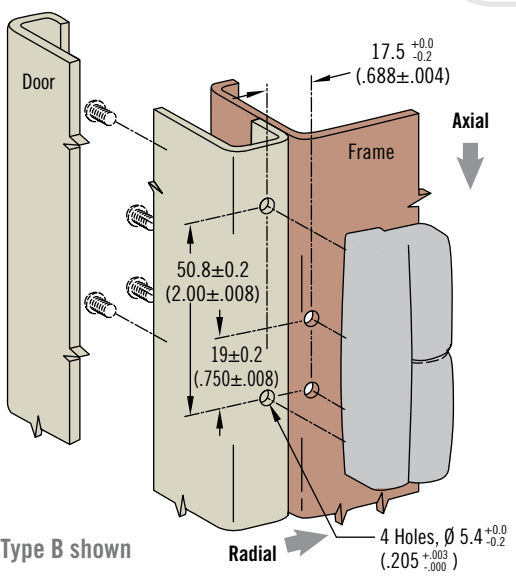

Type B shown

For Lift-Off Mounting

For Non Lift-Off Mounting

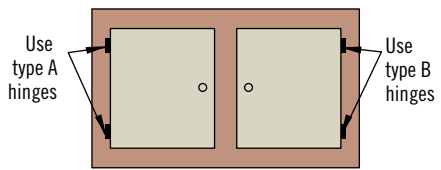
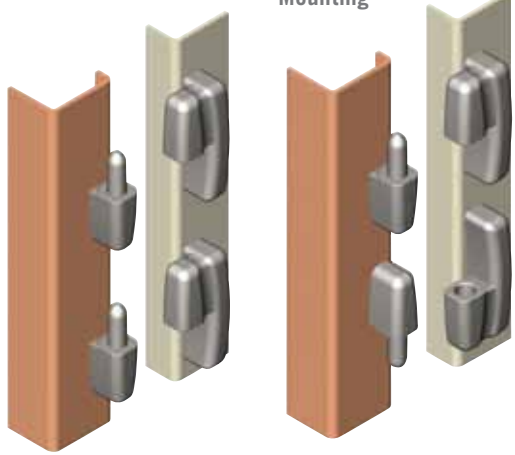

- Allows for quick, easy door removal
- Door can also be permanently installed

Material and Finish

Zinc alloy, chrome plated, powder coated or stainless steel

Performance Details

Radial load
 Max. static load:
 Zinc alloy: 1300 N (300 lbf)
 Stainless steel: 3000 N (670 lbf)

Axial Load
 Max. static load:
 Zinc alloy: 2200 N (500 lbf)
 Stainless steel: 5000 N (1120 lbf)

Installation Notes

Screws not supplied.
 Attach hinge with four M5 x 0.8
 Max. screw length = door (or frame) thickness + 10 (.400)

Material & Finish	Part Number	
	Type A	Type B
Zinc alloy, bright chrome	96-MA-8A-10	96-MA-8B-10
Zinc alloy, black powder coated	96-MA-8A-50	96-MA-8B-50
Zinc alloy, satin chrome	96-MA-8A-20	96-MA-8B-20
Stainless steel, polished	96-MA-8A-24	96-MA-8B-24

Part Number

See table



96 Hinge

Lift-off · In-line · Offset · Plastic

- Allows for quick, easy door removal
- Corrosion-resistant materials
- Door can also be permanently installed

Material and Finish

Glass reinforced nylon, black

Performance Details

300 Series	Radial Load	Axial Load
Max. static load	670 N (150 lbf)	1100 N (250 lbf)
Average ultimate load	1300 N (290 lbf)	2500 N (550 lbf)

400 Series	Radial Load	Axial Load
Max. static load	1300 N (300lbf)	2200 N (500lbf)
Average ultimate load	2600 N (600lbf)	5000 N (600lbf)

In-Line Knuckle Style

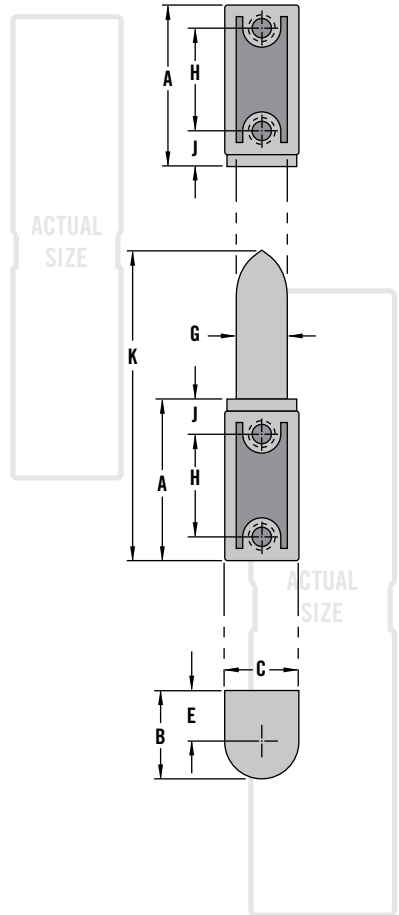

Offset Knuckle Style

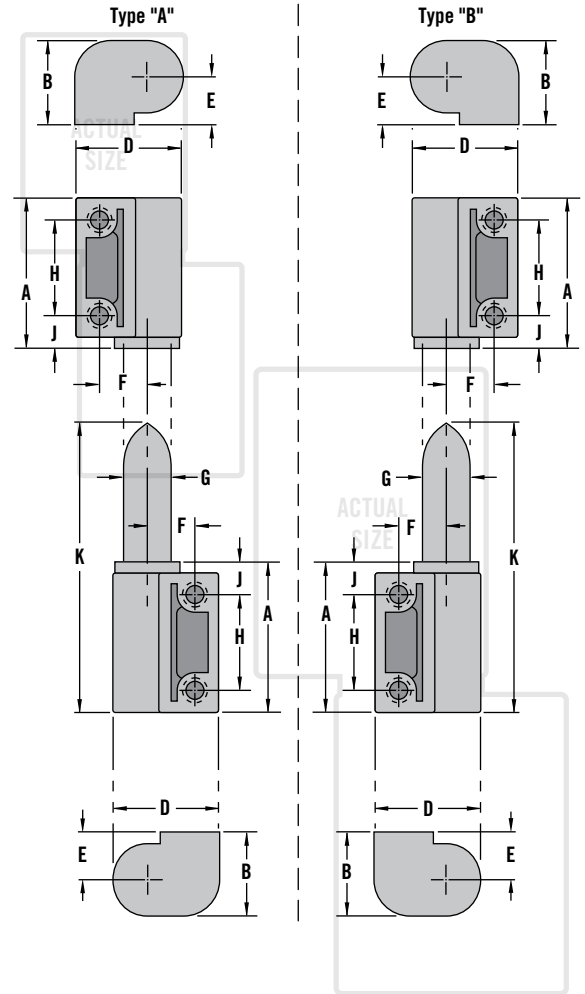

Mounting variations

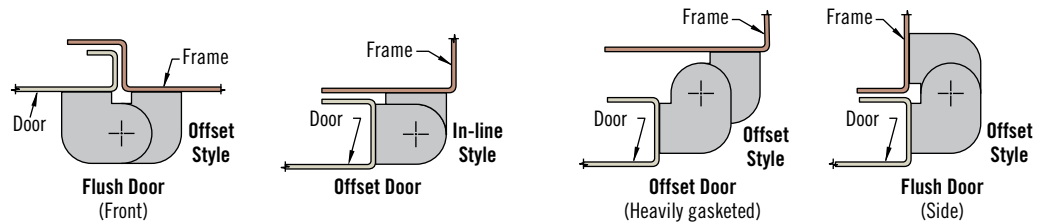

Part Number

See table

Series	Tapped Hole	Dimensions								Part Number		
		A	B	C	D	E, F & G	H	J	K	In-Line Knuckle Style	Offset Knuckle Style	
		Type "A"	Type "B"									
300	M5	31	16.7	14.3	21.5	9.5	19	7	58	96-50-300-11	96-50-310-11	96-50-320-11
	10-24	(1.22)	(.66)	(.56)	(.84)	(.38)	(.75)	(.28)	(2.28)	96-10-300-11	96-10-310-11	96-10-320-11
400	M6	41.3	22.2	19	28.5	12.7	25.5	9.5	78	96-50-400-11	96-50-410-11	96-50-420-11
	1/4-20	(1.63)	(.88)	(.75)	(1.13)	(.50)	(1.00)	(.38)	(3.06)	96-10-400-11	96-10-410-11	96-10-420-11

Dimensions in millimeters (inch) unless otherwise stated



www.southco.com/96

In-Line Knuckle Style

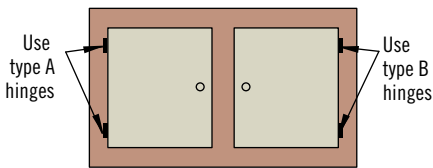
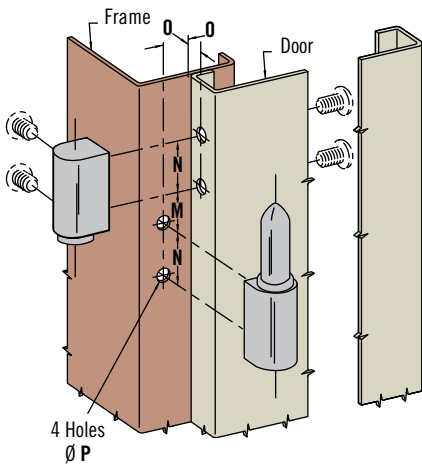
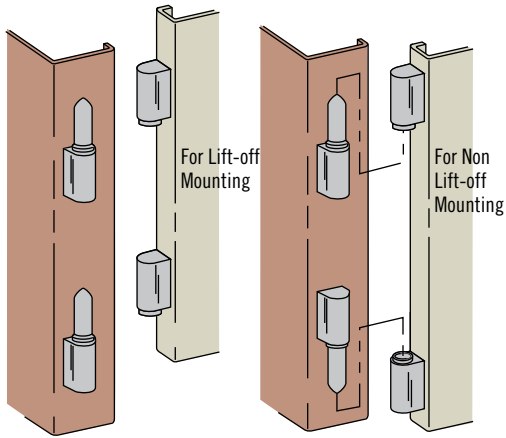

Offset Knuckle Style

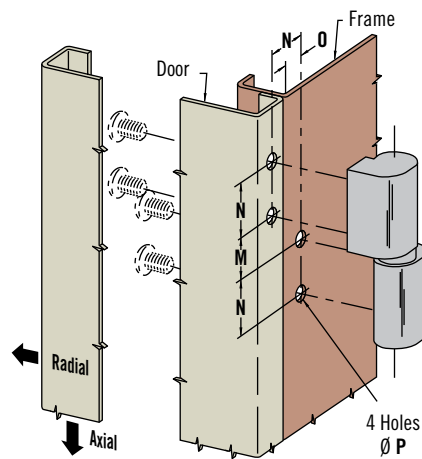
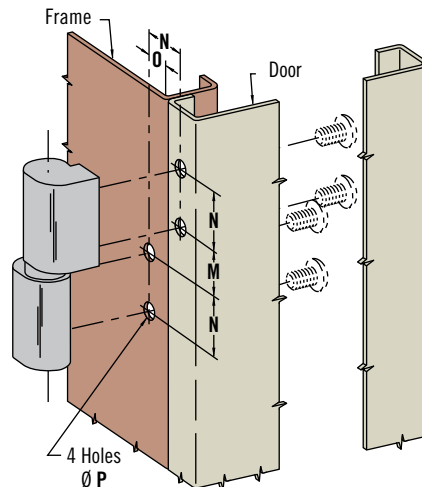
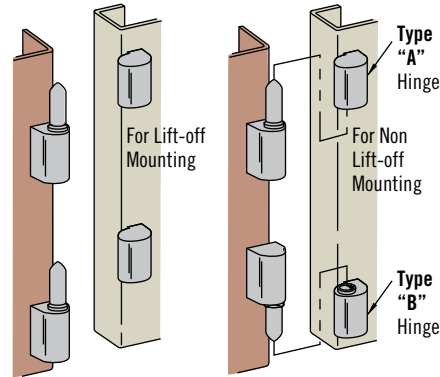

Installation Notes

Screws not supplied
 Max. tightening torque of screw:
 2.8 N·m (25 in·lbf)

Calculate screw length using the following formula:
 Door thickness + adjustment value

Series	Adjustment Value	
	In-Line	Offset
300	4.8 (.19)	6.5 (.25) Min. to 9.5 (.38) Max.
400	6.4 (.25)	9.5 (.38) Min. to 12.7 (.50) Max.

Series	Installation Dimensions			
	M	N	O	P
300	14.3 ^{+0.0} _{-0.3} (.563±.008)	19 ^{+0.2} _{-0.1} (.750±.008)	9.5 ^{+0.3} _{-0.1} (.375±.005)	5.4 ^{+0.1} _{-0.0} (.205 ^{+0.03} _{-0.000})
400	19.0 ^{+0.0} _{-0.3} (.750±.008)	25.5 ^{+0.1} _{-0.2} (1.000±.008)	12.7 ^{+0.2} _{-0.1} (.500±.005)	6.7 ^{+0.1} _{-0.0} (.264 ^{+0.03} _{-0.000})



96 Hinge

Lift-off · In-line · Plastic

- Allows for quick, easy door removal
- Door can also be permanently installed

Material and Finish

Black: Glass reinforced nylon
 Chrome: PC/ABS blend, chrome

Performance Details

Black	Radial Load	Axial Load
Max. static load	700 N (155 lbf)	1200 N (270 lbf)
Average Ultimate load	1000 N (224 lbf)	3500 N (785 lbf)

Chrome	Radial load	Axial load
Max. static load	350 N (79 lbf)	900 N (202 lbf)
Average ultimate load	600 N (135 lbf)	2200 N (495 lbf)

Installation Notes

Recommended tightening torque for mounting screws:
 1.6 N·m (14 in·lbf)

Offset mount preparation:
 To allow for 180° rotation A or B must be 8.5± (.33±.04)

Part Number

See table

Order pin, receiver and screws separately

Receiver

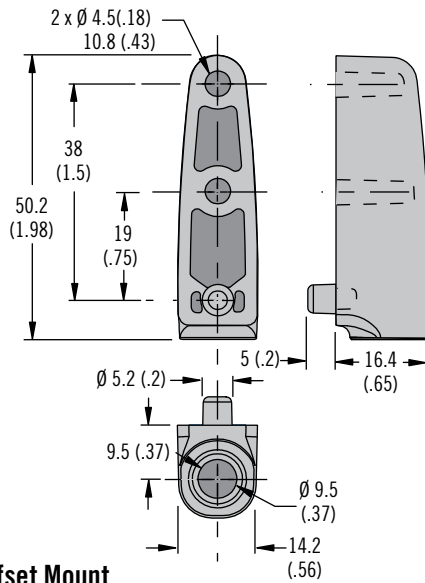

Offset Mount

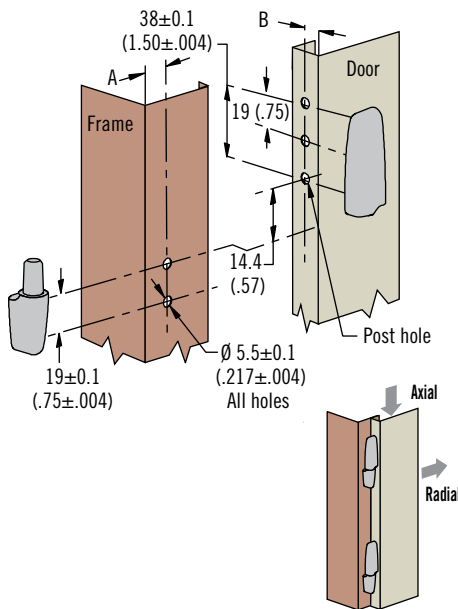

Pin

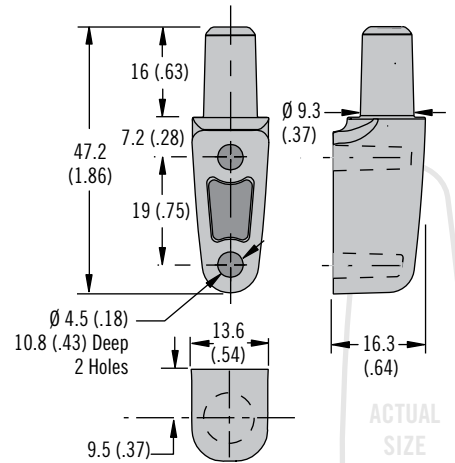

Flush Mount

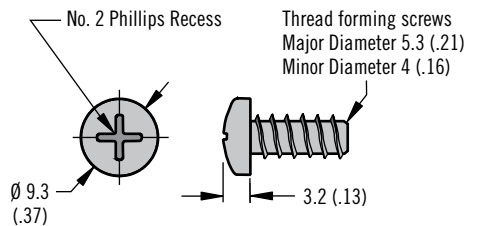
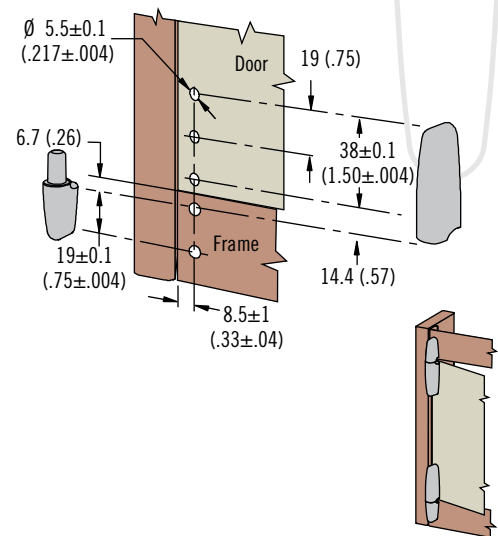

Door Thickness	Part Number
	Screws (4 per bag)
1 - 4 (.04 - .16)	96-79-1
4 - 7 (.16 - .28)	96-79-2
7 - 10 (.28 - .39)	96-79-3
10 - 13 (.39 - .51)	96-79-4

Finish	Part Number	
	Pin	Receiver
Black	96-710	96-720
Chrome	96-711	96-721

Dimensions in millimeters (inch) unless otherwise stated

96 Hinge

Lift-off · Adjustable compression · In-line · Zinc



Front Mount

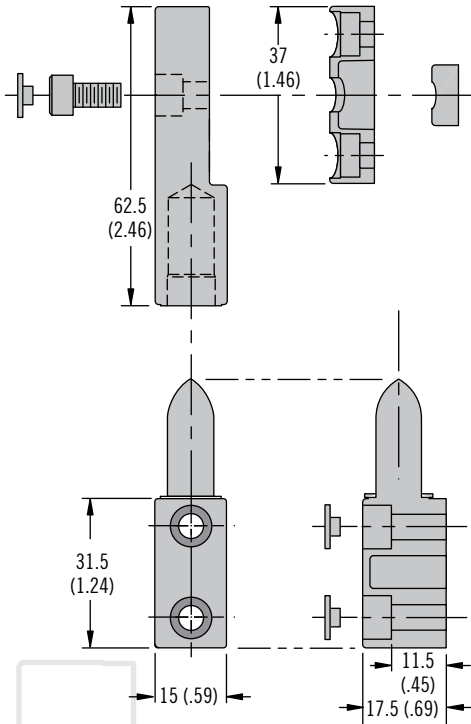

Concealed Mount

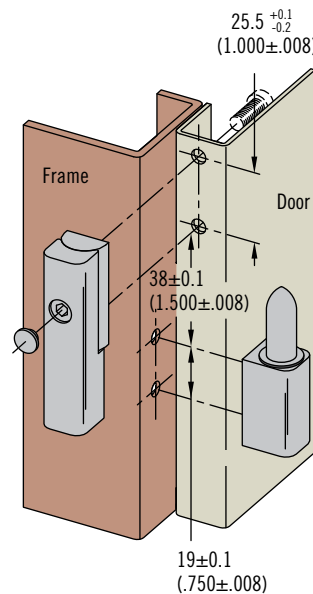
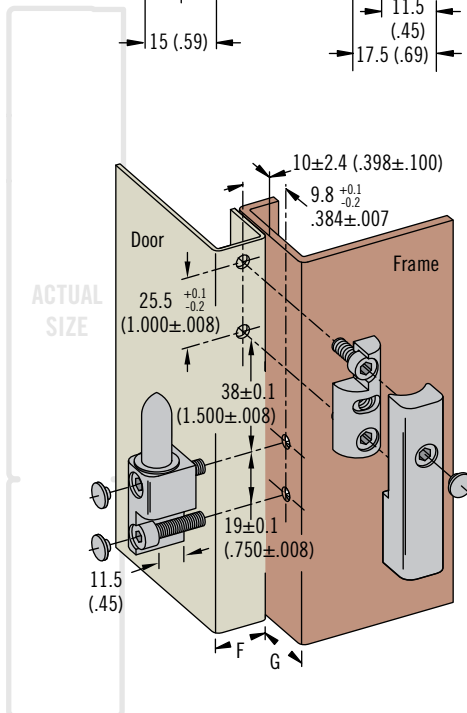
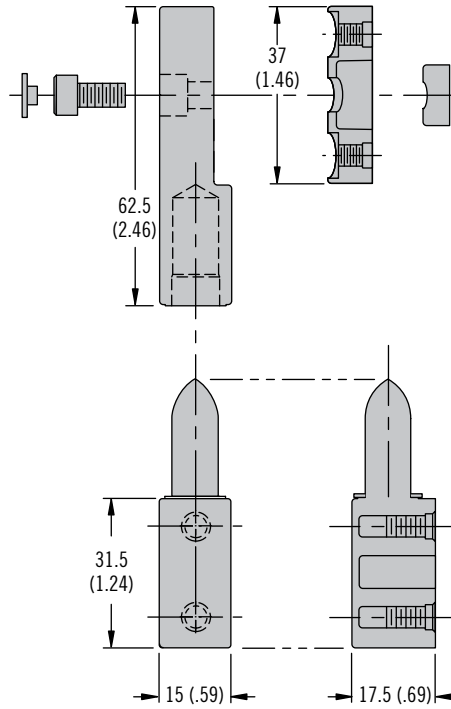

- Adjusts to ensure gasket compression
- Allows for quick, easy door removal



Material and Finish

Zinc alloy, black powder coated

Installation Notes

Screws not supplied.

Max. screw length equals door or frame thickness plus 7.5 (.30)

Performance Details

	Radial Load	Axial Load
Max. static load	1000 N (255 lbf)	2220 N (500 lbf)
Average ultimate load	1550 N (350 lbf)	14,000 N (3200 lbf)

Notes

Hinges provide 5 (.20) of total adjustment

Either F Dimension or G dimension must be less than 19.8 (.78) for the door to open a full 180°

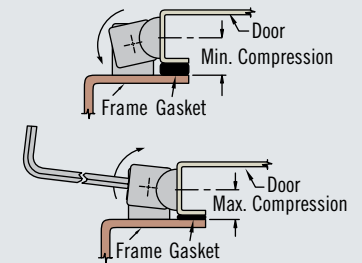

Install Style	Tapped Hole	Part Number
Front mount	Thru hole	96-10-572
Concealed mount	10-32 Imperial	96-10-570
	M5 x 0.8 Metric	96-50-570

Part Number

See table



96 Hinge

Lift-off · In-line · Zinc

- Allows for quick, easy door removal
- Concealed installation

Material and Finish

Zinc alloy, black powder coated

Performance Details

	Radial Load	Axial Load
Max. static load	1100 N (250 lbf)	1250 N (280 lbf)
Average ultimate load	2400 N (530 lbf)	2600 N (580 lbf)

Installation Notes

Screws not supplied.

Recommended tightening torque for mounting screws:

1.1 N·m (10 in·lbf)

Calculate screw length using the following formula:

Door / frame thickness +5 (.20)

In-Line

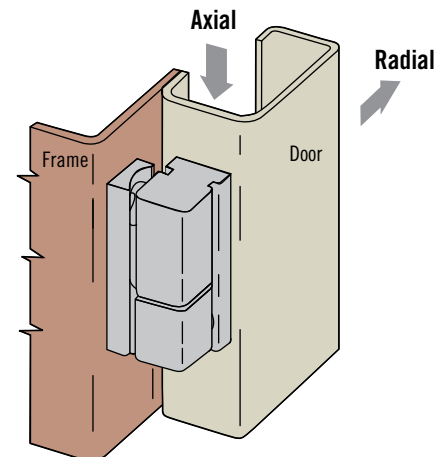
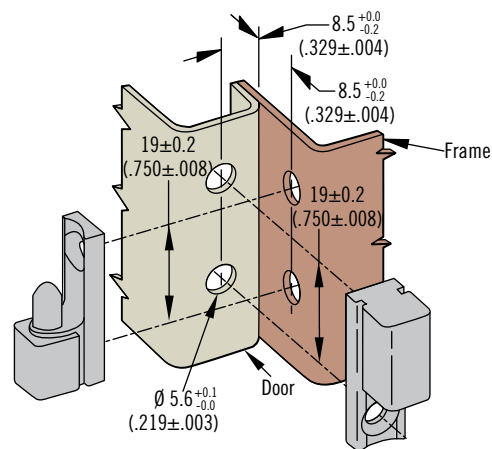
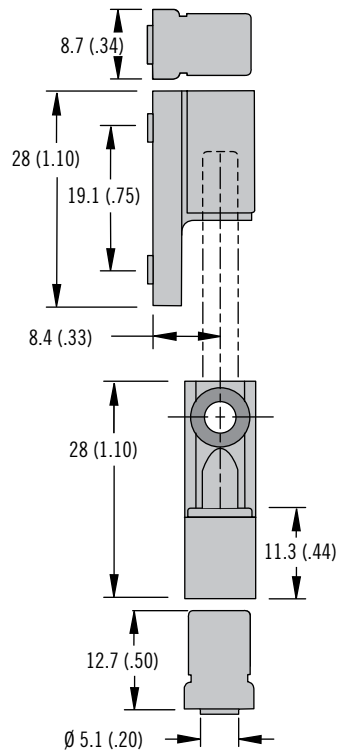

Part Number

See table

Tapped Hole	Part Number
Imperial 6-32	96-110
Metric M4 x 0.7	96-140

Dimensions in millimeters (inch) unless otherwise stated



www.southco.com/96

southco
CONNECT · CREATE · INNOVATE

96 Hinge

Lift-off · Offset · Zinc



Offset Type A

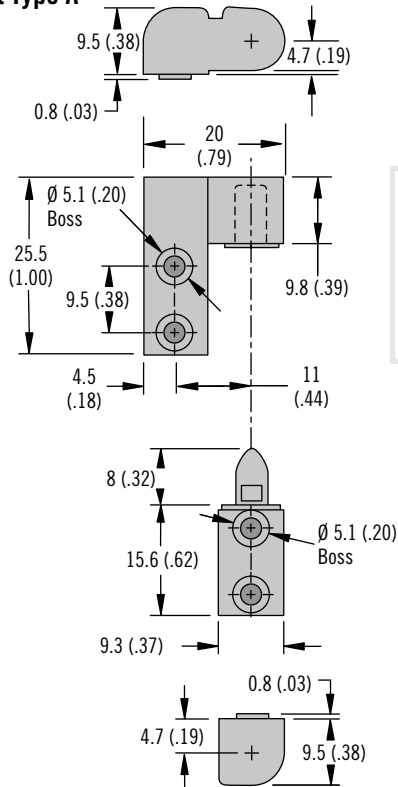

Offset Type B

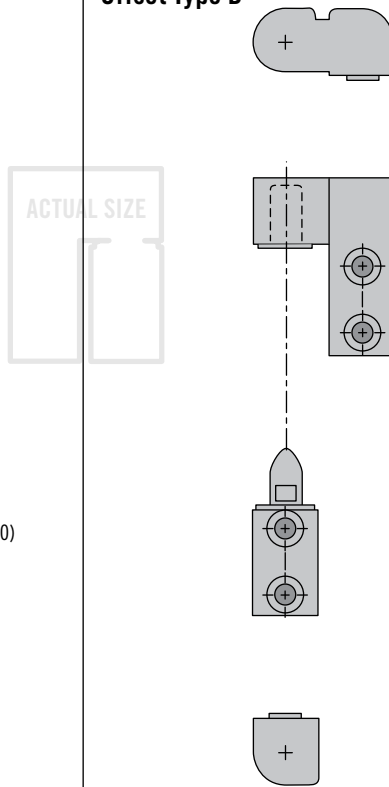

ACTUAL SIZE

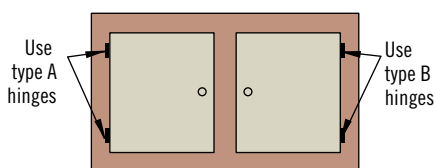
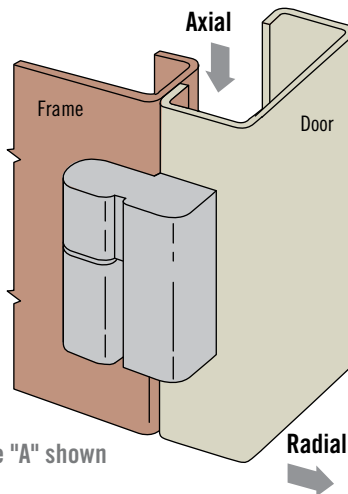
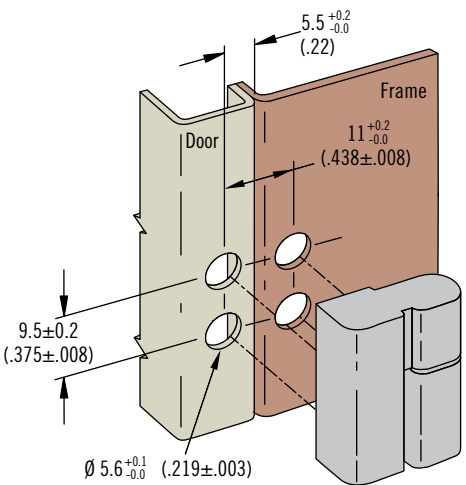

- Allows for quick, easy door removal
- Door can also be permanently installed

Material and Finish

Zinc alloy, black powder coated

Performance Details

	Radial Load	Axial Load
Max. static load	1100 N (250 lbf)	1250 N (280 lbf)
Average ultimate load	3300 N (750 lbf)	2600 N (580 lbf)

Installation Notes

Screws not supplied.

Recommended tightening torque for mounting screws:

1.1 N·m (10 in·lbf)

Calculate screw length using the following formula:

Door / frame thickness + 5 (.20)

Tapped Hole	Part Number	
	Type A	Type B
Imperial 6-32	96-111	96-112
Metric M4 x 0.7	96-141	96-142

Part Number

See table



96 Hinge

Lift-off

- Allows for quick, easy door removal
- All metal construction

Material and Finish

Steel, zinc plated or stainless steel

Type A

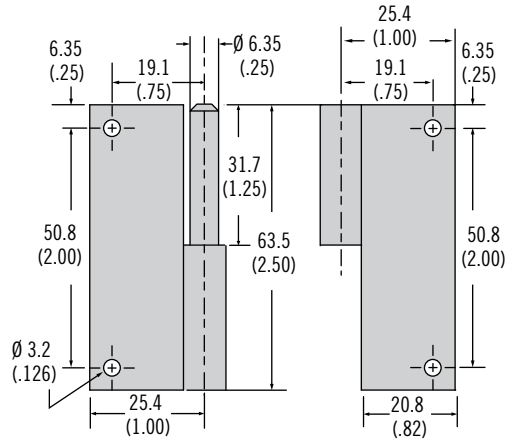

Type B

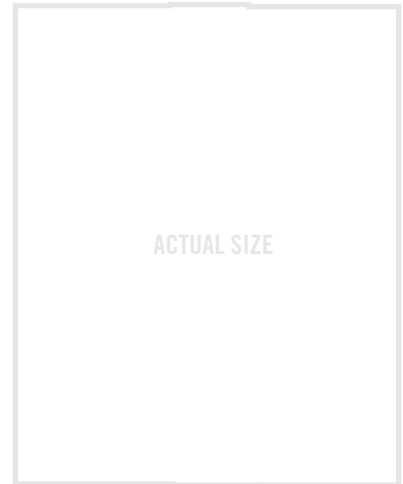
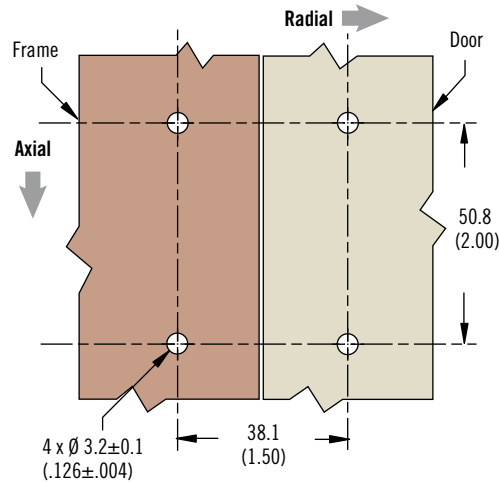
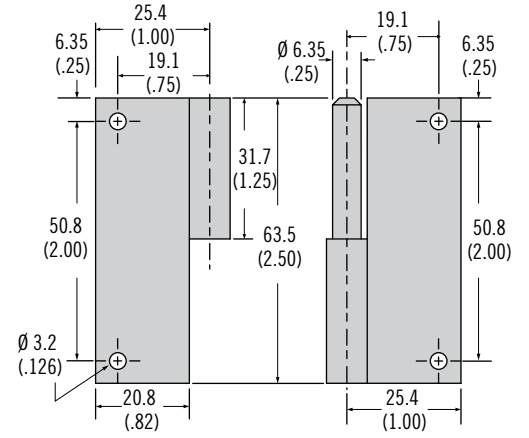

Type "A" application shown

Part Number

See table

Material	Part Number	
	Type A	Type B
Steel	96-04-N1WL	96-04-N1WR
Stainless Steel	96-04-S1WL	96-04-S1WR

Dimensions in millimeters (inch) unless otherwise stated



www.southco.com/96A