

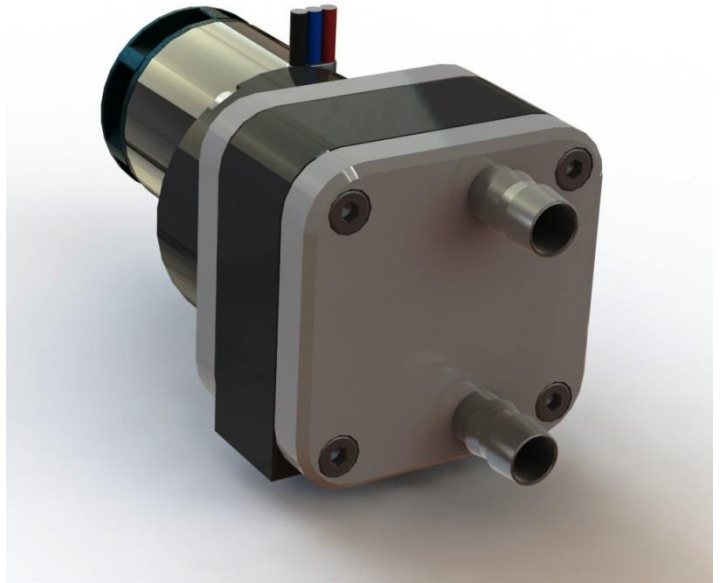

Professionally approved products.

Product Datasheet

RS VO30G High Flow Gas Pump

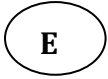



RS, Professionally Approved Products, gives you professional quality parts across all products categories. Our range has been testified by engineers as giving comparable quality to that of the leading brands without paying a premium price.

RS MG500S Micro-pump

The V030G miniature pump delivers vacuum or pressure of air with very large flow for its size. Smooth almost pulseless flow is driven by a powerful and controllable long life brushless motor. Flow is reversible using the appropriate electronic driver. Constructed from precision CNC machined parts of stainless steel, nylon 66 and Aluminium.

Standard features:

- Pressure + vacuum capability
- Large flow with small size
- Reversible flow
- Smooth almost pulseless flow
- Brushless drive
- Small size only 55 x 55 x 104 mm
- Weight 440g
- Wide range of chemical resistance
- Operating Temp -20 to 100 deg C
- IP Rating IP40
- Noise Levels 87dB (Measured at a distance of 1m with a 50dB ambient noise level)

Typical Applications

- Medical devices
- Analysis Systems
- Pressure vessels
- Cooling Systems
- Precision Flow
- Aerospace applications

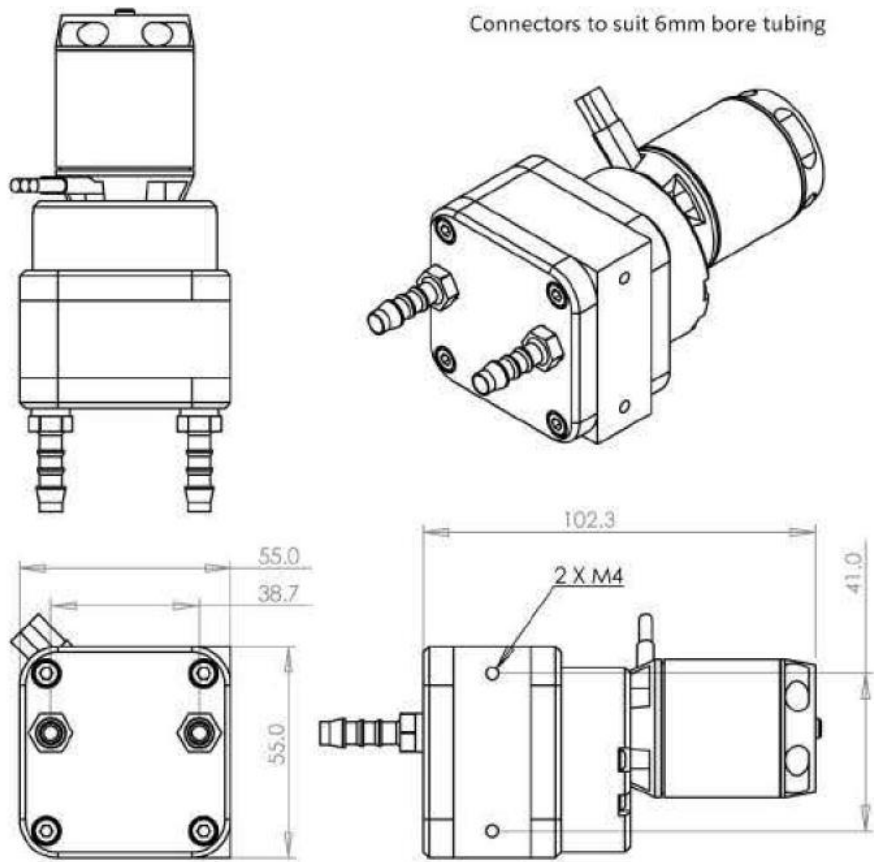

RS	MPN	Pump	Controller	Input (V)	Power (W)	Flow (LPM)	Pressure (psi)
8170810	V030G-12	V030G	EQ12	8	88	29	3.6
				12	166	43	8.5
8170813	V030G-24		EQ24	18	125	32	4
				24	168	42	6

Note Figures shown in **Red** are peak performance **ONLY**. For continuous use do not exceed the figures shown in Black.

Stock Number 8170801 requires a separate motor controller, 8170810 and 8170813 are fitted with controllers shown in the table above.

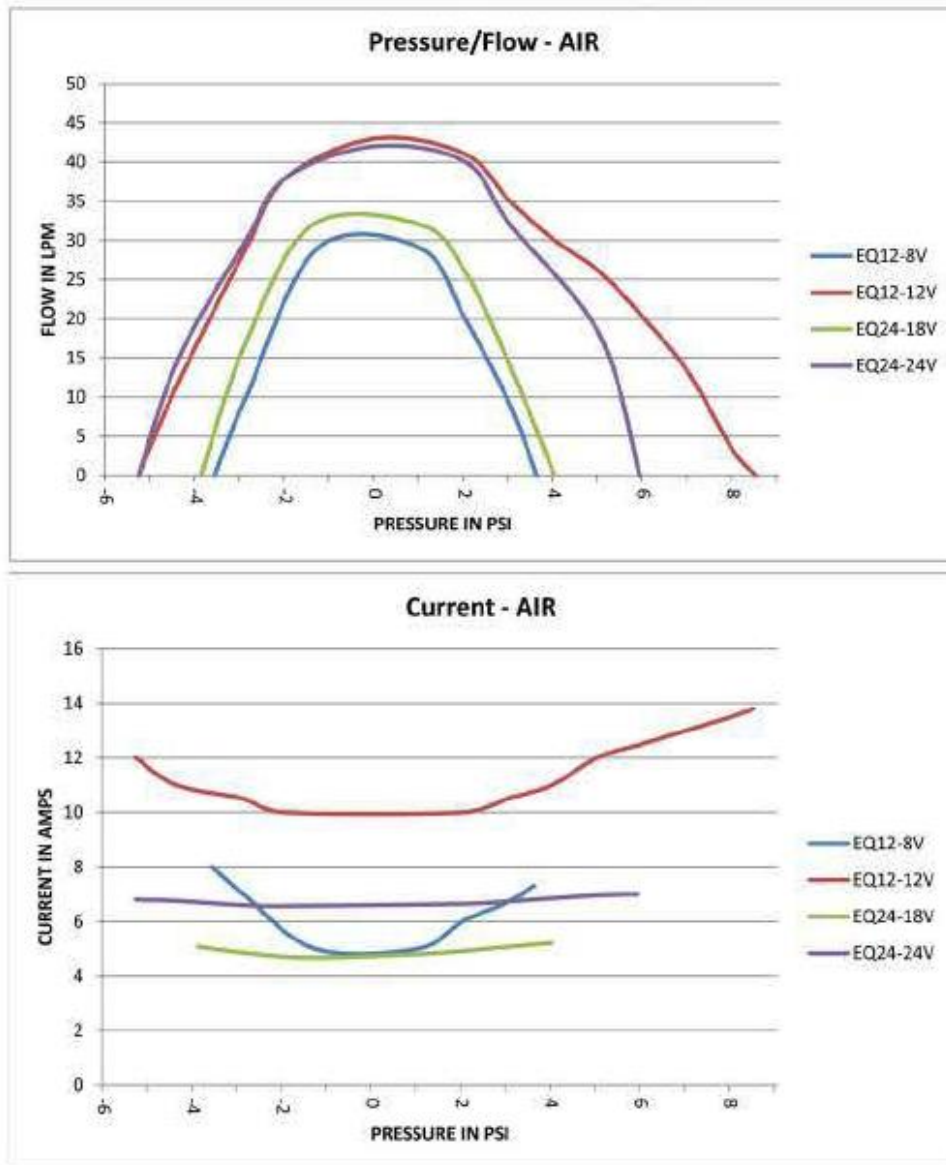

Note: The V030 pump range are not sealed and the gases being pumped may leak to atmosphere