

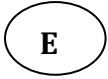

Professionally approved products.

Product Datasheet

RS MG500-Sub Submersible micro-pump





RS, Professionally Approved Products, gives you professional quality parts across all products categories. Our range has been testified by engineers as giving comparable quality to that of the leading brands without paying a premium price.

RS MG500-Sub Submersible Micro Pump

The MS500 series of pumps are driven by powerful brushless drive motors and can deliver unparalleled flow for their size. Constructed from precision CNC machined aluminium alloy with stainless steel tubing connectors and utilising a sea I-less pump design as standard. Optional seals, wetted part coatings and materials are also available enabling this pump range to suit most applications and resist most chemicals and solvents. The pump uses efficient push fit connectors designed for 8.0mm flexible tubing.

Standard features:

- Sealed waterproof design
- Sensor less, brushless drive motor
- CNC aluminium alloy construction
- Quiet pulseless smooth flow
- Free flow up to 10 litres per minute (water)
- Wide range of chemical resistance
- Small Size 64x 32 x 31mm
- Weight 100 -102 g
- Operating Temp -20 to 100 deg C
- IP Rating - Standard pumps IP67
- Noise Levels <15dB

Typical Applications

- Medical devices
- Fuel Cells
- Battery and Solar Powered Systems
- Cooling Systems
- Low Pressure Fuel Pump
- Lubrication systems

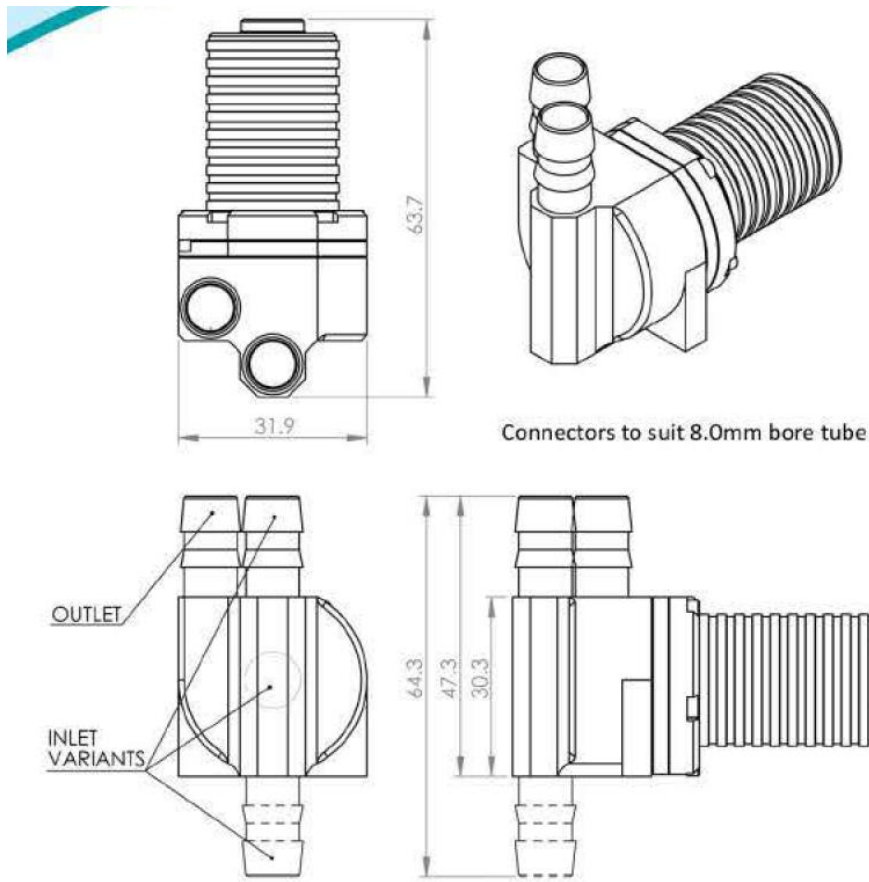

RS	MPN	Pump	Controller	Input (V)	Power (W)	Flow (LPM)	Pressure (mBar)
8170790	MG500S-Sub-12	MG500S	EQ12	6	6.5	3.4	69
				10	12.6	6.3	344
				12	15.6	8.0	482
8170794	MG500S-Sub-24	MG500S	EQ24	16	19.2	6.0	413
				18	22.8	7.0	517
				20	25.2	8.2	620
				24	32.4	10.0	861

Stock Number 8170781 requires a separate motor controller, 8170790 and 8170794 are fitted with controllers shown in the table above.



EQ12-M500

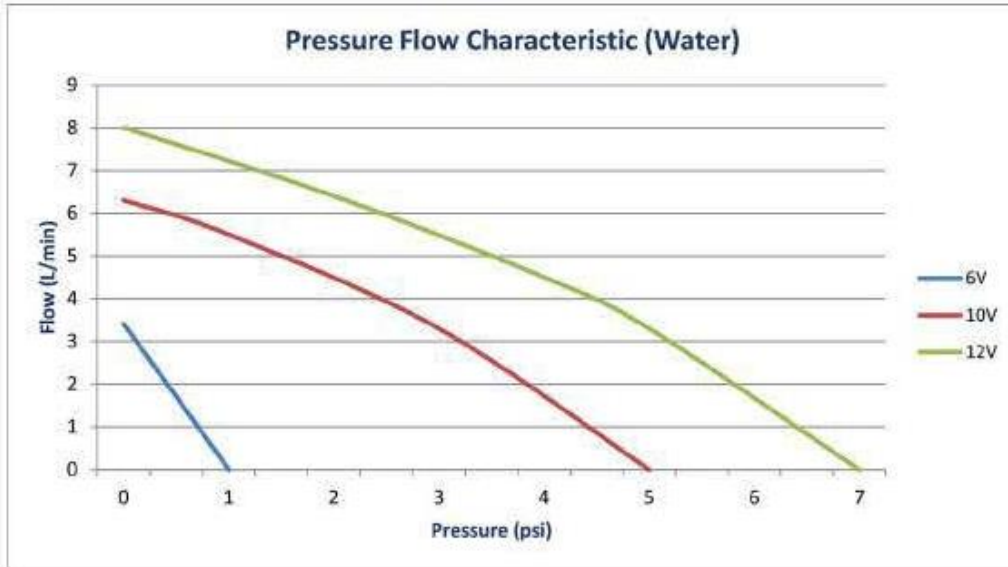

EQ24-M500

