



ENGLISH

Datasheet

RS Pro Centre Drills

BS Style: BS 328 / DIN 333A / ISO 866

RS Stock No: 408-7900

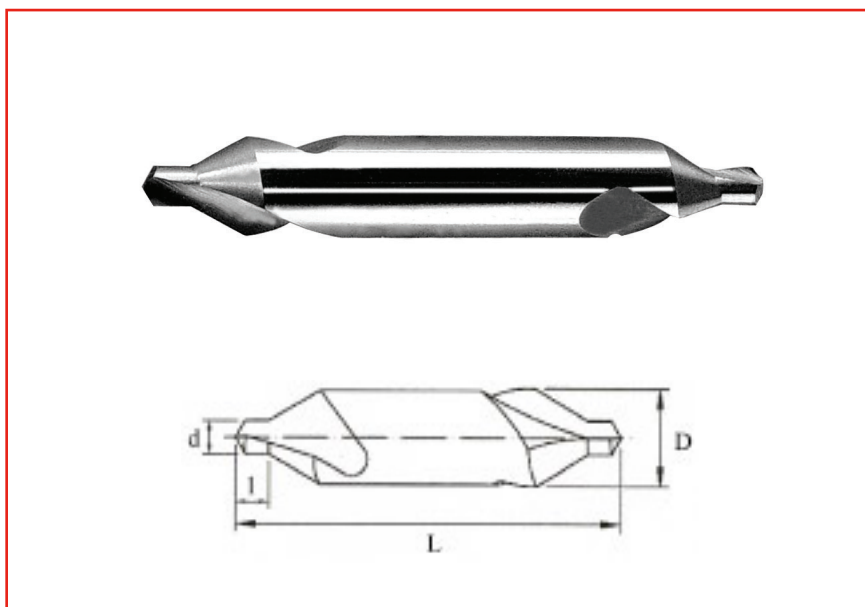

Specifications:

Produces conical centre holes in components which require machining between centres or a centre support to provide rigidity

Countersink angle: 60°

Point geometry: 120°

Right hand cutting

Silver finish

Supplied in plastic pack

| RS Code | Manufacturers Code | Size | d (inch) | D (inch) | i (inch) | L (inch) |
|---------|--------------------|------|----------|----------|----------|----------|
| \ | 22-100-001 | BS1 | 3/64 | 1/8 | 3/32 | 1-1/2 |