

## Stud Type Track Rollers

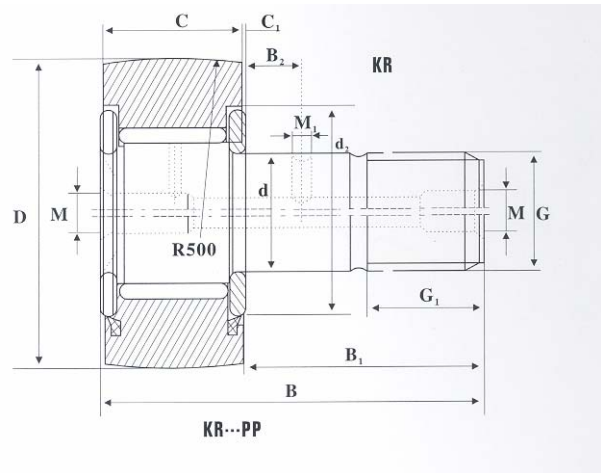

RS article No.	Boundary Dimensions (mm)											
	D	d	C	B	B1	B2	G	G1	M	M1	C1	d2
471304	16	6	11	28	16	-	M6	8	4	-	0.6	12
471314	19	8	11	32	20	-	M8	10	4	-	0.6	14
471320	22	10	12	36	23	-	M10 X 1	12	4	-	0.6	17
471310	26	10	12	36	23	-	M10 X 1	12	4	-	0.6	17
471348	30	12	14	40	25	6	M12 X 1.5	13	6	3	0.6	23
471358	32	12	14	40	25	6	M12 X 1.5	13	6	3	0.6	23
471354	35	16	18	52	32.5	8	M16 X 1.5	17	6	3	0.8	27

Stock No.	Bore Size (mm)	Roller Diameter (mm)	Length (mm)	Maximum Load-Dynamic (N)	Maximum Load-Static (N)	Maximum Speed-Grease (rpm)	Maximum Speed-Oil (rpm)
471304	28	16	11	3700	3800	11200	16,000
471314	32	19	11	4250	4600	9880	14,000
471320	36	22	23	5700	6500	7700	11,000
471310	36	26	12	5700	6500	7700	11,000
471348	40	30	14	8100	9700	5810	8,300
471358	40	32	14	8100	9700	5810	8,300
471354	52	35	18	12900	19000	4900	7,000