



# Solid State Relays 3-Phase with Integrated Heatsink Types RGC2, RGC3



- 2-pole & 3-pole switching AC solid state contactors
- Product width up to 70mm
- Rated operational voltage: up to 660VAC
- Rated operational current: up to 75AAC
- Control voltages: 5-32VDC, 20-275VAC (24-190 VDC)
- Up to 15,000A<sup>2</sup>s for I<sup>2</sup>t
- Motor ratings up to 11 kW @ 400VAC, 25HP @ 600VAC
- Integrated varistor protection on output
- Optional monitoring for SSR and load malfunction (RGC..M)<sup>1</sup>
- EMR alarm output and auxiliary output (RGC..M)
- Controlled fan operation for versions with integrated fan
- 100kA Short Circuit Current Rating according to UL508
- DIN or panel mount



1: RGC..M is suitable only for resistive loads  
2: Applicable only to RGC...10

## Product Description

This product is intended to replace mechanical contactors especially when switching is frequent. The smallest product width in the RGC2, RGC3 range is 54mm (3xDIN) and goes up to 70mm. 2-pole and 3-pole switching options are available.

Apart from resistive and slightly inductive loads, the RGC is certified for motor switching with associated motor ratings. A green LED gives indication of control voltage presence. Fan

operation is controlled for the versions which have an integrated fan.

Detection of SSR overheating, mains loss, SSR malfunction and load loss is possible with the RGC..M versions. An EMR alarm output is available for remote signaling. An additional feature with the RGC..M is the electronic auxiliary output. The RGC..M has additional LEDs for load status and alarm status indication.

## Ordering Key **RGC 3 A 60 D 65 G G E D F M**

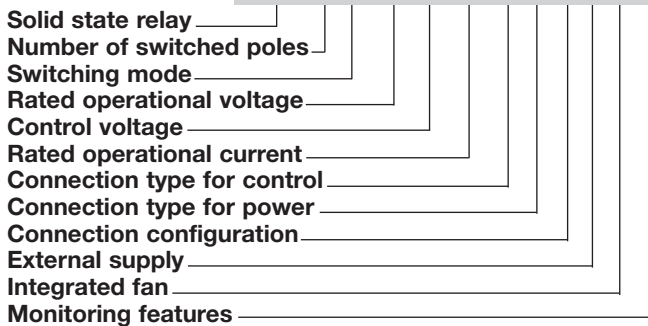

Specifications are at a surrounding temperature of 25°C unless otherwise specified.

## Ordering Key (refer to page 2 for available part nos.)

SSR with heatsink	Rated voltage (Ue) <sup>5</sup> , Blocking voltage	Control voltage <sup>6</sup> (Uc)	Rated current/pole @40°C <sup>3</sup>	Connection control	Connection power	Connection configuration	External supply (Us)	Features
RGC2A: 2-pole switching + 1-pole direct, ZC	22: 42-242VAC, 800Vp  60: 42-660VAC, 1200Vp	D: 5 - 32VDC  A: 20-275VAC, 24-190VDC	10: 10AAC 25: 25AAC 40: 40AAC 75: 75AAC	K: Screw G: Box Clamp	K: Screw G: Box Clamp	E: Contactor	D: 24VDC A: 90-250VAC	F: Integrated fan with over temperature protection (OTP) & EMR alarm output  M: Monitoring for Mains loss, Load loss, SSR short circuit, open circuit and over-temperature with EMR alarm output and auxiliary output <sup>1</sup>
RGC3A: 3-pole switching ZC <sup>4</sup>	22: 42-242VAC, 800Vp  60: 42-660VAC, 1200Vp	D: 5 - 32VDC  A: 20-275VAC, 24-190VDC	10: 10AAC 20: 20AAC 25: 25AAC 30: 30AAC 40: 40AAC 65: 65AAC	K: Screw G: Box Clamp	K: Screw G: Box Clamp	E: Contactor	D: 24VDC A: 90-250VAC	F: Integrated fan with over temperature protection (OTP) & EMR alarm output  M: Monitoring for Mains loss, Load loss, SSR short circuit, open circuit and over-temperature with EMR alarm output and auxiliary output <sup>1</sup> (suitable only for resistive loads)

3. Refer to Current Derating curves

4. ZC= Zero Cross Switching

5. Operating voltage for RGC..M starts from 90VAC

6. AC control range for RGC..A.. is limited to 20-275VAC only

## Selection Guide: RGC2 (2-pole switching, 1-pole direct)

Rated output voltage, Ue	Control voltage, Uc	Features	External supply, Us	Rated operational current @ 40°C (I <sup>2t</sup> )					
				Product width					
				10 AAC/pole (1,800A <sup>2</sup> s) 54mm	25 AAC/pole (1,800A <sup>2</sup> s) 54mm	-	40 AAC/pole (6,600A <sup>2</sup> s) 70mm	-	75 AAC/pole (15,000A <sup>2</sup> s) 70mm + fan
220 VAC	5-32 VDC	-	-	-	RGC2A22D25KKE	-	-	-	-
	20-275 VAC, 24-190 VDC	-	-	-	RGC2A22A25KKE	-	-	-	-
600 VAC	5-32 VDC	-	-	RGC2A60D10KKE	RGC2A60D25KKE	-	RGC2A60D40KGE	-	-
		OTP	24 VDC	-	-	-	-	-	RGC2A60D75GGEDF
	OTP	90-250 VAC	-	-	-	-	-	RGC2A60D75GGGEAF	
	20-275 VAC, 24-190 VDC	-	-	RGC2A60A10KKE	RGC2A60A25KKE	-	RGC2A60A40KGE	-	-
	20-275 VAC	OTP	90-250 VAC	-	-	-	-	-	RGC2A60A75GGGEAF

## Selection Guide: RGC3 (3-pole switching)

Rated output voltage, Ue	Control voltage, Uc	Features	External supply, Us	Rated operational current @ 40°C (I <sup>2t</sup> )					
				Product width					
				10 AAC/pole (1,800A <sup>2</sup> s) 54mm	20 AAC/pole (1,800A <sup>2</sup> s) 54mm	25 AAC/pole (1,800A <sup>2</sup> s) 70mm	30 AAC/pole (6,600A <sup>2</sup> s) 70mm	40 AAC/pole (6,600A <sup>2</sup> s) 54mm + fan	65 AAC/pole (15,000A <sup>2</sup> s) 70mm + fan
220VAC	5-32 VDC	-	-	RGC3A22D10KKE	RGC3A22D20KKE	-	-	-	-
	20-275 VAC, 24-190 VDC	-	-	RGC3A22A10KKE	RGC3A22A20KKE	-	-	-	-
600VAC	5-32 VDC	-	-	RGC3A60D10KKE	RGC3A60D20KKE	RGC3A60D25KKE	RGC3A60D30KGE	-	-
		OTP	24VDC	-	-	-	-	RGC3A60D40GGEDF	RGC3A60D65GGEDF
	OTP	90-250VAC	-	-	-	-	-	RGC3A60D65GGGEAF	
	20-275 VAC, 24-190 VDC	-	-	RGC3A60A10KKE	RGC3A60A20KKE	RGC3A60A25KKE	RGC3A60A30KGE	-	-
	20-275 VAC	OTP	90-250VAC	-	-	-	-	RGC3A60A40GGGEAF	RGC3A60A65GGGEAF

## Selection Guide: RGC2..M (2-pole switching, 1-pole direct with monitoring)

Rated output voltage, Ue	Control voltage, Uc	Features	External supply, Us	Rated operational current @ 40°C (I <sup>2t</sup> )					
				Product width					
				-	25 AAC /pole (1,800A <sup>2</sup> s) 54mm	-	40 AAC /pole (6,600A <sup>2</sup> s) 70mm	-	75 AAC /pole (15,000A <sup>2</sup> s) 70mm + fan
600 VAC	5-32 VDC	Monitoring	24 VDC	-	RGC2A60D25GKEDM	-	RGC2A60D40GGEDM	-	RGC2A60D75GGEDFM
		Monitoring	90-250 VAC	-	RGC2A60D25GKEAM	-	RGC2A60D40GGGEAM	-	RGC2A60D75GGGEAFM
	20-275 VAC	Monitoring	90-250 VAC	-	RGC2A60A25GKEAM	-	RGC2A60A40GGGEAM	-	RGC2A60A75GGGEAFM

## Selection Guide: RGC3..M (3-pole switching with monitoring)

Rated output voltage, Ue	Control voltage, Uc	Features	External supply, Us	Rated operational current @ 40°C (I <sup>2t</sup> )					
				Product width					
				-	20 AAC /pole (1,800A <sup>2</sup> s) 54mm	25 AAC /pole (1,800A <sup>2</sup> s) 70mm	30 AAC /pole (6,600A <sup>2</sup> s) 70mm	-	65 AAC /pole (15,000A <sup>2</sup> s) 70mm + fan
600VAC	5-32VDC	Monitoring	24 VDC	-	RGC3A60D20GKEDM	RGC3A60D25GKEDM	RGC3A60D30GGEDM	-	RGC3A60D65GGEDFM
		Monitoring	90-250 VAC	-	RGC3A60D20GKEAM	RGC3A60D25GKEAM	RGC3A60D30GGGEAM	-	RGC3A60D65GGGEAFM
	20-275VAC	Monitoring	90-250 VAC	-	RGC3A60A20GKEAM	RGC3A60A25GKEAM	RGC3A60A30GGGEAM	-	RGC3A60A65GGGEAFM

KKE: input terminals = screw, output terminals = screw  
 KGE: input terminals = screw, output terminals = box clamp

GKE: input terminals = box clamps, output terminals = screw  
 GGE: input terminals = box clamps, output terminals = box clamp

## General Specifications

	RGC	RGC..M
Latching voltage (across each pole L-T)	<20V	<20V
Operational frequency range	45 to 65Hz	45 to 65Hz
Power factor	>0.5 at rated voltage	>0.5 at rated voltage
CE marking	Yes	Yes
Touch protection	IP20	IP20
LED status indication	Control ON Supply ON Load ON Alarm ON	Green, full intensity Green, half intensity ( <b>RGC..F</b> ) - Red, full intensity ( <b>RGC..F</b> )
		Green, full intensity Green, half intensity Yellow, full intensity Red, flashing <sup>7</sup>
Pollution degree	2 (non-conductive pollution with possibilities of condensation)	2 (non-conductive pollution with possibilities of condensation)
Over-voltage category	III (fixed installations), 6kV (1.2/50µs) rated impulse withstand voltage Uimp	III (fixed installations), 6kV (1.2/50µs) rated impulse withstand voltage Uimp
Isolation	Input & Output to Case Input to Output	4000Vrms 4000Vrms
		4000Vrms 2500Vrms

7: Refer to Red LED Alarm Indications

## Output Voltage Specifications

	RGC	RGC..22	RGC..60
Operational voltage range, U <sub>e</sub>	RGC..M	42-220VAC, -15%/+10% on max	42-600VAC, -15%/+10% on max
		-	90-600VAC, -15%/+10% on max
Blocking voltage		800Vp	1200Vp
Internal varistors (across each pole)		275V	625V

## Output Specifications: RGC2

	RGC2..10	RGC2..25	RGC2..40	RGC2..75
Rated operational current per pole <sup>8</sup>				
AC-51 @ Ta=25°C	10 AAC	32 AAC	50 AAC	85 AAC
AC-51 @ Ta=40°C	10 AAC	27 AAC	40 AAC	75 AAC
AC-53a @ Ta=40°C	5 AAC	11.5 AAC	16.5 AAC	28 AAC
No. of motor starts per hour <sup>9</sup> (x: 6, Tx:6s, F:50%) @ 40°C	10	30	30	30
Minimum operational current	250 mAAC	250 mAAC	400 mAAC	500 mAAC
RGC..F, RGC..M	-	1.2 AAC	1.2 AAC	1.2 AAC
Maximum off-state leakage current	5 mAAC	5 mAAC	5 mAAC	5 mAAC
Rep. overload current (Motor rating) UL508: Ta=40°C, t <sub>ON</sub> =1s, t <sub>OFF</sub> =9s, 50 cycles	30 AAC	61 AAC	107 AAC	154 AAC
Maximum transient surge current (I <sub>TSM</sub> ), t=10ms	600 Ap	600 Ap	1150 Ap	1750 Ap
I <sup>2</sup> t for fusing (t=10ms), minimum	1800 A <sup>2</sup> s	1800 A <sup>2</sup> s	6600 A <sup>2</sup> s	15000 A <sup>2</sup> s
Critical dv/dt (@ T <sub>j</sub> init = 40°C)	1000 V/µs	1000 V/µs	1000 V/µs	1000 V/µs

8: Refer to Current Derating Curves. Max. VDE AC-51 rating for RGC2..10 is 9AAC

9: Overload profile for AC-53a;

le: AC-53a: xle-Tx: F-S, where le = nominal current (AC-53a AAC), xle = overload current (AAC), Tx = duration of overload current (s), F = duty cycle (%), S = number of starts. Example; 5A: AC-53a: 30 - 6 : 50 - 10 = max. 10 starts for the RGC2..10 with an overload profile of 30A for 6 seconds with a duty cycle of 50%.

## Output Specifications: RGC3

	RGC30..10	RGC3..20	RGC3..25	RGC3..30	RGC3..40	RGC3..65
Rated operational current per pole <sup>8</sup> AC-51 @ Ta=25°C	10 AAC	25 AAC	32 AAC	37 AAC	42 AAC	71 AAC
AC-51 @ Ta=40°C	10 AAC	20 AAC	28 AAC	30 AAC	42 AAC	66 AAC
AC-53a @ Ta=40°C	5 AAC	10 AAC	11 AAC	14 AAC	17 AAC	25 AAC
No. of motor starts per hour <sup>9</sup> (x: 6, Tx:6s, F:50%) @ 40°C	10	30	30	30	30	30
Minimum operational current RGC..F, RGC..M	250 mAAC -	250 mAAC 1.2 AAC	250 mAAC 1.2 AAC	400 mAAC 1.2 AAC	400 mAAC 1.2 AAC	500 mAAC 1.2AAC
Maximum Off-state leakage current	5 mAAC	5 mAAC	5 mAAC	5 mAAC	5 mAAC	5 mAAC
Rep. overload current (Motor rating) UL508: Ta=40°C, t <sub>ON</sub> =1s, t <sub>OFF</sub> =9s, 50 cycles	30 AAC	61 AAC	84 AAC	107 AAC	107 AAC	154 AAC
Maximum transient surge current (I <sub>TSM</sub> ), t=10ms	600 Ap	600 Ap	600 Ap	1150 Ap	1150 Ap	1750 Ap
I <sup>2</sup> t for fusing (t=10ms), minimum	1800 A <sup>2</sup> s	1800 A <sup>2</sup> s	1800 A <sup>2</sup> s	6600 A <sup>2</sup> s	6600 A <sup>2</sup> s	15000 A <sup>2</sup> s
Critical dv/dt (@ T <sub>j</sub> init = 40°C)	1000 V/μs	1000 V/μs	1000 V/μs	1000 V/μs	1000 V/μs	1000 V/μs

8: Refer to Current Derating curves. Max VDE AC-51 rating for RGC3..10 is 9AAC

## Motor Ratings: HP (UL508) / kW (EN/IEC 60947-4-2) @ 40°C

	115VAC	230VAC	400VAC	480VAC	600VAC
RGC2..10	½HP / 0.37 kW	1HP / 1.1 kW	2HP / 1.5 kW	3HP / 2.2 kW	3HP / 3 kW
RGC2..25	1½HP / 1.1 kW	3HP / 3.0 kW	5HP / 5.5 kW	7½HP / 5.5 kW	10HP / 9.0 kW
RGC2..40	3HP / 1.5 kW	5HP / 4.0 kW	10HP / 7.5 kW	10HP / 9.0 kW	15HP / 11.0 kW
RGC2..75	5HP / 3.0 kW	10HP / 7.5 kW	15HP / 11.0 kW	20HP / 15.0 kW	25HP / 22.0 kW
RGC3..10	½HP / 0.37 kW	1HP / 1.1 kW	2HP / 1.5 kW	3HP / 2.2 kW	3HP / 3 kW
RGC3..20	1HP / 0.75 kW	3HP / 2.2 kW	5HP / 4.0 kW	7½HP / 5.5 kW	10HP / 7.5 kW
RGC3..25	2HP / 1.1 kW	3HP / 2.2 kW	7½HP / 4.0 kW	10HP / 5.5 kW	10HP / 7.5 kW
RGC3..30	2HP / 1.5 kW	5HP / 3.0 kW	10HP / 5.5 kW	10HP / 7.5 kW	15HP / 11.0 kW
RGC3..40	2HP / 1.5 kW	5HP / 4.0 kW	10HP / 7.5 kW	10HP / 9.0 kW	15HP / 11.0 kW
RGC3..65	3HP / 3.0 kW	10HP / 5.5 kW	15HP / 11.0 kW	20HP / 15.0 kW	25HP / 20.0 kW

## Control Specifications (A1, A2)

	RG..D..	RG..A..
Control voltage range, U <sub>c</sub>	5 - 32 VDC	20-275 VAC, 24 (-10%) -190 VDC
Pick-up voltage	4.8 VDC	20 VAC/DC
Drop-out voltage	1.0 VDC	5 VAC/DC
Maximum reverse voltage	32 VDC	-
Maximum response time	0.5 cycle + 500us @ 24 VDC	2 cycles @ 230 VAC/110 VDC
Input current @ 40°C	see diagrams below	see diagrams below

## Control Specifications (A1, A2) for RGC..F, RGC..M

	RG..D..D.. RG..D..A..	RG..A..A..
Control voltage range, U <sub>c</sub>	5 - 32 VDC	20-275 VAC
Pick-up voltage	4.8 VDC	20 VAC
Drop-out voltage	1.0 VDC	5 VAC
Maximum reverse voltage	32 VDC	-
Maximum response time	1 cycle + 500us @ 24 VDC	5 cycles @ 230 VAC
Input current @ 40°C	see diagrams below	see diagrams below

### RG..D

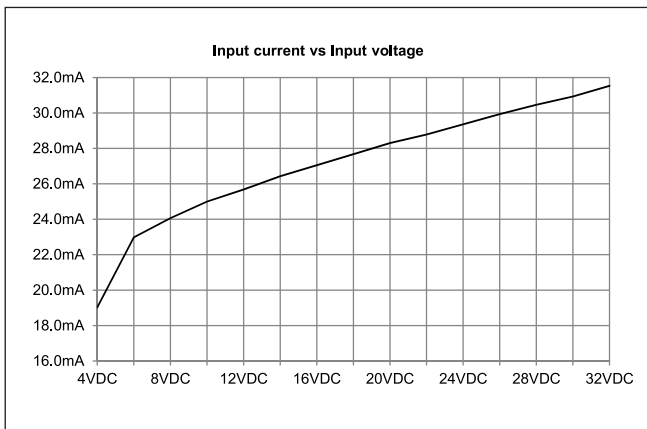

### RG..A

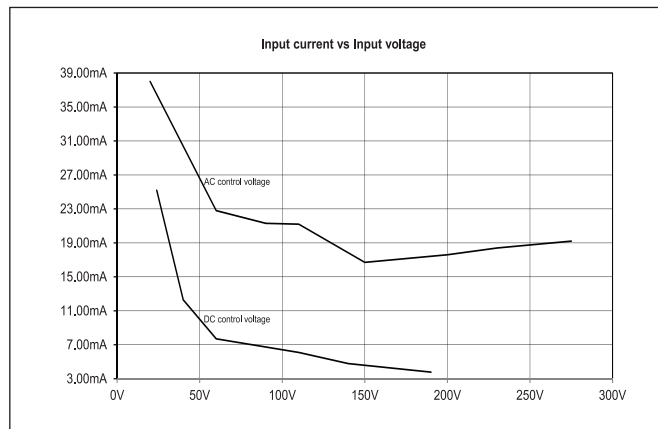

### RG..D..D.., RG..D..A..

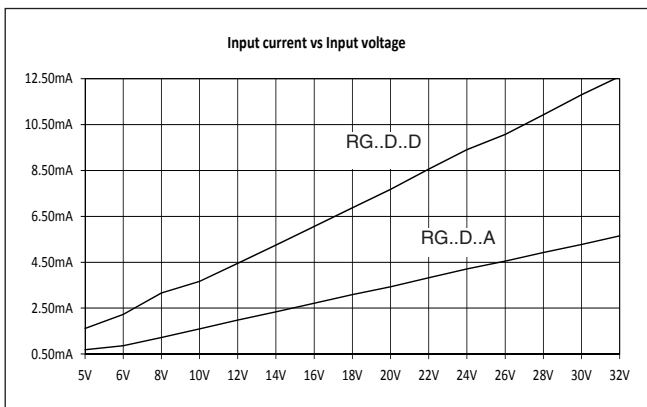

### RG..A..A..

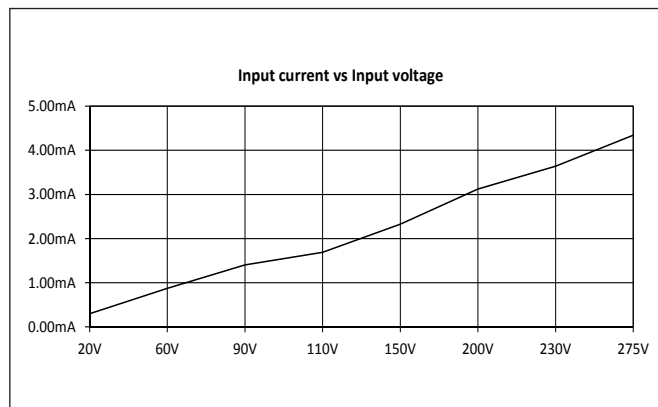

## Supply Specifications (Us)

	RG..D..D..	RG..D..A.. RG..A..A..
Supply voltage range, U <sub>s</sub>	24 VDC, -15% / +20%	90-250 VAC
Reverse protection	Yes	n/a
Surge protection <sup>10</sup>	500V PC1 with integrated transil	L-L 1kV, L-E 2kV PC1 <sup>10, 11</sup>
Max. supply current		
no fan, RG..M	80 mA	60 mA
with fan, RG..F, RG..FM	150 mA	80 mA

10. Refer to Electromagnetic Compatibility section for further details

11. When supplied from secondary circuit with short circuit limit of 1500VA



## Alarm Specifications (12, 14, 11)

	<b>RG..F</b> <b>RG..M</b>
Output type	EMR, 1 Form C (SPDT) Normally closed (12-11) Normally open (14-11)
Contact rating	2A @ 250VAC / 30VDC
Isolation between open contacts	1000VAC

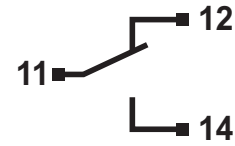

## Auxiliary Output Specifications (22, 24, 21)

	<b>RG..D..D..</b> <b>RG..D..A..</b>	<b>RG..A..A..</b>
Output type	PNP darlington, Normally closed (22-21) NPN darlington, Normally open (24-21)	Triac, Normally closed (22-21) Triac, Normally open (24-21)
Rated voltage	24VDC +/-20%	90-250VAC
On-state voltage drop Typical	4VDC	< 2VAC
Blocking voltage	-	800Vp
Maximum current rating	50mADC	1AAC @ 25°C <sup>12</sup>
Delay from SSR output switching to auxiliary output	5 cycles	5 cycles

12: Refer to Derating Curve for Auxiliary Output rating @ higher operating temperature

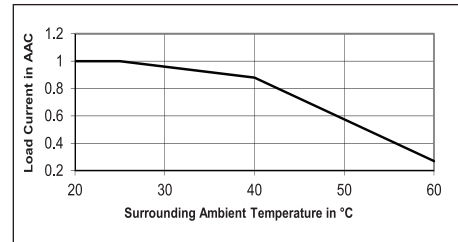

## Output Power Dissipation

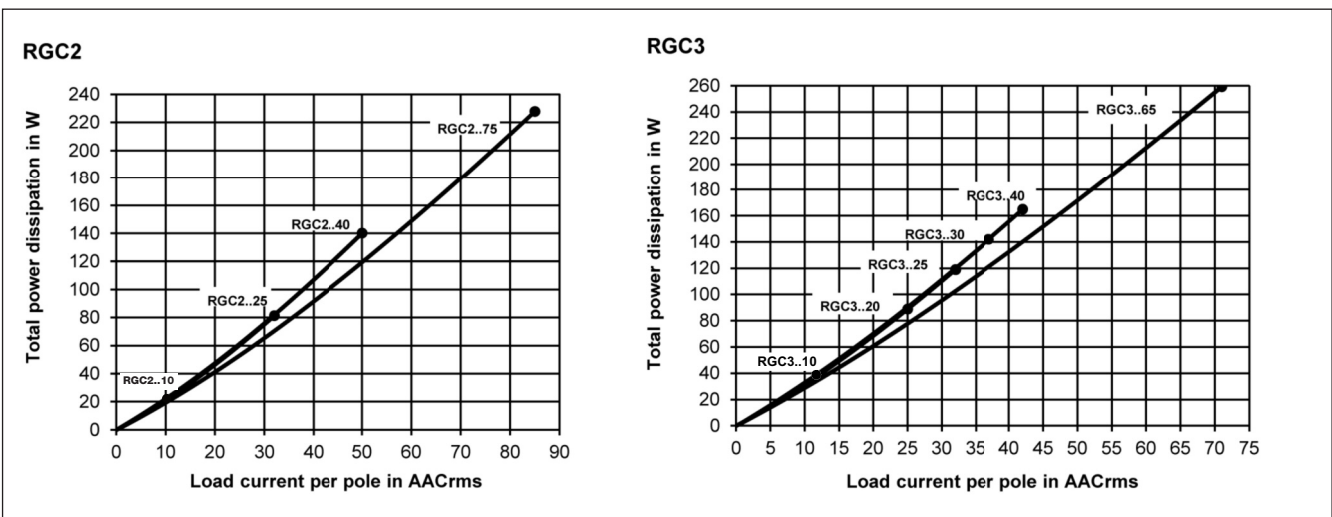



## Current Derating

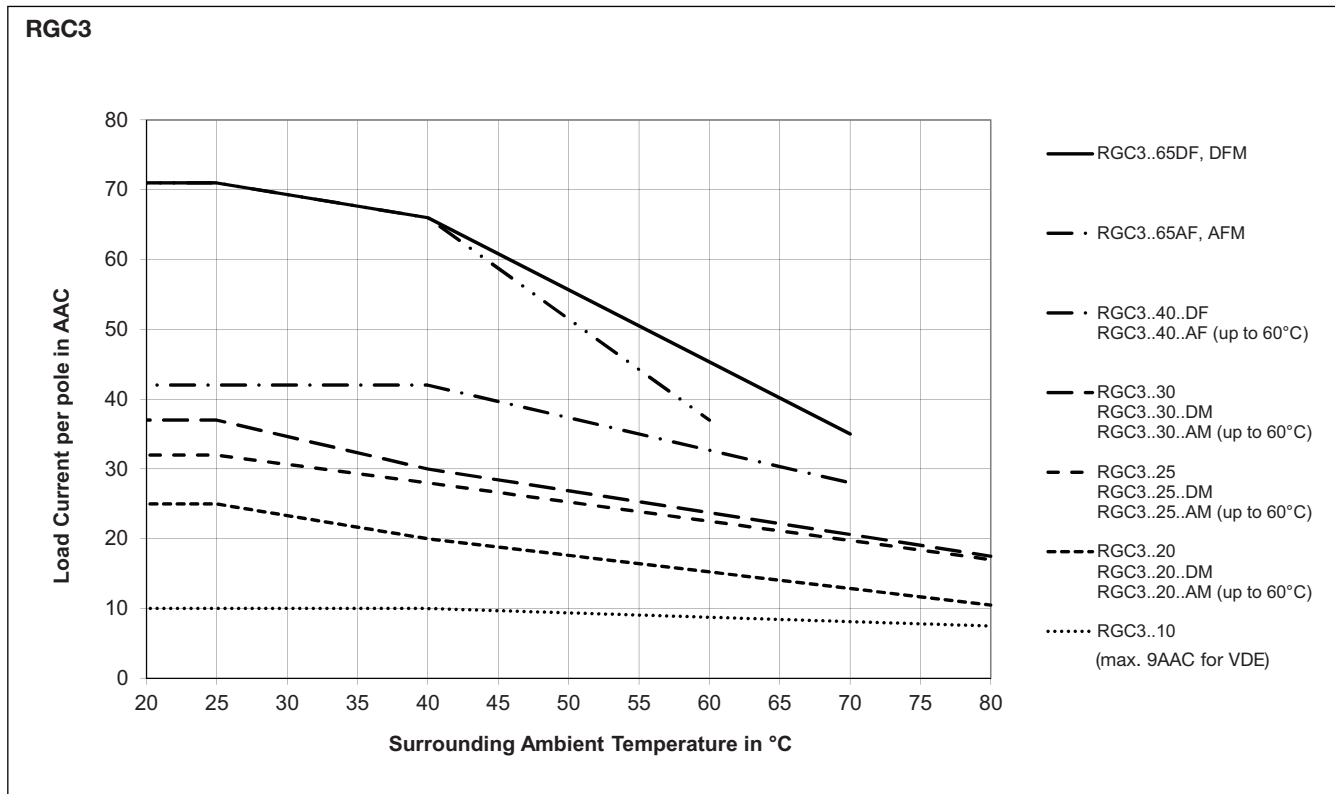
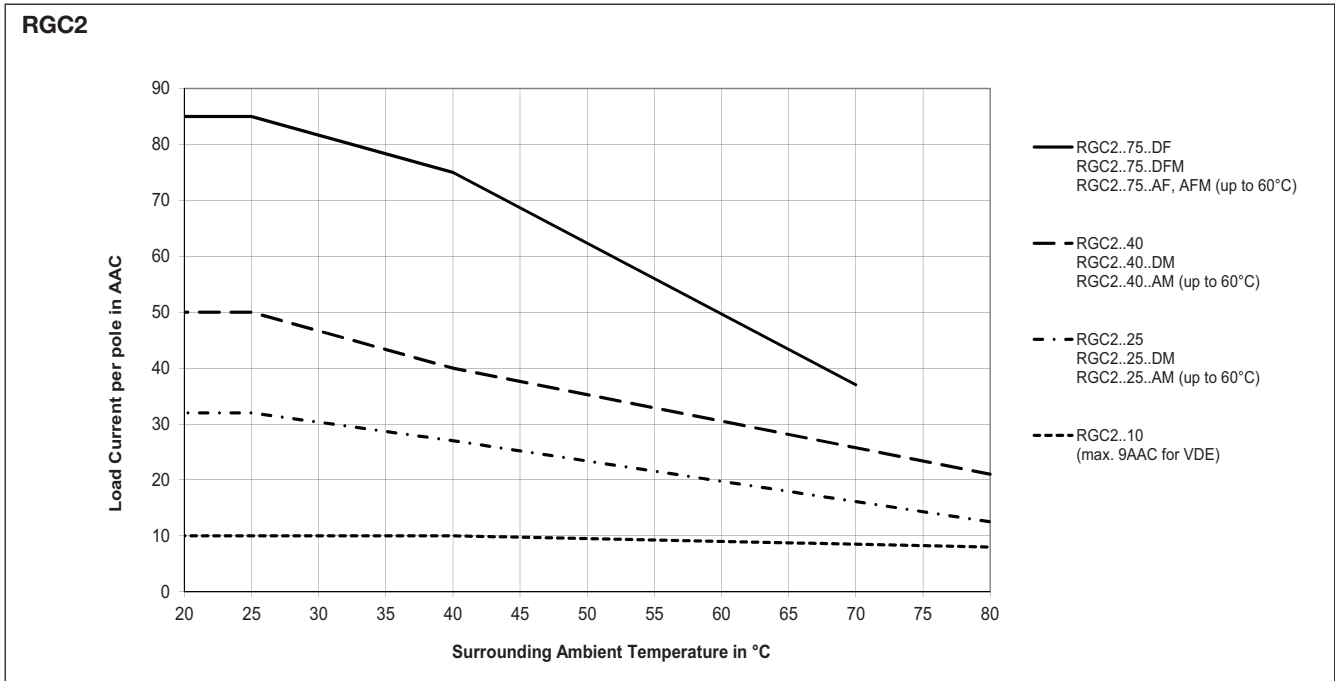

## Derating Vs. Spacing Curves

RGC2..10

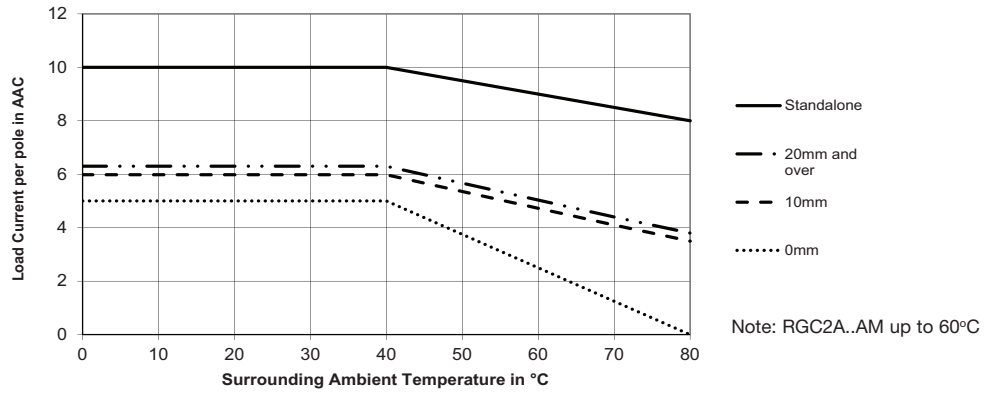

RGC2..25

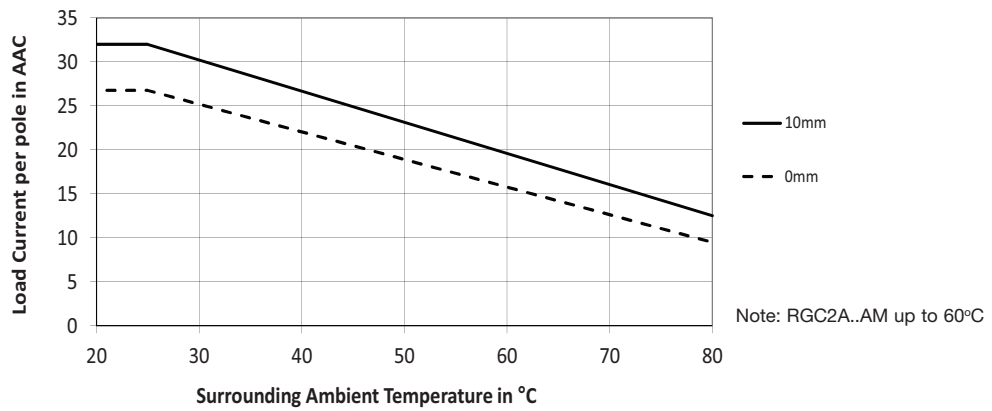

RGC2..40

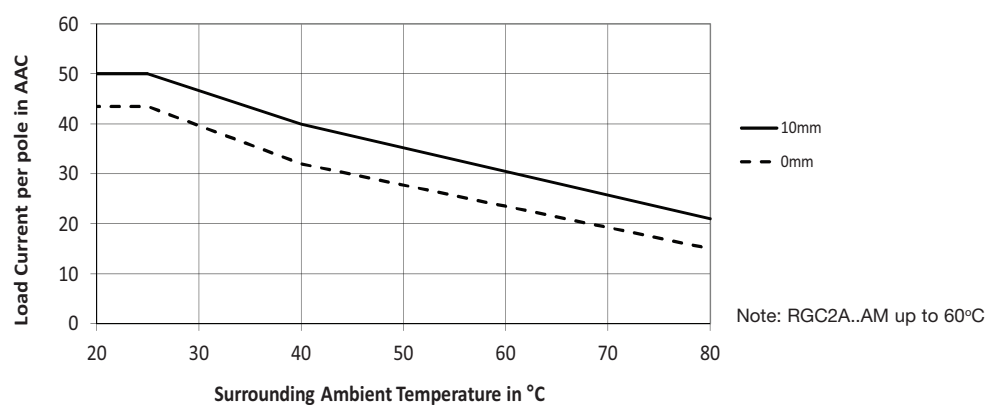

RGC2..75

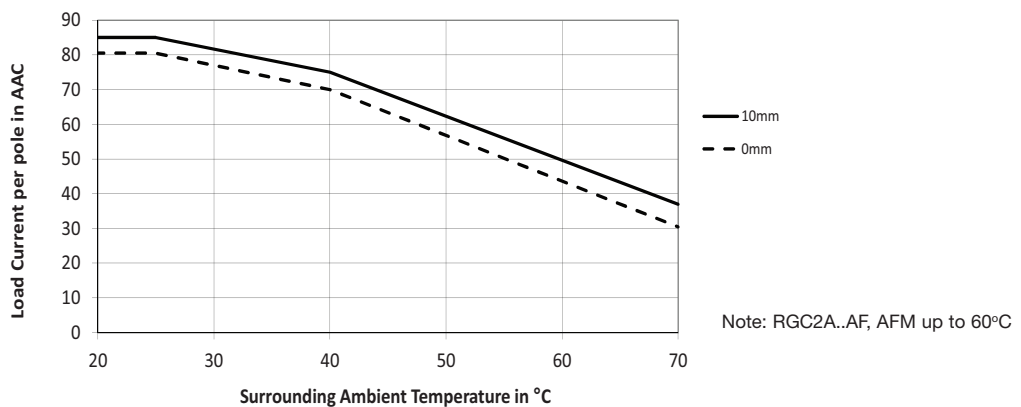



## Derating Vs. Spacing Curves - cont.

RGC3..10

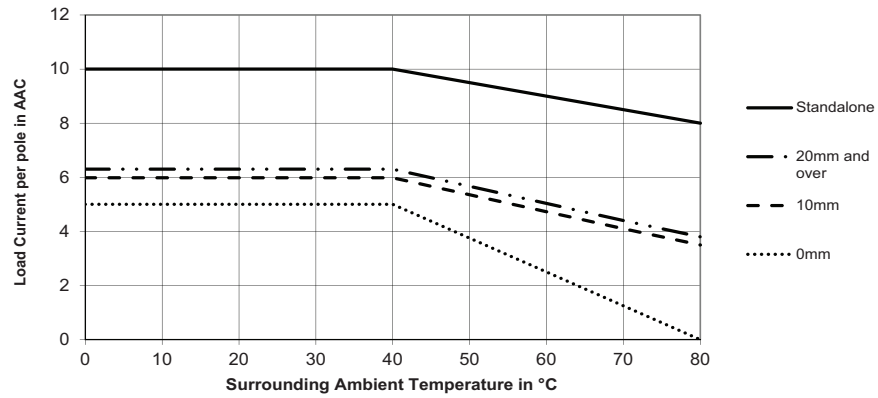

RGC3..20

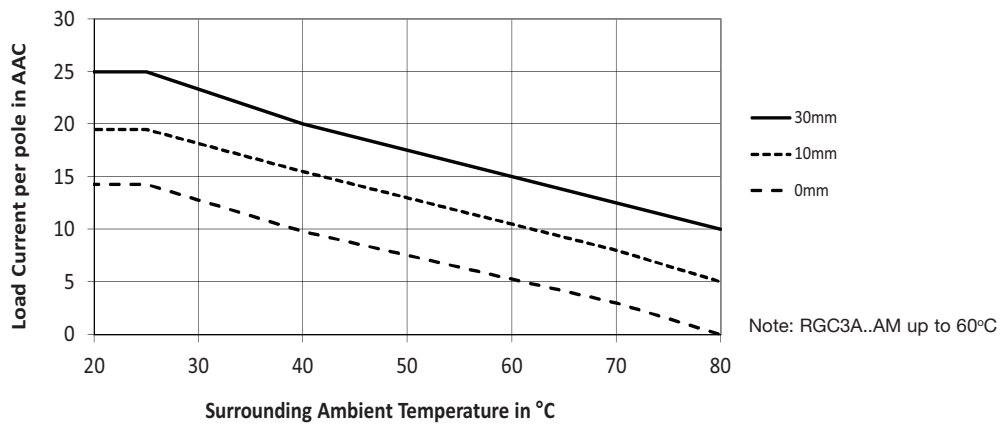

RGC3..25

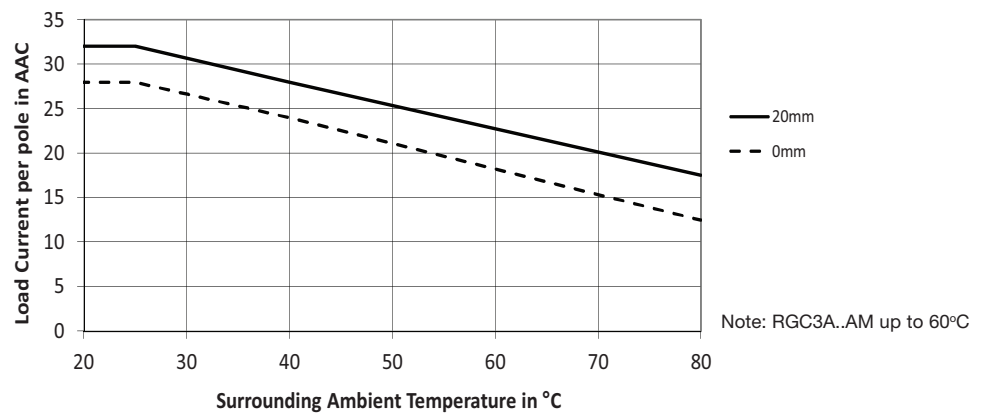

RGC3..30

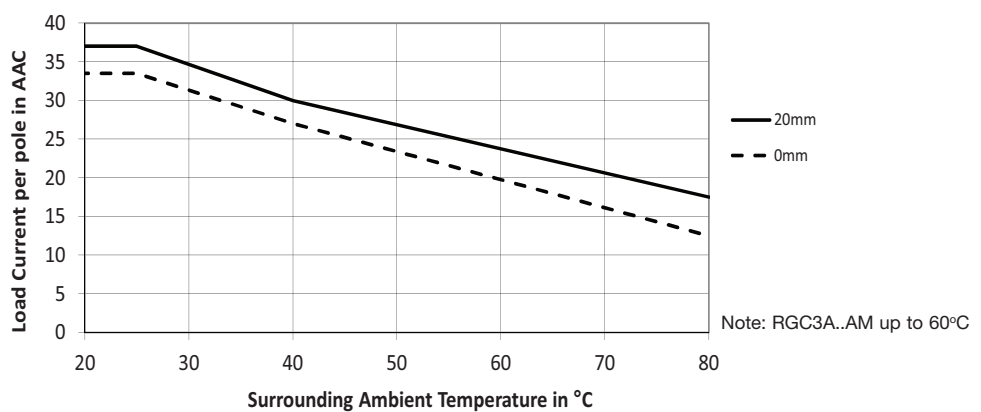



## Derating Vs. Spacing Curves - cont.

RGC3..40

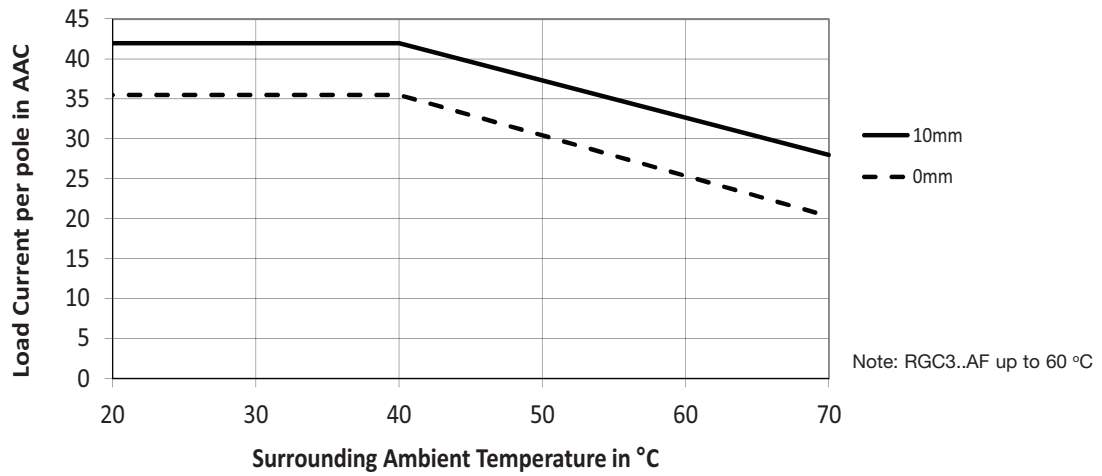

RGC3..65DF, DFM

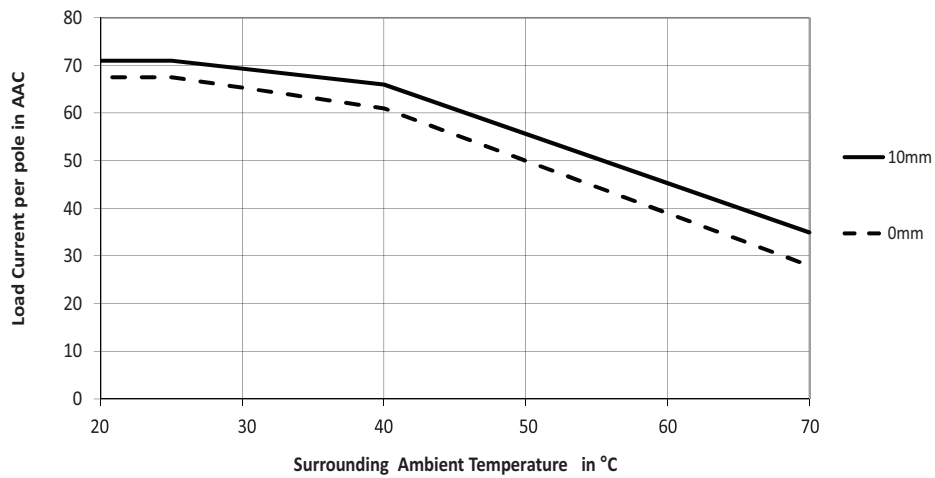

RGC3..65AF, AFM

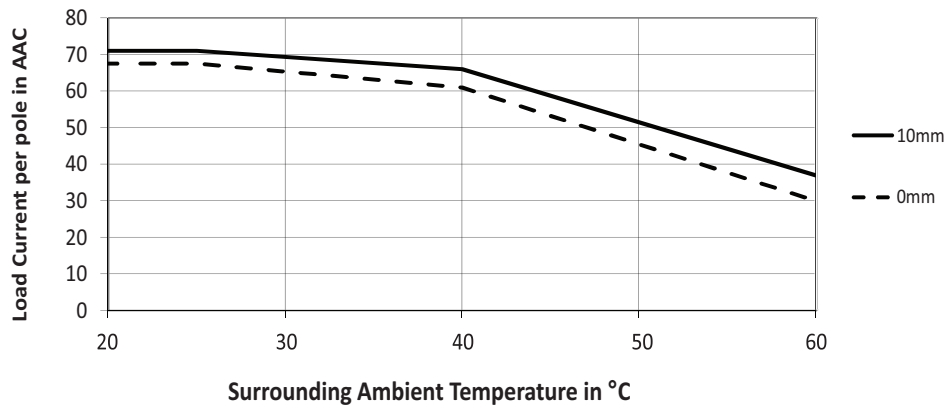

## Agency Approvals and Conformance

<b>Conformance</b>	EN/IEC 60947-4-2 EN/IEC 60947-4-3	<b>Agency Approvals</b>	UL Listed (E172877), UL508 cUL Listed (E172877), C22.2 No.14-13 CCC, GB/T 14048.5-2008 (IEC 60947-5-1)
<b>Short Circuit Current rating</b>	100kArms, UL508	RGC...10	VDE 0660-117, (DIN EN 60947-4-2) <sup>13</sup> VDE 0700-1 (DIN EN 60335-1) <sup>13</sup>



13: applicable only to RGC...10

## Electromagnetic Compatibility

<b>EMC immunity</b>	EN 60947-4-3	<b>Radiated radio frequency immunity</b>	EN/IEC 61000-4-3 Performance Criteria 1 Performance Criteria 1 Performance Criteria 1
<b>Electrostatic discharge (ESD) immunity</b> Air discharge, 8kV Contact, 4kV	EN/IEC 61000-4-2 Performance Criteria 2 Performance Criteria 2	<b>Conducted radio frequency immunity</b> 10V/m, 80 - 1000MHz 10V/m, 1.4 - 2.0GHz 10V/m, 2.0 - 2.7GHz	EN/IEC 61000-4-6 Performance Criteria 1
<b>Electrical fast transient (Burst) immunity</b> Output: 2kV, 5kHz Input: 1kV, 5kHz Signal: 1kV, 5kHz RGC..M	EN/IEC 61000-4-4 Performance Criteria 1 Performance Criteria 1 Performance Criteria 1	<b>Voltage dips immunity</b> 0% for 0.5/1cycle 40% for 10 cycles 70% for 25 cycles 80% for 250 cycles	EN/IEC 61000-4-11 Performance Criteria 2 Performance Criteria 2 Performance Criteria 2 Performance Criteria 2
<b>Electrical surge immunity</b> Output, line to line, 1kV Output, line to earth, 2kV Input, line to line, 1kV (A1, A2) Input, line to earth, 2kV (A1, A2) Signal, line to line, 500V (Us, 21, 22, 24) RGC..D..D Performance Criteria 1 Signal, line to line, 1kV (Us, 21, 22, 24) RGC..D..A Performance Criteria 1** RGC..A..A Performance Criteria 1** Signal, line to earth, 500V (Us, 21, 22, 24) RGC..D..D Performance Criteria 1 Signal, line to earth, 1kV (Us, 21, 22, 24) RGC..D..A Performance Criteria 1 RGC..A..A Performance Criteria 1 11, 12, 14, line to line, 1kV 11, 12, 14, line to earth, 2kV	EN/IEC 61000-4-5 Performance Criteria 1 Performance Criteria 1 Performance Criteria 2 Performance Criteria 2 Performance Criteria 1 Performance Criteria 1** Performance Criteria 1** Performance Criteria 1 Performance Criteria 1 Performance Criteria 1 Performance Criteria 1 Performance Criteria 1 Performance Criteria 1	<b>Voltage interruptions immunity</b> 0% for 5000ms	EN/IEC 61000-4-11 Performance Criteria 2
<b>EMC emission</b>	EN 60947-4-3*	<b>Radio interference field emission (radiated)</b> 30-1000MHz	EN/IEC 55011 Class A (Industrial)
<b>Radio interference voltage emission (conducted)</b> 0.15-30MHz	EN/IEC 55011 Class A (Industrial) with filters - see filter information		

### Note:

- Control input lines must be installed together to maintain products susceptibility to Radio Frequency Interference.
  - Use of AC solid state relays may according to the application and the load current, cause conducted radio interferences. Use of mains filters may be necessary for cases where the user must meet E.M.C requirements. The capacitor values given inside the filtering specification tables should be taken only as indications, the filter attenuation will depend on the final application.
  - This product has been designed for Class A equipment. Use of this product in domestic environments may cause radio interference, in which case the user may be required to employ additional mitigation methods.
  - Surge tests on RGC..A, RGC..A..A.. models were carried out with the signal line impedance network. In case the line impedance is less than 40Ω, it is suggested that AC supply is provided through a secondary circuit where the short circuit limit between conductors or between conductors and ground is 1500VA or less.
- \* For conformance to EN/IEC 61000-6-4, an external capacitor class X1, 220nF, 275VAC is to be connected across the input control lines A1-A2 for AC control versions.
- \*\* With external varistor 275V (S05K275) Type 2 connected between terminals 22 - 21 or terminals 24 - 21.

- Performance Criteria 1 (Performance Criteria A): No degradation of performance or loss of function is allowed when the product is operated as intended.
- Performance Criteria 2 (Performance Criteria B): During the test, degradation of performance or partial loss of function is allowed. However, when the test is complete the product should return operating as intended by itself.
- Performance Criteria 3 (Performance Criteria C): Temporary loss of function is allowed, provided the function can be restored by manual operation of the control.

## Filtering - EN/IEC 55011 Class A Compliance

Part Number	Suggested filter for compliance	Maximum heater current
RGC2A60..10	220nF / 760V / X1	10 AAC
RGC2A22..25	220nF / 275V / X1	25 AAC
RGC2A60..25	220nF / 760V / X1	25 AAC
RGC2A60..40	330nF / 760V / X1	40 AAC
RGC2A60..75	470nF / 760V / X1	65 AAC
RGC3A22..10	220nF / 275V / X1	10 AAC
RGC3A60..10	220nF / 760V / X1	10 AAC
RGC3A22..20	220nF / 275V / X1	25 AAC
RGC3A60..20	220nF / 760V / X1	25 AAC
RGC3A60..25	330nF / 760V / X1	25 AAC
RGC3A60..30	470nF / 760V / X1	30 AAC
RGC3A60..40	470nF / 760V / X1	40 AAC
RGC3A60..65	470nF / 760V / X1	65 AAC

## Filter Connection Diagrams

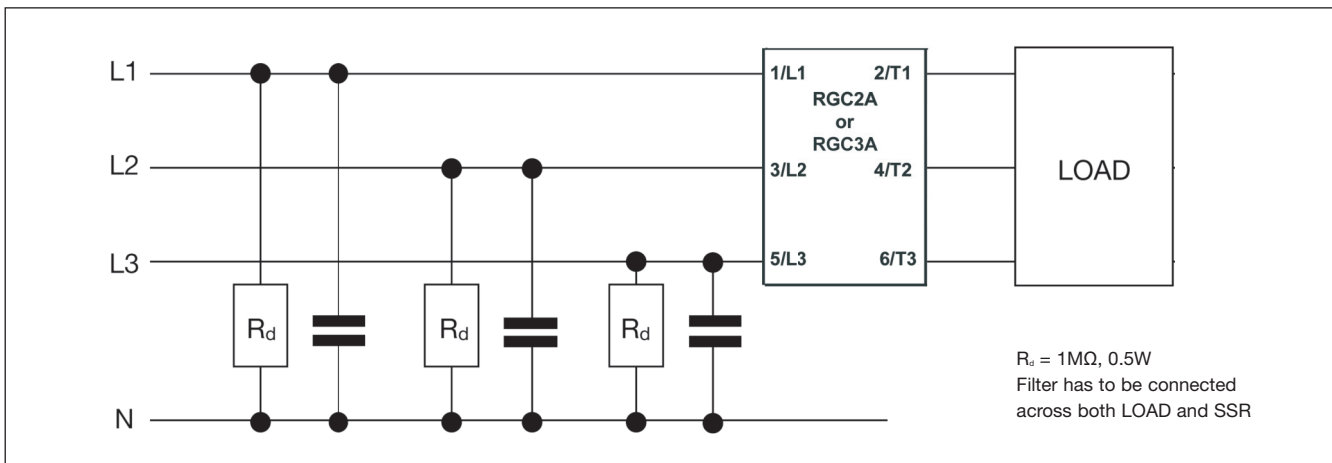

## Environmental Specifications

<b>Operating temperature</b>	-40°C to +80°C (-40°F to +176°F) RGC...DF, DFM -40°C to +70°C (-40°F to +158°F) RGC...AM, AF, AFM -40°C to +60°C (-40°F to +140°F)	<b>UL flammability rating</b> (for plastic)	UL 94 V0 Glow wire ignition temperature, Glow wire flammability index Conform to EN 60335-1 requirements
<b>Storage temperature</b>	-40°C to +100°C (-40°F to +212°F)	<b>Installation altitude</b>	0 - 1000m. Above 1000m derate linearly by 1% of FLC per 100m up to maximum of 2000m
<b>Impact resistance</b> (EN50155, EN61373)	15/11 g/ms	<b>Weight</b>	
<b>Vibration resistance</b> (2-100Hz, IEC60068-2-6, EN50155, EN61373)	2g per axis	RGC....10	approx. 470g
<b>Relative humidity</b>	95% non condensing @ 40°C	RGC2..25, RGC3..20 (M)	approx. 600g (680g)
<b>EU RoHS compliant</b>	Yes	RGC2..40, RGC3..25, RGC3..30 (M)	approx. 850g (920g)
<b>China RoHS compliant</b>	Refer to Environmental Information (Page 32)	RGC3..40	approx. 740g
		RGC2..75, RGC3..65	approx. 980g

# Terminal Layout

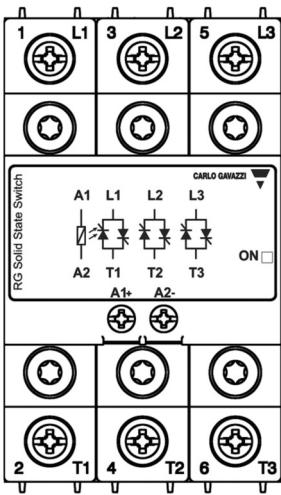

RGC2..10, RGC2..25, RGC2..40  
RGC3..10, RGC3..20, RGC3..25, RGC3..30

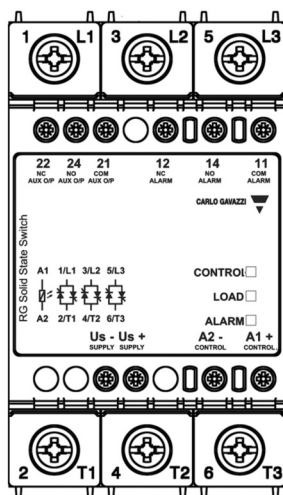

RGC2..25..DM, RGC2..40..DM  
RGC3..20..DM, RGC3..25..DM, RGC3..30..DM

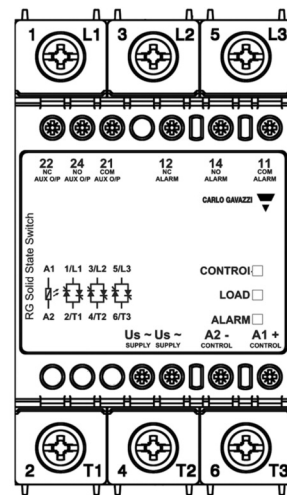

RGC2..25..AM, RGC2..40..AM  
RGC3..20..AM, RGC3..25..AM, RGC3..30..AM

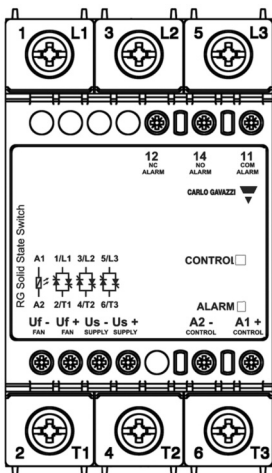

RGC2..75..DF  
RGC3..40..DF, RGC3..65..DF

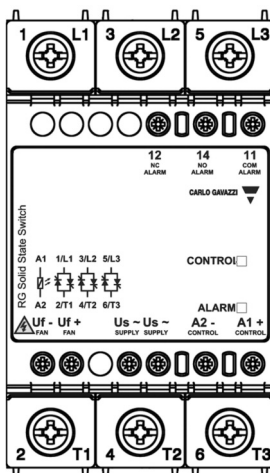

RGC2..75..AF  
RGC3..40..AF, RGC3..65..AF

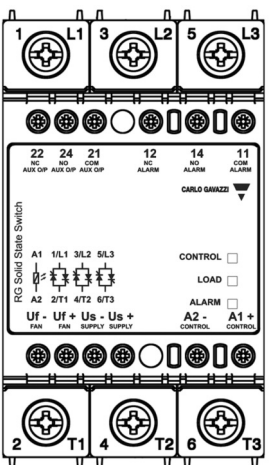

RGC2..75..DFM  
RGC3..65..DFM

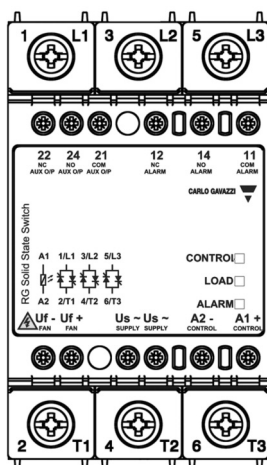

RGC2..75..AFM  
RGC3..65..AFM

### Terminals labelling:

- 1/L1, 2/L2, 3/L3: Mains connections
- 2/T1, 4/T2, 6/T3: Load connections
- A1(+): Positive control signal
- A2(-): Control ground
- Us(+): External supply positive signal
- Us(-): External supply ground
- Us~): AC external supply
- Uf(+): Fan supply positive signal  
(no connection required by end user)
- Uf(-): Fan supply ground  
(no connection required by end user)
- 12: Alarm EMR, normally closed
- 14: Alarm EMR, normally open
- 11: Alarm EMR, common terminal
- 22: Auxiliary output, normally closed
- 24: Auxiliary output, normally open
- 21: Auxiliary output, common terminal



Connections to Uf+, Uf- are provided readily terminated by manufacturer. However, in case of needed user intervention on terminals Uf+, Uf- for the RGC..A..AF and RGC..A..AFM models, the mains supply has to be turned off first to avoid risk of electrical shock.

## Dimensions

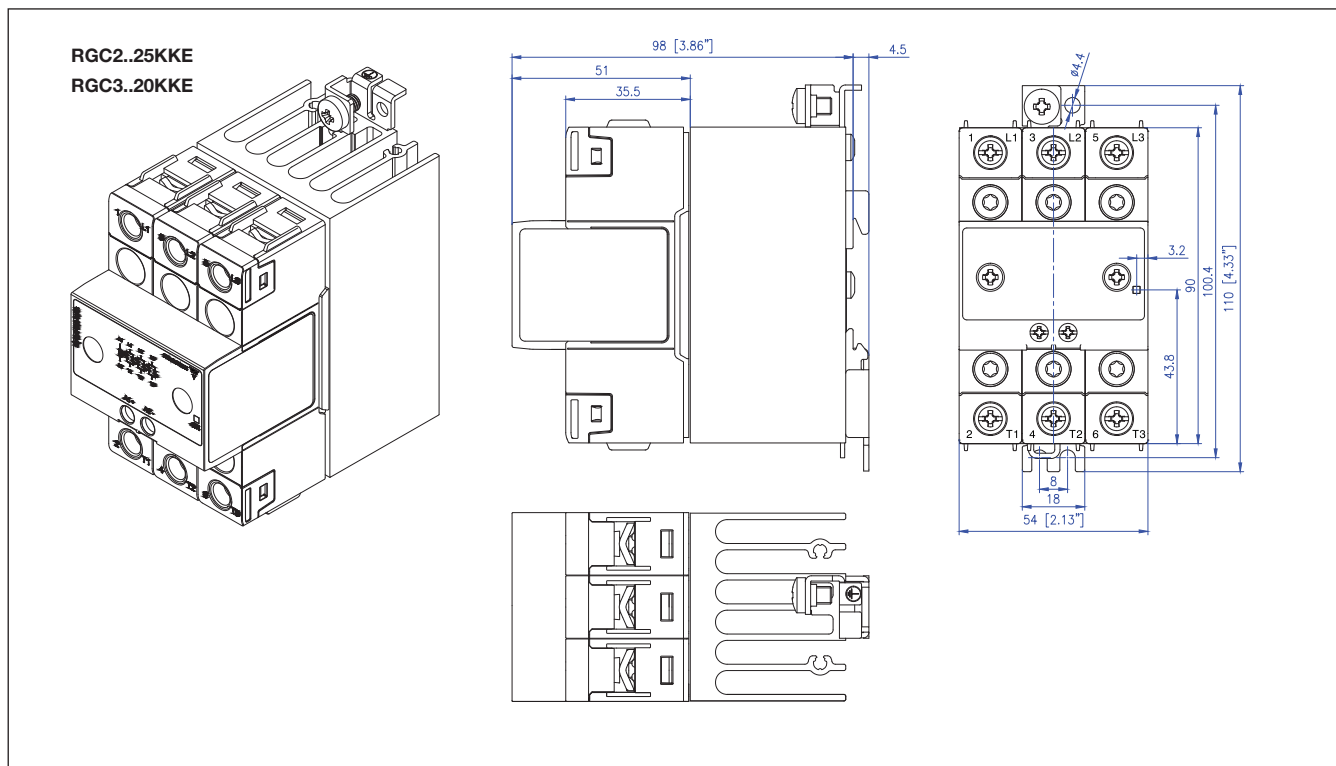
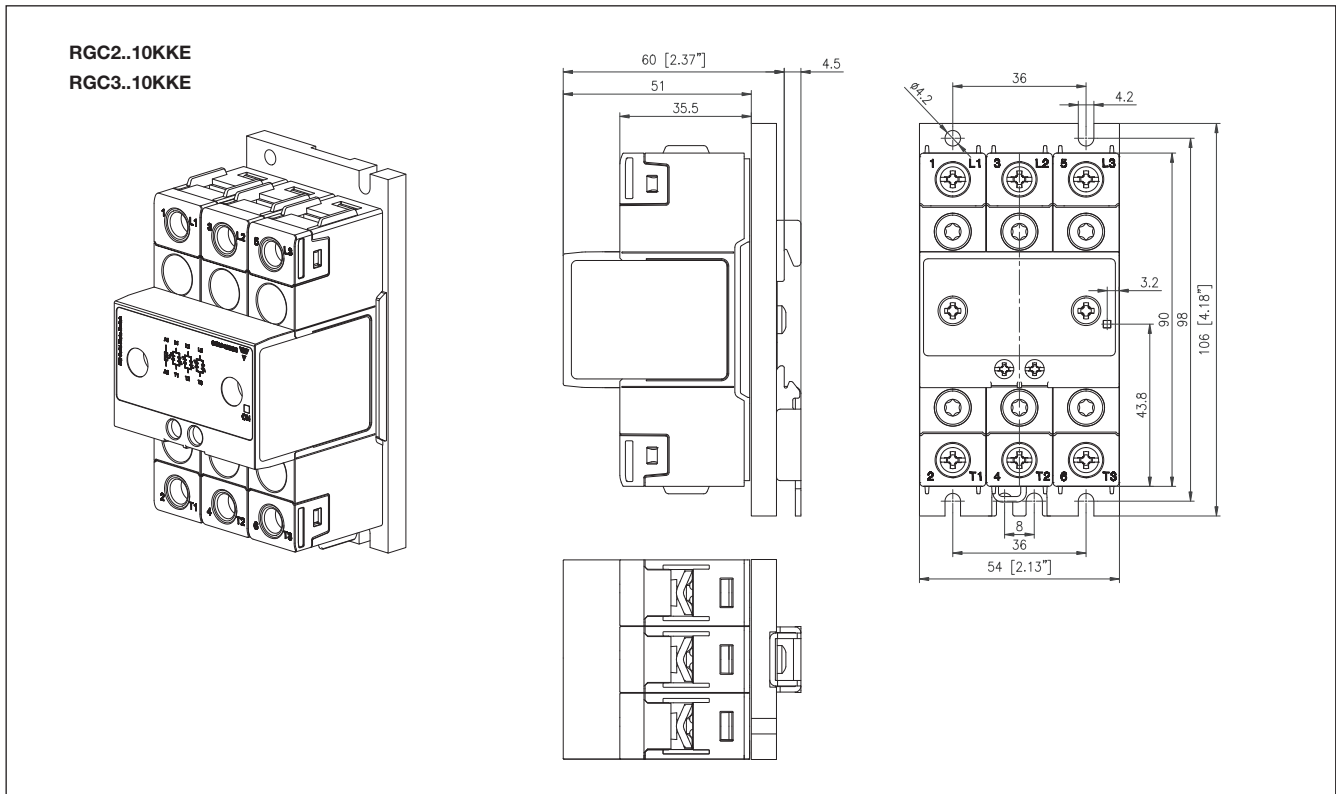

Dimensions in mm. Housing width tolerance +0.5mm, -0mm as per DIN43880.  
All other tolerances ±0.5mm

## Dimensions

RGC2..25GKE..M  
RGC3..20GKE..M

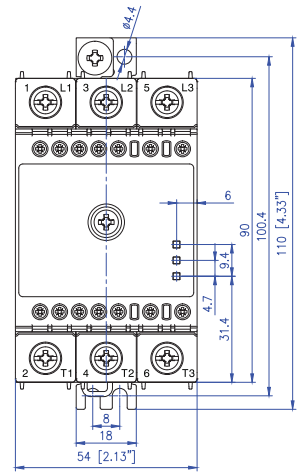
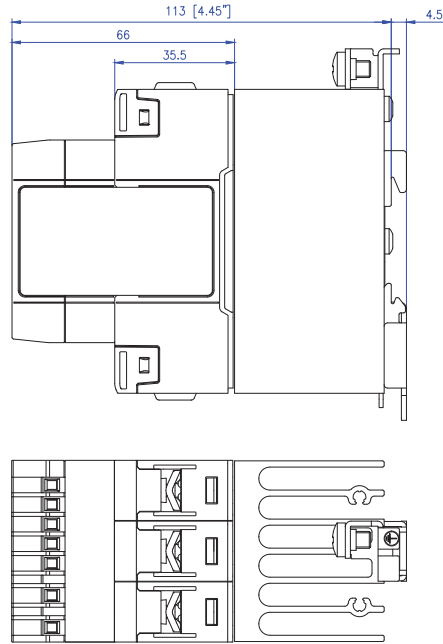
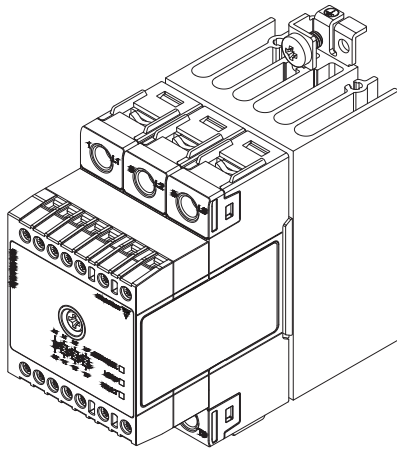

RGC3..25KKE

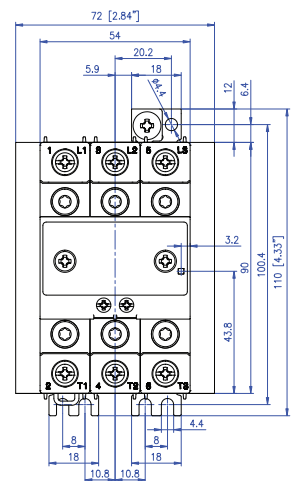
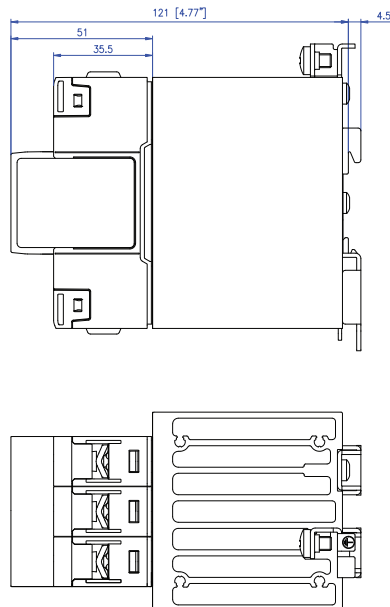
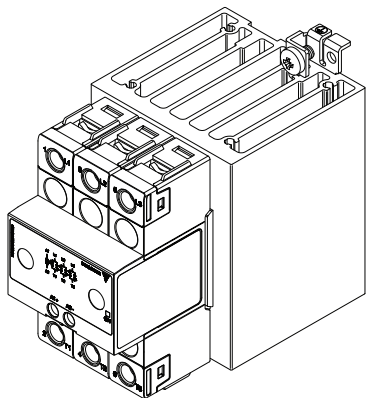

Dimensions in mm. Housing width tolerance +0.5mm, -0mm as per DIN43880.  
All other tolerances ±0.5mm

## Dimensions

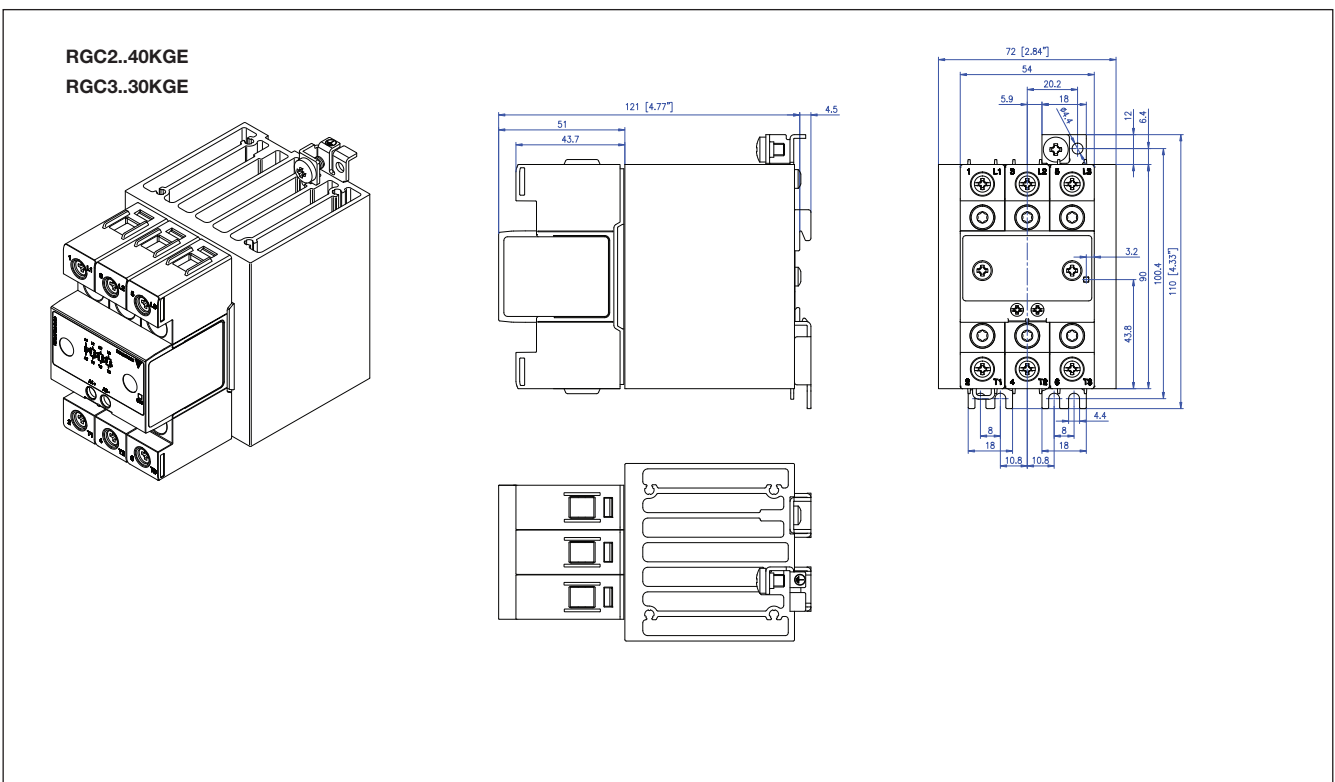
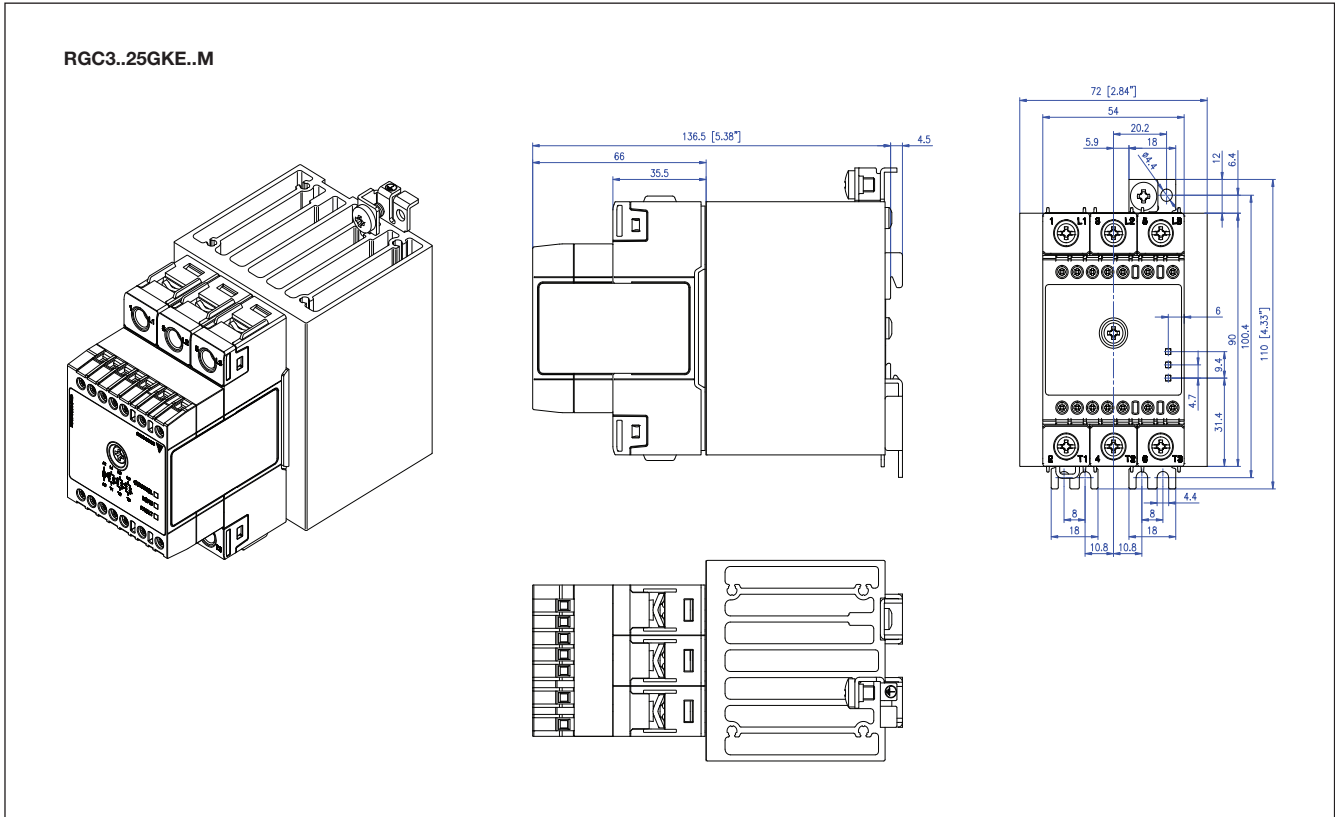

Dimensions in mm. Housing width tolerance +0.5mm, -0mm as per DIN43880.  
All other tolerances ±0.5mm







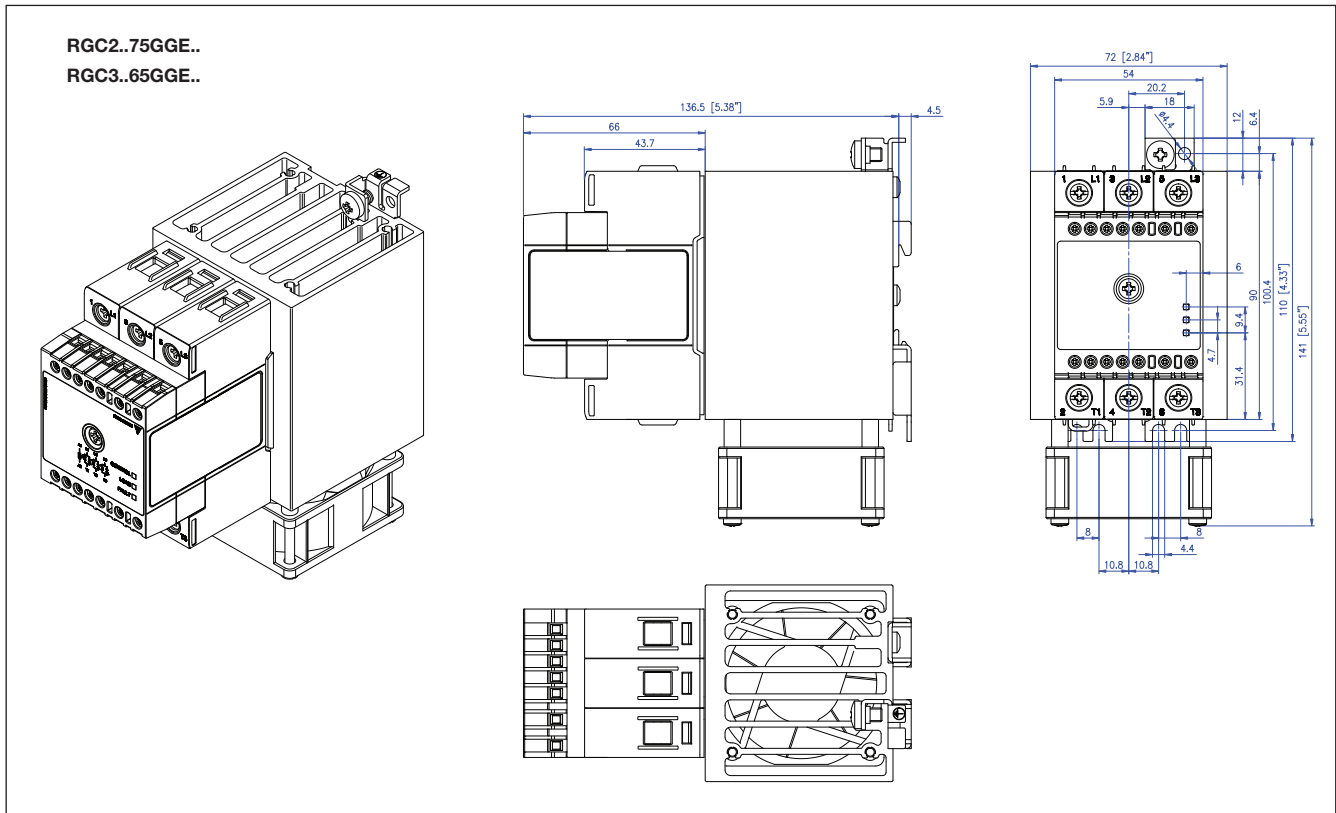







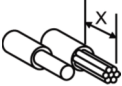

## Dimensions

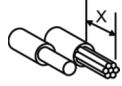

Dimensions in mm. Housing width tolerance +0.5mm, -0mm as per DIN43880.  
All other tolerances  $\pm 0.5\text{mm}$

## Connection Specifications

<b>POWER CONNECTIONS</b>		<b>1/L1, 3/L2, 5/L3, 2/T1, 4/T2, 6/T3</b>		
Use 75°C copper (Cu) conductors		<b>RG..KKE, RG..GKE</b>		<b>RG..KGE, RG..GGE</b>
				
Stripping length (X)		12mm		11mm
Connection type		M4 screw with captivated washer		M5 screw with box clamp
Rigid (solid & stranded) UL/cUL rated data		2x 2.5 - 6.0 mm <sup>2</sup> 2x 14 - 10 AWG	1x 2.5 - 6.0 mm <sup>2</sup> 1x 14 - 10 AWG	1x 2.5 - 25 mm <sup>2</sup> 1x 14 - 3 AWG
Flexible with end sleeve		2x 1.0 - 2.5 mm <sup>2</sup> 2x 2.5 - 4.0 mm <sup>2</sup> 2x 18 - 14 AWG 2x 14 - 12 AWG	1x 1.0 - 4.0 mm <sup>2</sup> 1x 18 - 12 AWG	1x 2.5 - 16 mm <sup>2</sup> 1x 14 - 6 AWG
Flexible without end sleeve		2x 1.0 - 2.5 mm <sup>2</sup> 2x 2.5 - 6.0 mm <sup>2</sup> 2x 18 - 14 AWG 2x 14 - 10 AWG	1x 1.0 - 6.0 mm <sup>2</sup> 1x 18 - 10 AWG	1x 4.0 - 25 mm <sup>2</sup> 1x 12 - 3 AWG
Torque specification		Pozidriv 2 UL: 2Nm (17.7 lb-in) IEC: 1.5-2.0Nm (13.3-17.7 lb-in)		Pozidriv 2 UL: 2.5Nm (22 lb-in) IEC: 2.5-3.0Nm (22-26.6 lb-in)
Aperture for termination lug		12.3mm		n/a
Protective Earth (PE) connection		M5, 1.5Nm (13.3 lb-in) Not provided with SSR. PE connection required when product is intended to be used in Class 1 applications according to EN/IEC 61140		
<b>CONTROL CONNECTIONS</b>		<b>A1, A2</b>		<b>A1, A2, Us, Uf, 11, 12, 14, 21, 22, 24</b>
Use 75°C copper (Cu) conductors		<b>RG..KKE, RG..GKE</b>		<b>RG..GKE, RG..GGE</b>
				
Stripping length (X)		8mm		8 mm
Connection type		M3 screw with captivated washer		M3 screw with box clamp
Rigid (solid & stranded) UL/cUL rated data		2x 0.5 - 2.5 mm <sup>2</sup> 2x 18 - 12 AWG	1x 0.5 - 2.5 mm <sup>2</sup> 1x 18 - 12 AWG	1x 1.0 - 2.5 mm <sup>2</sup> 1x 18 - 12 AWG
Flexible with end sleeve		2x 0.5 - 2.5 mm <sup>2</sup> 2x 18 - 12 AWG	1x 0.5 - 2.5 mm <sup>2</sup> 1x 18 - 12 AWG	1x 0.5 - 2.5 mm <sup>2</sup> 1x 20 - 12 AWG
Torque specification		Pozidriv 1 UL: 0.5Nm (4.4 lb-in) IEC: 0.5-0.6Nm (4.4-5.3 lb-in)		Pozidriv 1 UL: 0.5Nm (4.4 lb-in) IEC: 0.4-0.5Nm (3.5-4.4 lb-in)

## Connection Diagram

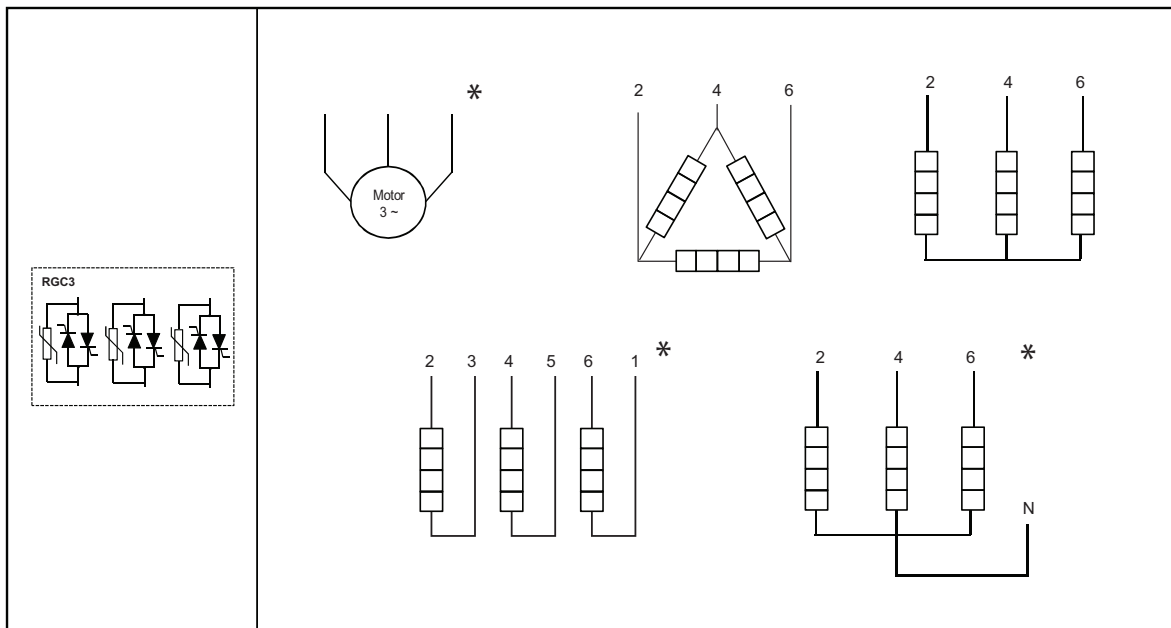
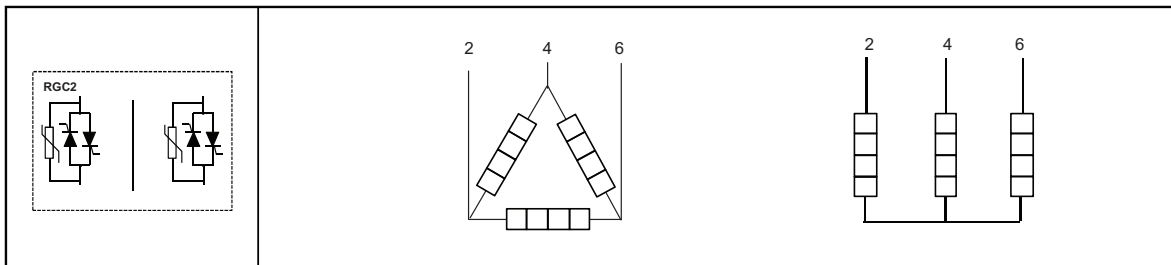
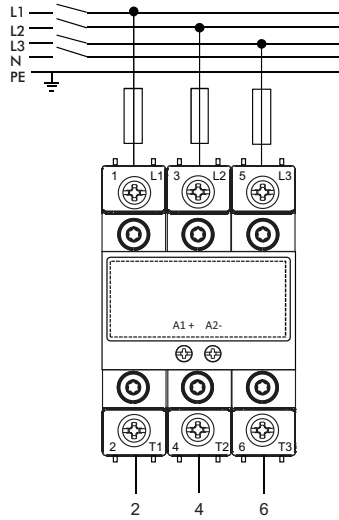

\* Not suitable for use with RGC...M versions

## Connection Configuration for Auxiliary Output

Versions: RGC..D..DM, RGC..D..DFM

Auxiliary output signal 24VDC, 50mA; DC control, U<sub>c</sub> (5-32VDC); DC external supply, U<sub>s</sub> (24VDC)

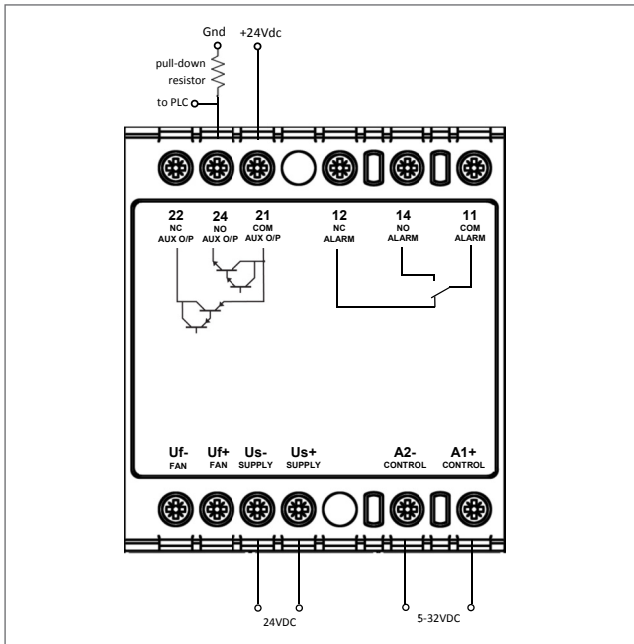

Connection of normally open auxiliary output (24-21) in a 'pnp' style

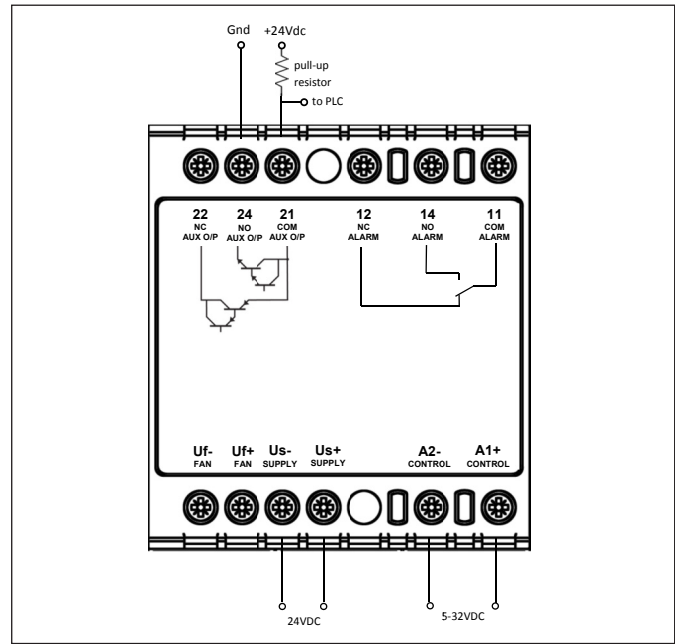

Connection of normally open auxiliary output (24-21) in an 'npn' style

Versions: RGC..D..AM, RGC..D..AFM

Auxiliary output signal 24VDC, 50mA; DC control, U<sub>c</sub> (5-32VDC); AC external supply, U<sub>s</sub> (90-250VAC)

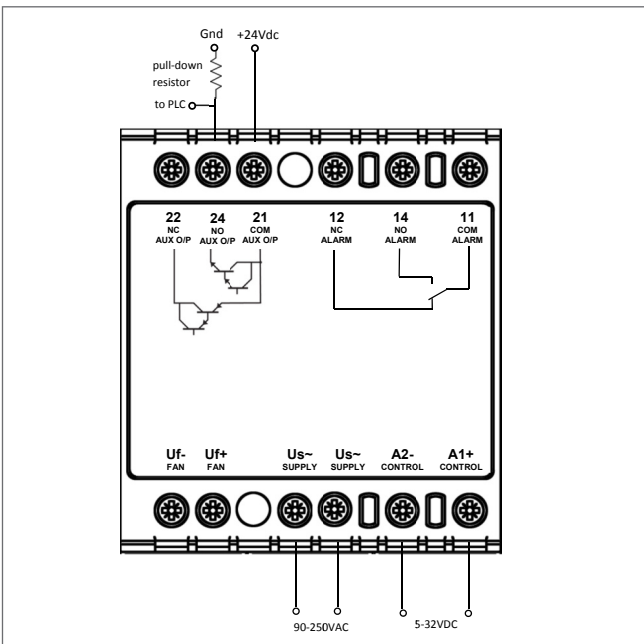

Connection of normally open auxiliary output (24-21) in a 'pnp' style

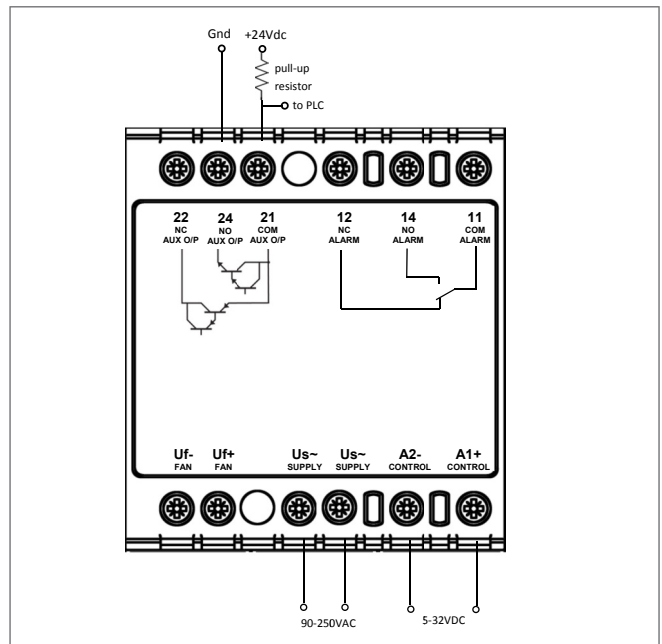

Connection of normally open auxiliary output (24-21) in an 'npn' style

## Conection Configuration for Auxiliary Output

Versions: RGC..A..AM, RGC..A..AFM

Auxiliary output signal 90-250VAC, max. 1A @ 25°C; AC control, U<sub>c</sub> (20-275VAC); AC external supply, U<sub>s</sub> (90-250VAC)

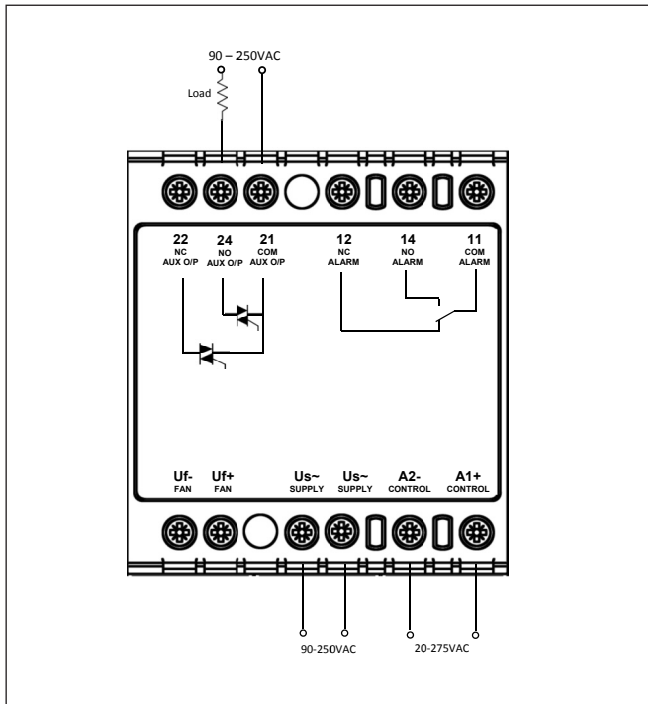

Connection of normally open auxiliary output (24-21) to an AC load

Note: In relation to the auxiliary output terminals 22, 24, 21; it is not possible to connect all 3 terminals to the auxiliary circuit. Preference shall be given to either a normally open (24-21) or normally closed (22-21) contact. The respective terminations shall be chosen and configured accordingly.

## RGC..M Mode of Operation

The RGC..M versions are suitable only for use with resistive loads.

The 'M' suffix versions integrate monitoring circuitry that can detect the status of the Mains, Load, and Solid State Relay (SSR) status. The fault conditions that can be detected with the RGC..M include:

- Mains loss
- Load loss
- SSR open circuit
- SSR short circuit
- SSR over temperature

An external supply, 24VDC or 90-250VAC, selectable through part no. configuration, is required for the operation of the RGC..M models. In the case of a fault condition, an EMR alarm output is available through terminals 11, 12, 14 for remote indication. Alarm visual indication is provided by a flashing red LED. The flash rate of the red LED gives an indication of the type of alarm condition detected.

The RGC..M is also equipped with an auxiliary output which operates in synchronisation with the output of the SSR. This electronic auxiliary output with normally open or normally closed user selectable contacts is available through terminals 21, 22, 24. A yellow LED gives indication of the SSR output status.

### Mains Loss:

The mains loss alarm is issued if the mains voltage is missing from either terminals L1, L2 or L3 for more than 1 second. This alarm type is indicated by 2 flashes of the red LED. The alarm resets automatically once the mains voltage is restored and is present on terminals L1, L2 and/or L3 for more than 1 second.

	Supply Voltage (Us) Loss	Supply Voltage (Us) Loss	Normal Operation SSR OFF	Normal Operation SSR ON	Mains Loss Detection (> 1s)	Normal Operation SSR ON
Mains Supply (L1, L2, L3)	█	█	█	█		█
Load Supply (T1, T2, T3)				█		█
Load Current				█		█
Auxiliary Output, NO (21-24)	█	█	█	█		█
Auxiliary Output, NC (21-22)			█		█	
Supply Voltage (Us)			█	█		█
Control Voltage (A1, A2)		█		█	█	█
Green LED (Control & Supply)			█	█	█	█
Yellow LED (Load status)				█		█
Red LED (Alarm LED)					█ █ █ █ █ █	
Alarm Output, NO (11-14)					█	
Alarm Output, NC (11-12)	█	█	█	█		█









## RGC..M Mode of Operation (continued)

### SSR Open Circuit:

This alarm is issued when either one of the poles or all 3 poles do not switch ON within 250ms when control voltage is applied. This alarm type is identified by 4 flashes of the red LED.

#### Example Condition 1:

Once the open circuit alarm is issued it remains present for 1 minute as long as control voltage is ON. After 1 minute, an attempt to switch ON the SSR is made if control is ON. In case the open circuit condition is still present the alarm is issued again. In the case of an open circuit on only 1 pole the load will switch on 2 phases for 250ms until the open circuit condition on the damaged pole is detected. As soon as the open circuit condition is detected, an alarm is issued and the SSR output is switched OFF. This cycle will repeat for a count of 10 times as long as the control voltage is present. After 10 times no further switch re-attempts are made. It is necessary to reset the external supply (Us) to re-attempt a switch ON. In case failure persists device is to be returned to factory.

#### Example Condition 2:

Once the open circuit alarm is issued it remains present for 1 minute as long as control voltage is ON. If during this period the control voltage is switched OFF, the alarm is automatically cleared and the count indicated in Condition 1 is also set to 0. If control voltage is re-applied and the open circuit condition is detected an alarm is issued accordingly. After 1 minute, an attempt to switch ON the SSR is made if control is still ON. This will continue for a count of 10 times as long as the control voltage is present. After 10 times no further switch re-attempts are made. It is necessary to reset the external supply (Us) to re-attempt a switch ON. In case failure persists device is to be returned to factory.

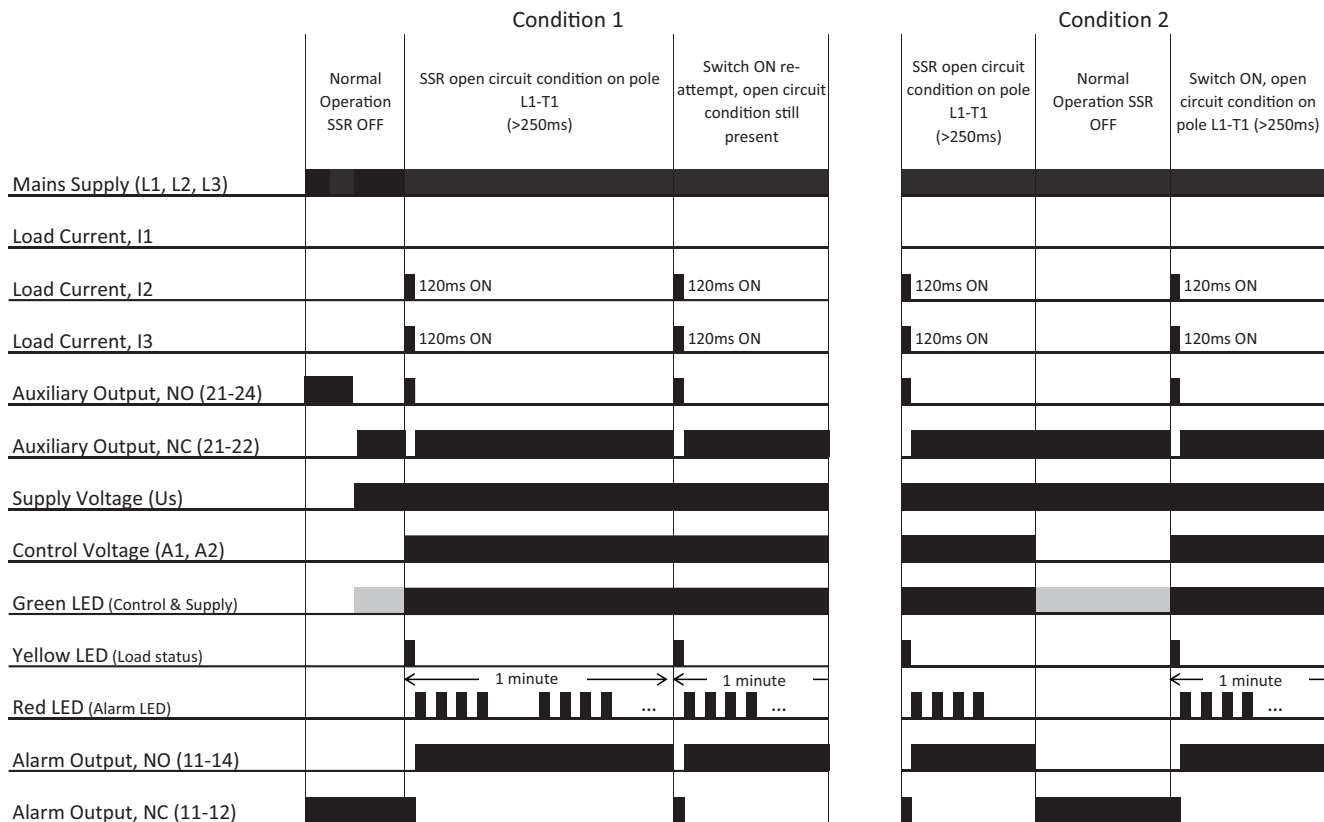



## RGC..M Mode of Operation (continued)

### SSR Over Temperature:



The SSR is equipped with internal temperature monitoring to prevent SSR damage in case of overheating conditions. Upon detection of such a condition the SSR output is switched OFF and an alarm is issued accordingly. This alarm is visually indicated by the red LED which is fully ON. Once the temperature cools down, the alarm is cleared and if control is still ON an attempt to re-start the SSR is made.

	Normal Operation SSR OFF	Normal Operation SSR ON	Over Temperature	Over Temperature condition cleared
Mains Supply (L1, L2, L3)	■	■	■	■
Load Supply (T1, T2, T3)		■		■
Load Current		■		■
Auxiliary Output, NO (21-24)	■	■		■
Auxiliary Output, NC (21-22)	■		■	
Supply Voltage (Us)	■	■	■	■
Control Voltage (A1, A2)		■	■	■
Green LED (Control & Supply)	■	■	■	■
Yellow LED (Load status)		■		■
Red LED (Alarm LED)			■	
Alarm Output, NO (11-14)			■	
Alarm Output, NC (11-12)	■			■

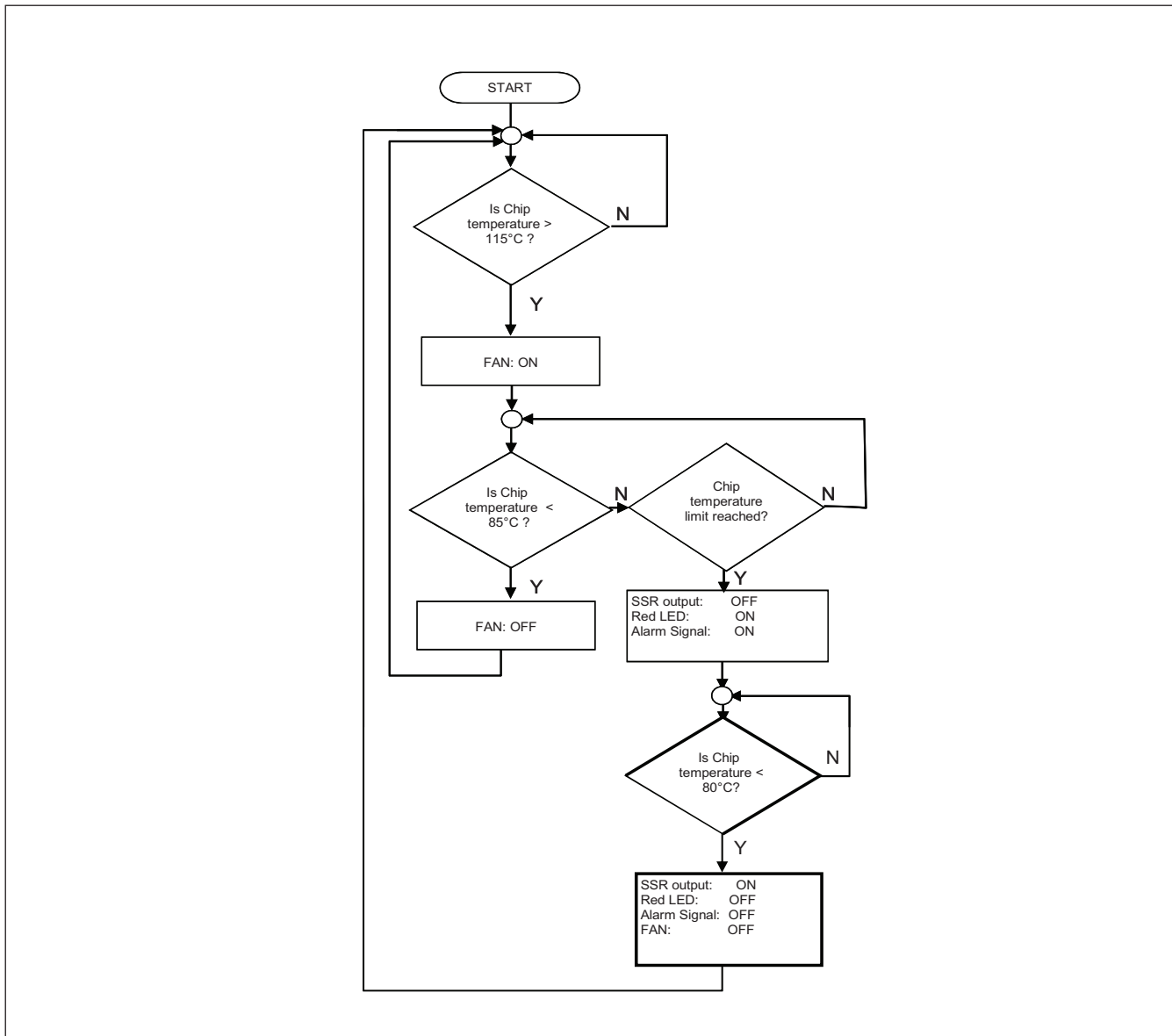
## Fan operation for versions with integrated fan

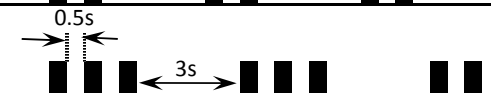

## Red LED Alarm Indications

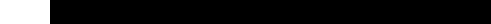
Flashes	Description of Fault	Timing Diagram
2	Mains loss	
3	Load loss or SSR short circuit	
4	SSR open circuit	
100%	SSR over temperature	

## Installation Instructions

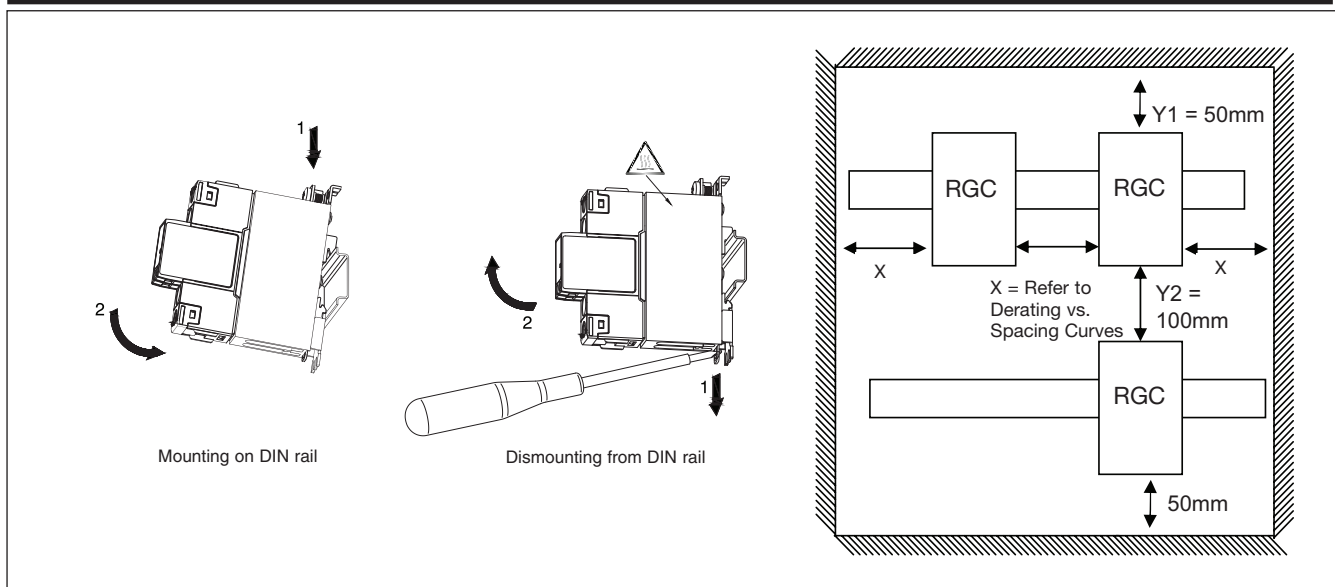

## Short Circuit Protection

### Protection Co-ordination, Type 1 vs Type 2:

Type one protection implies that after a short circuit, the device under test will no longer be in a functioning state. In type 2 co-ordination the device under test will still be functional after the short circuit. In both cases, however the short circuit has to be interrupted. The fuse between enclosure and supply shall not open. The door or cover of the enclosure shall not be blown open. There shall be no damage to conductors or terminals and the conductors shall not separate from terminals. There shall be no breakage or cracking of insulating bases to the extent that the integrity of the mounting of live parts is impaired. Discharge of parts or any risk of fire shall not occur.

The product variants listed in the table hereunder are suitable for use on a circuit capable of delivering not more than 100,000A ms Symmetrical Amperes. 600Volts maximum when protected by fuses. Tests at 100,000A were performed with Class J fuses, fast acting; please refer to the tables below for maximum. Tests with Class J fuses are representative of Class CC fuses.

### Co-ordination type 1 (UL508)

Part No.	Max. fuse size [A]	Class	Short circuit current [kArms]	Voltage [VAC]
RGC2..10	30	J or CC	100	Max. 600
RGC2..25	30	J or CC	100	Max. 600
RGC2..40	40	J	100	Max. 600
RGC2..75	60 <sup>14</sup>	J	100	Max. 600
RGC3..10	30	J or CC	100	Max. 600
RGC3..20	30	J or CC	100	Max. 600
RGC3..25	30	J or CC	100	Max. 600
RGC3..30	40	J	100	Max. 600
RGC3..40	40	J	100	Max. 600
RGC3..65	60 <sup>14</sup>	J	100	Max. 600

14: Consult a Carlo Gavazzi sales representative for use of 70A class J fuses

**Co-ordination type 2 (EN/IEC 60947-4-2/4-3)**

Suitable for motor load applications

Part No.	Ferraz Shawmut (Mersen)		Siba		Short circuit current [kArms]	Voltage [VAC]
	Max. fuse size [A]	Part number	Max. fuse size [A]	Part Number		
RGC2..10	40	A70QS40-4	32	50 142 06 32	100	600
RGC2..25	40	A70QS40-4	32	50 142 06 32	100	600
RGC2..40	60	A70QS60-4	63	50 194 20 63	100	600
RGC2..75	100	A70QS100-4	125	50 196 20 125	100	600
RGC3..10	40	A70QS40-4	32	50 142 06 32	100	600
RGC3..20	40	A70QS40-4	32	50 142 06 32	100	600
RGC3..25	40	A70QS40-4	32	50 142 06 32	100	600
RGC3..30	40	A70QS40-4	40	50 194 20 40	100	600
RGC3..40	50	A70QS50-4	50	50 194 20 50	100	600
RGC3..65	100	A70QS100-4	125	50 196 20 125	100	600

Suitable for heater load applications

Part No.	Ferraz Shawmut (Mersen)		Siba		Short circuit current [kArms]	Voltage [VAC]
	Max. fuse size [A]	Part number	Max. fuse size [A]	Part Number		
RGC2..10 RGC2..25	40	660 URC 14x51/40	32	50 142 06 32	10	600
	40	6.9xx gRC URD 22x58/40				
	40	660 URD 22x58/40			100	
	40	A70QS40-4				
RGC2..40	63	6.9xx gRC URC 14x51/63	63	50 194 20 63	10	600
	63	6.9xx gRC URD 22x58/63			100	
	60	A70QS60-4				
RGC2..75	100	6.9xx gRC URD 22x58/100	125	50 196 20 125	10	600
	100	660 URQ 27x60/100			100	
	100	A70QS100-4				
RGC3..10 RGC3..20	32	6.9xx gRC URC 14x51/32	32	50 142 06 32	10	600
	32	6.9xx gRC URC 14x51/32			100	
	40	A70QS40-4				
RGC3..25	40	660 URC 14x51/40	32	50 142 06 32	10	600
	40	6.9xx gRC URD 22x58/40				
	40	660 URD 22x58/40			100	
	40	A70QS40-4				
RGC3..30	40	6.9xx gRC URC 14x51/40	40	50 194 20 40	10	600
	40	6.9xx gRC URC 14x51/40			100	
	40	A70QS40-4				
RGC3..40	63	6.9xx gRC URC 14x51/63	50	50 194 20 50	10	600
	63	6.9xx gRC URC 22x58/63			100	
	50	A70QS50-4				
RGC3..65	100	6.9xx gRC URC 22x58/100	125	50 196 20 125	10	600
	90	660 URD 22x58/90			100	
	100	A70QS100-4				

## Type 2 Protection Coordination with Miniature Circuit Breakers (M.C.Bs)

Solid State Relay type	ABB Model no. for Z - type M. C. B. (rated current)	ABB Model no. for B - type M. C. B. (rated current)	Wire cross sectional area [mm <sup>2</sup> ]	Minimum length of Cu wire conductor [m] <sup>15</sup>
RGC2..10 RGC2..25 RGC3..10 RGC3..20 (1800A <sup>2</sup> s)	S201 - Z10 (10A)	S201 - B4 (4A)	1.0 1.5 2.5	7.6 11.4 19.0
	S201 - Z16 (16A)	S201 - B6 (6A)	1.0 1.5 2.5 4.0	5.2 7.8 13.0 20.8
	S201 - Z20 (20A)	S201 - B10 (10A)	1.5 2.5	12.6 21.0
RGC2..40 RGC3..25 RGC3..30 RGC3..40 (6600A <sup>2</sup> s)	S201 - Z25 (25A)	S201 - B13 (13A)	2.5 4.0	25.0 40.0
	S201 - Z20 (20A)	S201 - B10 (10A)	1.5 2.5 4.0	4.2 7.0 11.2
	S201 - Z32 (32A)	S201 - B16 (16A)	2.5 4.0 6.0	13 20.8 31.2
RGC2..75 RGC3..65 (15000A <sup>2</sup> s)	S201 - Z25 (25A)	S201 - B16 (16A)	2.5 4.0	3.1 5.0
	S201 - Z50 (50A)	S201 - B25 (25A)	6.0	7.5
			4.0	8.0
			6.0 10.0 16.0	12.0 20.0 32.0
	S201 - Z63 (63A)	S201 - B32 (32A)	6.0 10.0 16.0	11.3 18.8 30.0

15: Between MCB and Load (including return path which goes back to the mains if applicable)

Note: A prospective current of 6kArms and a 230/400V power supply system is assumed for the above suggested specifications. For cables with different cross section than those mentioned above please consult Carlo Gavazzi's Technical Support Group.

## Accessories

### Fan



### Ordering Key

**RGC3FAN60**

Fan accessory  
for RGC2..75 and RGC3..65

### Ordering Key

**RGC3FAN40**

Fan accessory  
for RGC3..40

## Environmental Information

The declaration in this section is prepared in compliance with People's Republic of China Electronic Industry Standard SJ/T11364-2014: Marking for the Restricted Use of Hazardous Substances in Electronic and Electrical Products.

Part Name	Toxic or Harardous Substances and Elements					
	Lead (Pb)	Mercury (Hg)	Cadmium (Cd)	Hexavalent Chromium (Cr(VI))	Polybrominated biphenyls (PBB)	Polybrominated diphenyl ethers (PBDE)
Power Unit Assembly	x	○	○	○	○	○

O: Indicates that said hazardous substance contained in homogeneous materials for this part are below the limit requirement of GB/T 26572.

X: Indicates that said hazardous substance contained in one of the homogeneous materials used for this part is above the limit requirement of GB/T 26572.

## 环境特性

这份申明根据中华人民共和国电子工业标准 SJ/T11364-2014：标注在电子电气产品中限定使用的有害物质

零件名称	有毒或有害物质与元素					
	铅 (Pb)	汞 (Hg)	镉 (Cd)	六价铬 (Cr(VI))	多溴化联苯 (PBB)	多溴联苯醚 (PBDE)
功率单元	x	○	○	○	○	○

O: 此零件所有材料中含有的该有害物低于GB/T 26572的限定。

X: 此零件某种材料中含有的该有害物高于GB/T 26572的限定。

