

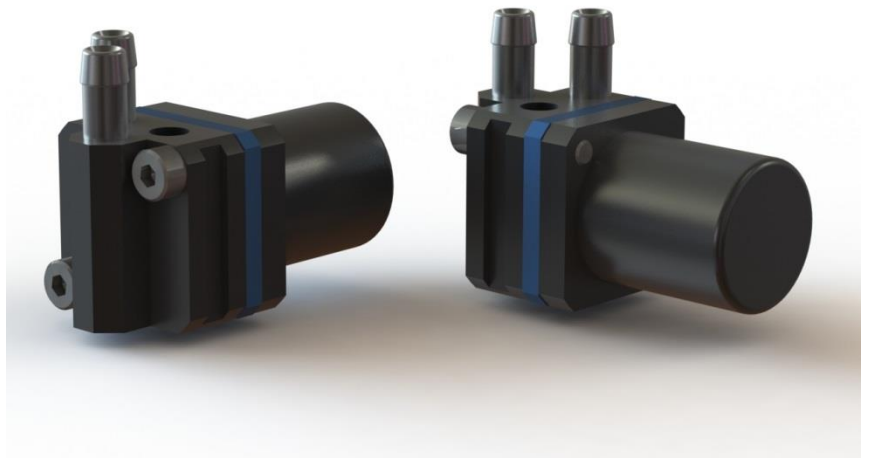

Professionally approved products.

Product Datasheet

RS-M100S Waterproof Micro pump

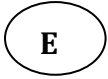



RS, Professionally Approved Products, gives you professional quality parts across all products categories. Our range has been testified by engineers as giving comparable quality to that of the leading brands without paying a premium price.

RS-M100s Waterproof Micro pump

The M100 series range of pumps are constructed from precision CNC machined aluminium alloy with stainless steel tubing connectors. The M100 range is fitted with Viton seals as standard. Alternative seal materials and optional wetted part coatings and materials are also available enabling this pump range to resist most chemicals and solvents. The pump uses efficient push fit connectors designed for 2.4mm bore flexible tubing. A 220mm electrical fly-lead is fitted as standard.

Standard features:

- CNC aluminium alloy construction
- Quiet pulseless smooth flow
- Small size only 28 x 14 x 14 mm
- Weight 10g
- Free flow up to 400ml per minute (water)
- Operating Temp -20 to 100 deg C
- Power by Solar supply, PSU or batteries
- Smooth pulseless flow
- IP Rating IP67
- Noise Levels >1dB

Typical Applications

- Medical devices
- Lubrication systems
- Fuel Cells
- Battery and Solar Powered Systems
- Cooling Systems

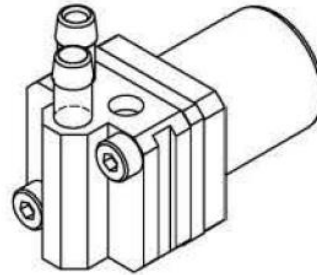
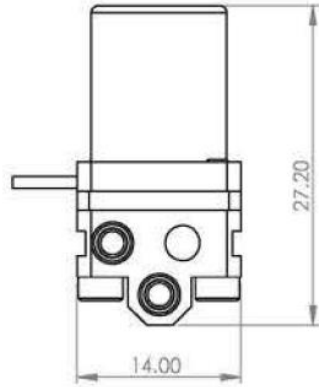

Connectors to suit 2.4mm bore tubing

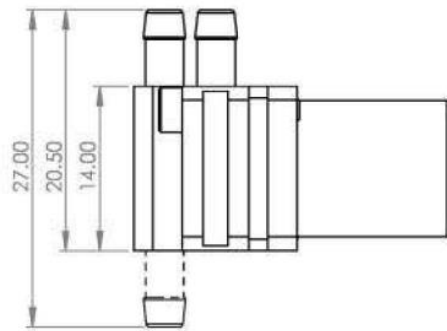
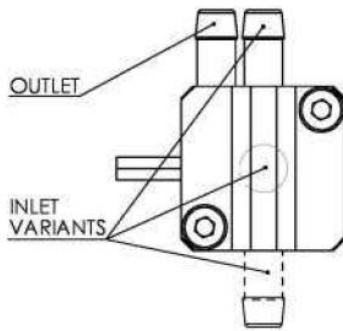

Variant	Input	Power	Flow	Pressure
	(V)	(W)	(ml/min)	(mBar)
M100S	2	0.36	125	34
	3	0.78	270	65
	4.5	1.85	400	155

