



Professionally approved products.

Instruction Sheet

(Original Instructions)

Tool Balancer

793-2774

793-2777

793-2771



• Caution:

- Improper use may cause harm to the user or damage to the tool balancer
- The Balancer can not be used for person under overloading for a long period



Declaration of Conformity CE

We (Kaisertech Limited) declare under our sole responsibility that the products Spring Balancers described under this manual are in conformity with the following Directives/ or standardization documents: Machinery Directive 2006/42/EC

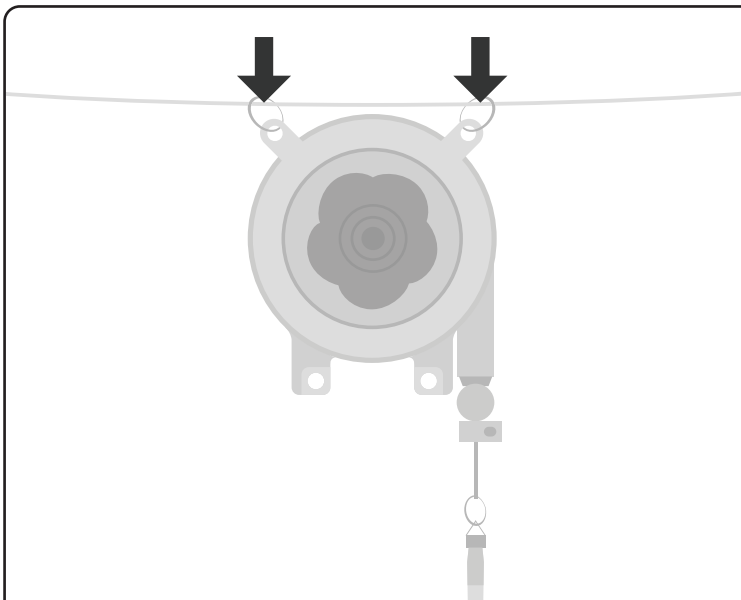

1. Two rings of the balancer need to be hanged above the working place to avoid dropping or tilting.

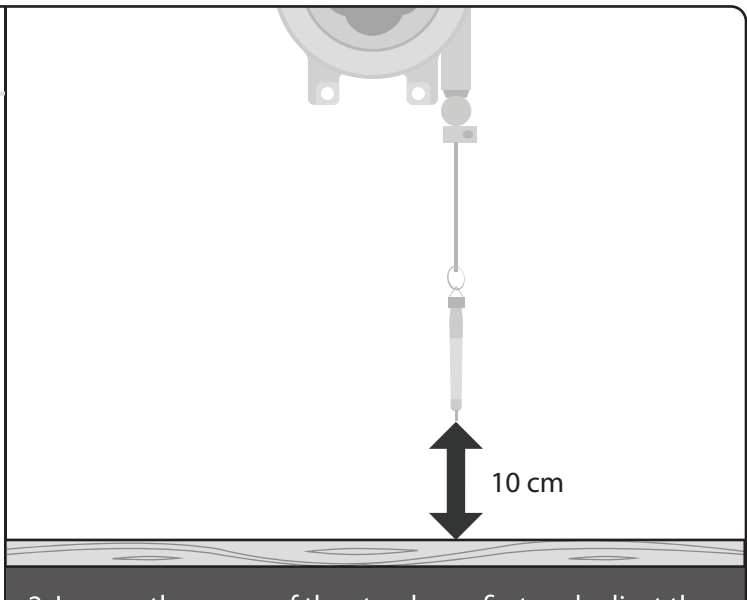

2. Loosen the screw of the steady ear first and adjust the distance between the screwdriver and the fastened item to about 10 cm.

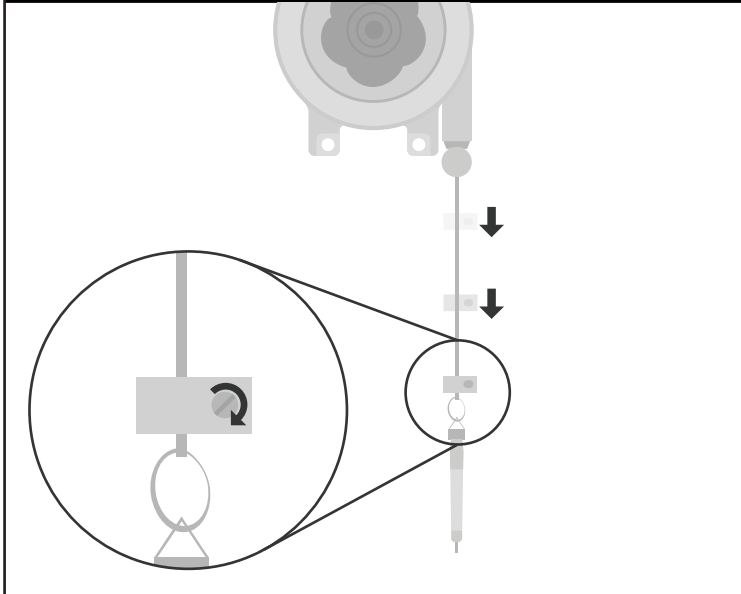

3. Move the steady ear towards the mouth of the balancer and fasten the screw.

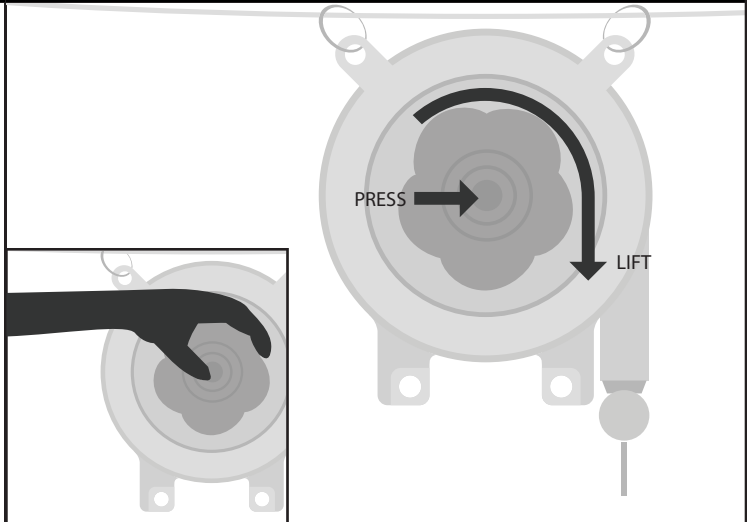

4. Press the rotator cover of the balancer with your thumb and lift up the rotator with your index and middle fingers. Turning clockwise will release the cord whereas turning counter-clockwise will fasten the cord.

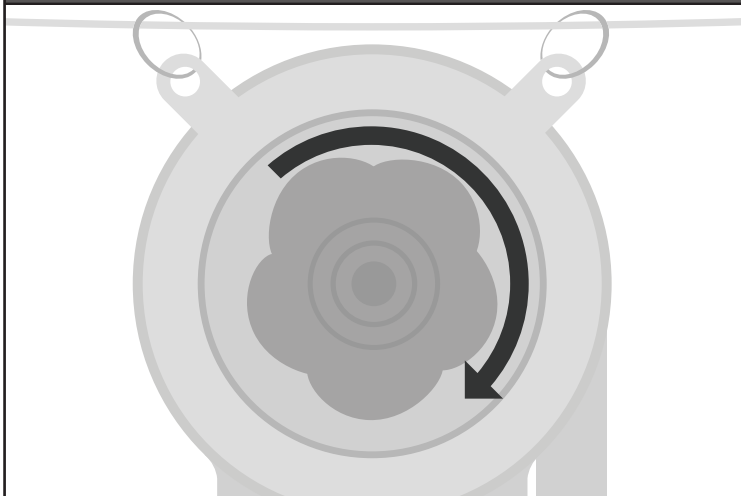

5. You can adjust the tensile level of the balancer by turning the rotator before use to avoid elastic fatigue which is caused by overload.
Counter clockwise rotation for a tension increase; clockwise for a tension release.

Model No.	Load		Extend Length
	kgs	lbs	
SB 1.2	0.5-1.2	1.1-2.6	1.6M
SB 2.0	1.0-2.0	2.2-4.4	
SB 3.0	2.0-3.0	4.4-6.6	

Noise Level; The sound level of balancer is below 70 dB(A) during use