

Vacuum Unit

Vacuum Ejector

Vacuum Pump System

New



RoHS

Energy-saving Ejector

Digital pressure switch for vacuum with energy saving function cuts supply air when the pressure reached the desired vacuum.

Air consumption **90% reduced**

More efficient ejector

Suction flow **50% increased**

Air consumption **30% reduced**

(Compared to other SMC single stage ejectors)

Two-stage ejector

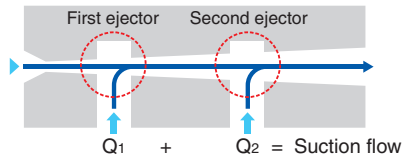

Compact / Lightweight

Volume **88 cm³** **28% reduced**

Weight **81g** **59% reduced**

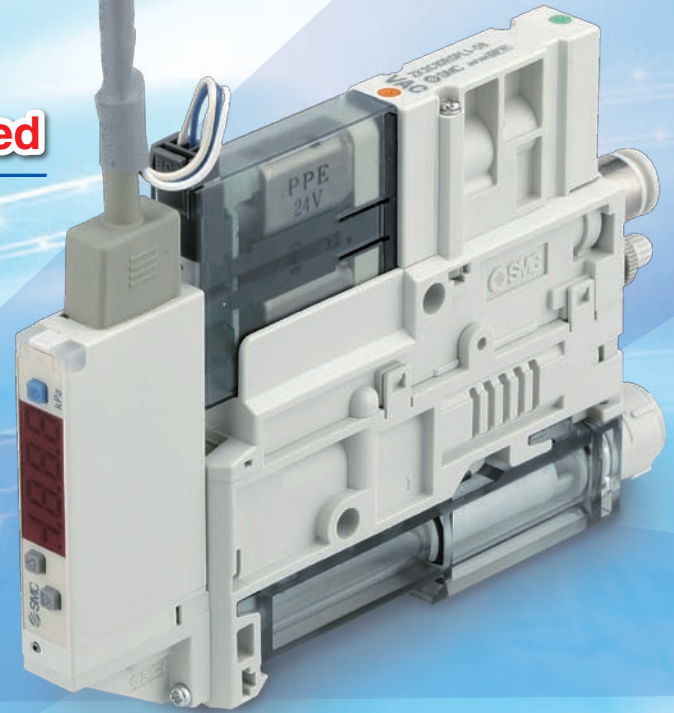

Reduced-wiring

D-sub connector



Flat ribbon cable



Individual wiring

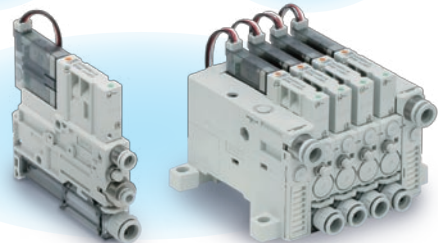

Individual wiring 1 connector

Three wires (for supply valve, release valve and COM) for one connector

Existing product

Individual wiring is required for supply valve, release valve.

Series **ZK2**



CAT.ES100-102A

Energy saving efficiency

Power consumption cost per year

Cost reduction by **70,594 yen/year**

Power consumption of existing product: 75,938 yen/year for 18,750 of total operation hours.

Ejector with energy saving function: 5,344 yen/year for 1,875 of total operation hours. Cost reduction by 90% (70,594 yen/year).

		Ejector with energy saving function	Existing product	Symbol and formula
Calculation conditions	Part number	ZK2A12K5KW-08	ZM131AM-K5LZ-E15	
	Air consumption	58 L/min (ANR)	85 L/min (ANR)	A
	Suction flow	61 L/min (ANR)	44 L/min (ANR)	For reference (ZK2 > ZM)
	Supply pressure	0.35 MPa		B
	Electric power cost	15 yen/kWh		C
Operation model	Adsorption time *1	0.6 sec/cycle	6 sec/cycle	D
	Operation frequency	450 cycle/h		E
	Operating time (hours)	10 h/day		F
	Operating period (days)	250 days/year		G
	Quantity	10 units		H
Compressor	Total operating time per year	1,875 h/year	18,750 h/year	$I = D \times E \times F \times G \times H \div 3600$
	Air consumption (per unit)	0.058 m³/min (ANR)	0.085 m ³ /min (ANR)	$J (= \text{Unit of conversion of A})$
	Air consumption (for total operation)	6,525 m³/year	95,625 m ³ /year	$K = J \times 60 \times I$
	Power consumption *2	0.19 kW	0.27 kW	$L (\text{Theoretical value obtained from A and B})$
	Power consumption cost per year	5,344 yen/year	75,938 yen/year	$M = C \times I \times L$

*1 Adsorption time is the time in a cycle when the ejector supply valve is ON and vacuum is generated. The supply valve of the ejector with energy saving function is OFF after confirming the adsorption. The supply valve of the existing ejectors remains ON.

*2 Power consumption of the compressor is obtained by theoretical formula based on flow consumption and supply pressure.

Energy-saving ejector

Digital pressure switch with energy saving function reduces air consumption by **90%*** or more.

When the vacuum pressure reaches the set pressure, the pressure switch turns off the supply valve. When the vacuum pressure decreases, the pressure switch turns the supply valve on and automatically controls it to maintain the vacuum pressure.

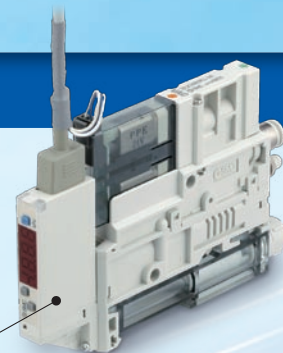

Digital pressure switch for vacuum with energy saving function

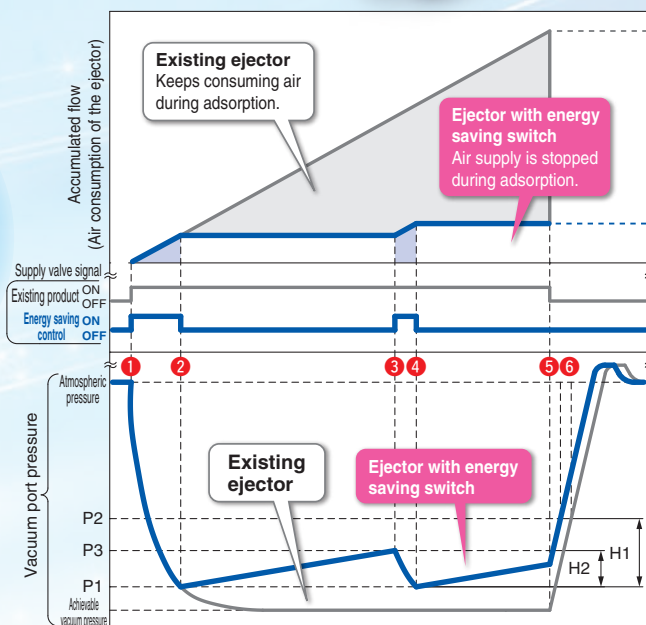
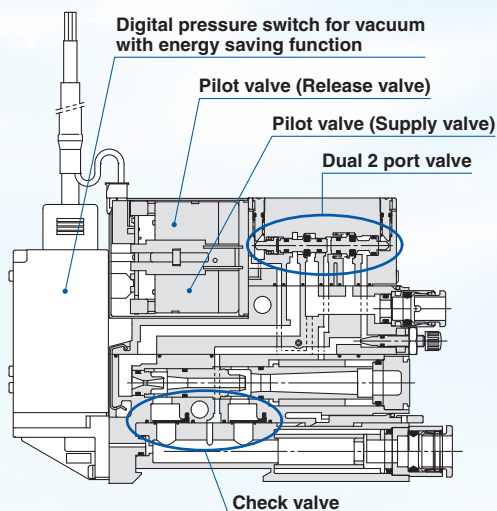
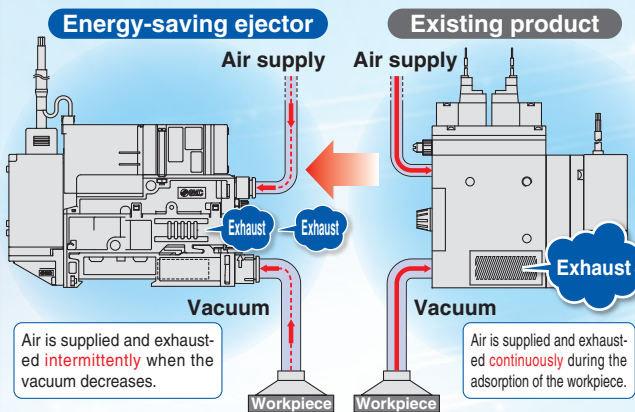

Operation	Supply valve
1 Vacuum generation	ON
2 Vacuum pressure (P1) reached	OFF
Vacuum maintained	OFF
3 Vacuum pressure decreased (P3)	ON
4 Vacuum pressure (P1) reached again	OFF
Vacuum maintained	OFF
5 Release of workpiece after adsorption and transfer ^(*)	OFF
6 Pressure at which adsorption completed reached (P2)	OFF

(* Release valve ON)

Dual 2 port valve (Release valve/Supply valve)

■ Supply valve: Self-holding type (Dual 2 port valve)

Even if there is a power cut, the vacuum is maintained as long as there is supply air.

- ① The vacuum is maintained during power failure as long as air is supplied. This can prevent the workpiece from being dropped.
- ② The unit turns on by instantaneous energizing (minimum 20 ms.). Continuous energizing is not necessary. This can reduce the power consumption.

■ Linked type supply and release valves operation

The self-holding type supply valve will be turned off by turning on the release valve. It is not necessary to send a signal to stop the vacuum, which simplifies the wiring and programming. (Conventional double solenoid and latching type require a signal to stop the vacuum.)

■ Power saving pilot valve

Supply and release valve are low power consumption type. **(0.35 W)**

When energy saving switch is built-in, supply valve (N.C) and release valve (N.C) are used together so that the supply valve stops without releasing the vacuum. (in order to achieve energy saving effect)

Pressure sensor/switch

Variations

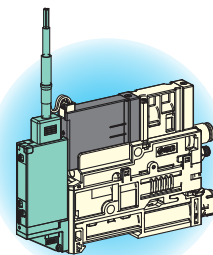

With digital pressure switch for vacuum with energy saving function

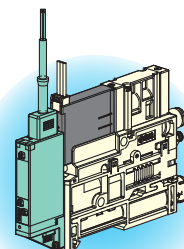

Digital pressure switch for vacuum

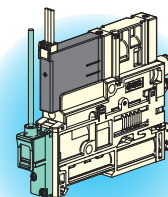

Pressure sensor

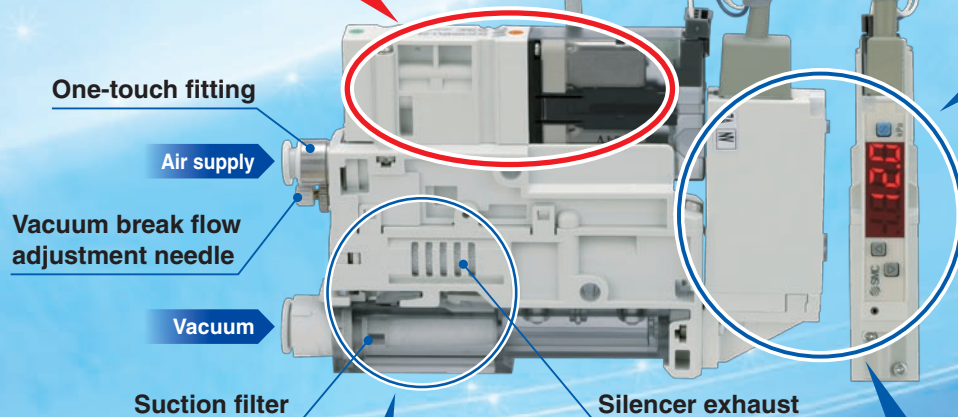

Easier maintenance

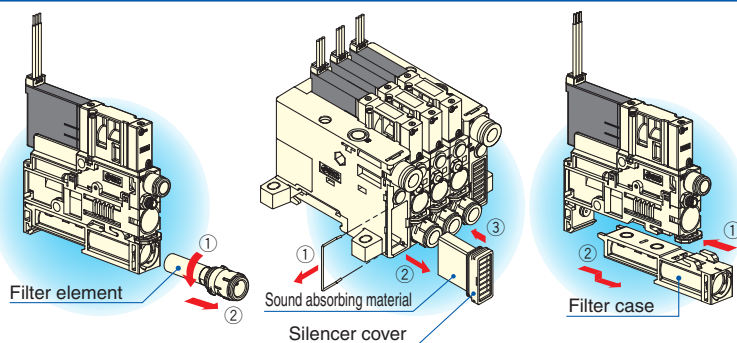

- Transparent filter case allows visual check of the contamination.
- Filter element and the sound absorbing material can be installed/removed without using screws.
- If there is dirt inside the case, it is possible to remove the case and clean it.

Digital pressure switch for vacuum

■ Set value copy function:

Reduction in setting work/Prevention of mistakes in setting

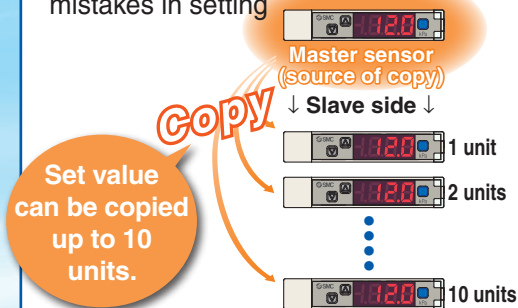

Mounting

■ Option Single unit bracket mounting

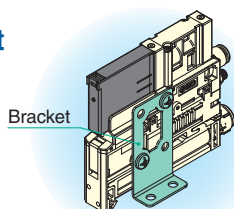

Single unit DIN rail mounting

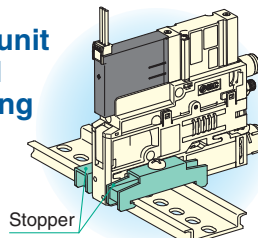

Manifold DIN rail mounting

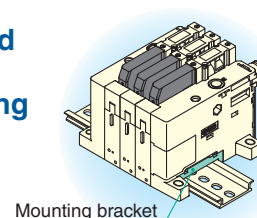

Single Unit Variations

Vacuum Ejector

Nozzle size

ø0.7, ø1.0, ø1.2, ø1.5

Air pressure supply (PV) port

ø6, ø1/4" One-touch fittings

Vacuum break flow adjustment needle

Round lock nut type
(Option)

Screwdriver operation type
(Option)

Vacuum (V) port

ø6, ø8 One-touch fittings
ø1/4", ø5/16" One-touch fittings

Vacuum switch

- Pressure sensor
- Pressure switch for vacuum
- Pressure switch for vacuum with energy saving function
- Without vacuum switch

Combination of supply valve and release valve

Supply valve	Release valve
N.C	N.C
N.C	None
Self-holding release valve linked	N.C
None	None

Supply valve/Release valve: Rated voltage

12, 24 VDC

With individual release pressure supply (PD) port*

PD port (M3)

*Option

Vacuum Pump System

Vacuum pressure supply (PV) port

ø6, ø1/4" One-touch fittings

Pilot pressure supply (PS) port

ø4, ø5/16" One-touch fittings

Vacuum (V) port

ø6, ø8 One-touch fittings
ø1/4", ø5/16" One-touch fittings

Manifold Variations

Manifold stations

1 to 10 stations

Wiring type

- D-sub connector
- Flat ribbon cable
- Individual wiring

Exhaust type

- Silencer common exhaust
- Individual port exhaust

Air pressure supply (PV) port ø8, ø5/16"

- Common supply
- Individual supply (Option)

Vacuum pressure (PV) port ø8, ø5/16"

- Common supply

Individual wiring

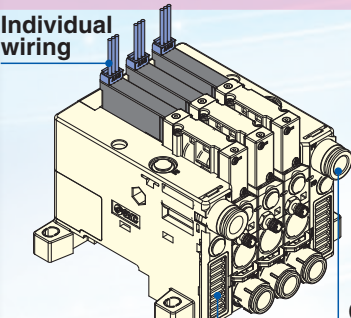

Silencer common exhaust

D-sub connector
Common air pressure supply (PV) port

Individual port exhaust

Individual air pressure supply (PV) port (Option)

Common pilot pressure supply (PS) port

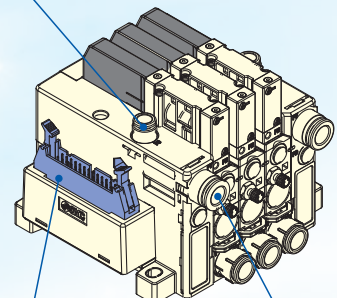

Flat ribbon cable connector

Common vacuum pressure supply (PV) port

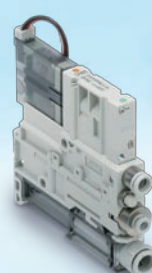
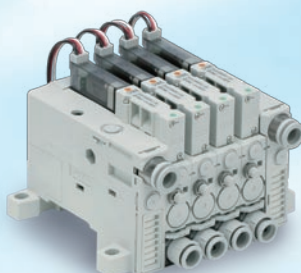

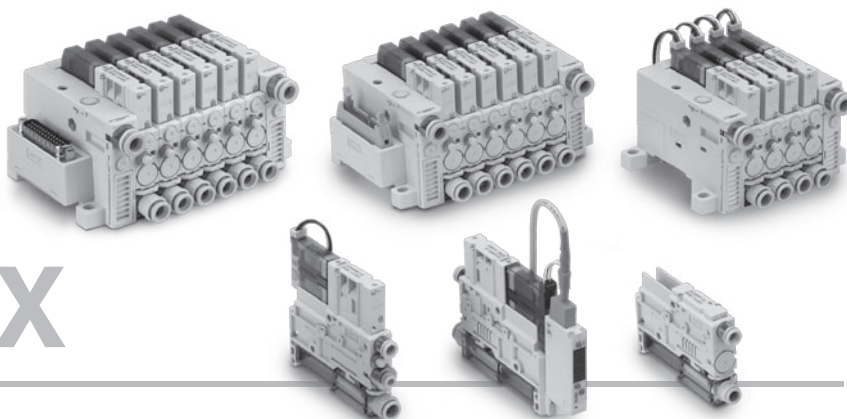

INDEX

How to Order

How to Order Single Unit	1
How to Order Manifold	3

Specifications/Flow-rate Characteristics

Specifications, Weight	5
Exhaust Characteristics, Flow-rate Characteristics	6
Vacuum Pump System Flow-rate Characteristics, Release Flow-rate Characteristics, How to Read Flow-rate Characteristics Graph	7
Pressure Sensor/Digital Pressure Switch for Vacuum Specifications	8
Digital Pressure Switch for Vacuum Specifications, Description, Internal Circuit and Wiring Example	9

Port Layout

Standard Products	10
Option -D	12
Option -L	14

Construction

Construction	15
How to Order Replacement Parts	16

Exploded View of Manifold

Dimensions

Specific Product Precautions

How to Order

Specifications/
Flow-rate Characteristics

Port Layout

Construction

Exploded View of Manifold

Dimensions

Specific Product Precautions

Vacuum Unit

Series ZK2



How to Order Single Unit

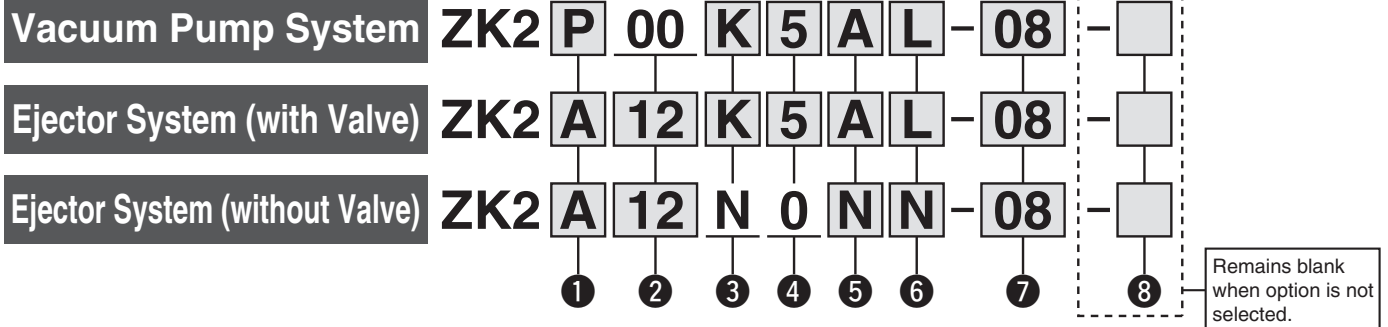

1 System/Body Type

Symbol	System	Body type	Exhaust type
P	Vacuum pump system	Single unit	—
Q		For manifold	—
A	Ejector system	Single unit	Silencer exhaust
B			Port exhaust
C		For manifold	Common Silencer exhaust
F	Individual port exhaust		

Note 1) PS port size of pump system: mm: $\phi 4$
inch: $\phi 5/32$ "
Port size of exhaust port: mm: $\phi 8$
inch: $\phi 5/16$ "

2 Nominal Nozzle Size

Symbol	System	Nominal size
00	Vacuum pump system	—
07	Ejector system ^{Note 2)}	$\phi 0.7$
10		$\phi 1.0$
12		$\phi 1.2$
15		$\phi 1.5$

Note 2) Standard supply pressure for nozzle size 07 to 12 is 0.35 MPa, 15 is 0.4 MPa

4 Rated Voltage ^{Note 8)}

Symbol	Voltage
5	24 VDC
6	12 VDC
0	When ③ is "N"

Note 8) Rated voltage for the supply and release valve

3 Combination of Supply Valve and Release Valve ^{Note 3)}

Symbol	Supply valve	Release valve
K	N.C.	N.C.
J	N.C. ^{Note 4)}	None
R	Self-holding release valve linked ^{Note 5)}	N.C.
N	None ^{Note 7)}	None

Note 3) Only non-locking type is available for the manual override for "K, J, R".
Note 4) When "J" is selected for vacuum pump system, install a release valve or vacuum breaker.
Note 5) Self-holding type maintains vacuum by instantaneous energization (20 ms or more). Stopping the vacuum turns on the release valve. (signal to stop vacuum not needed)
Note 6) When the digital pressure switch for vacuum with energy saving function is selected, select "K" for ⑤ Pressure Sensor/Digital Pressure Switch for Vacuum Specifications.
Note 7) Cannot be selected for vacuum pump system.

5 Pressure Sensor/Digital Pressure Switch for Vacuum Specifications

Symbol	Type	Pressure range [kPa]	Specifications	
P	Pressure sensor	0 to -101	Analog output 1 to 5 V	
T		-100 to 100	Analog output 1 to 5 V	
A	Digital pressure switch for Vacuum	0 to -101	NPN 2 outputs Unit selection function ^{Note 9)} SI unit only ^{Note 10)}	
B			-100 to 100	PNP 2 outputs Unit selection function ^{Note 9)} SI unit only ^{Note 10)}
C				100 to -100
D		Without pressure sensor/ Digital pressure switch for vacuum		
E			1 output Unit selection function ^{Note 9)} SI unit only ^{Note 10)}	
F				1 output Unit selection function ^{Note 9)} SI unit only ^{Note 10)}
H	1 output Unit selection function ^{Note 9)} SI unit only ^{Note 10)}			
J	Digital pressure switch for vacuum with energy saving function ^{Note 11)}	100 to -100	NPN 1 output Unit selection function ^{Note 9)} SI unit only ^{Note 10)}	
K			1 output Unit selection function ^{Note 9)} SI unit only ^{Note 10)}	PNP 1 output Unit selection function ^{Note 9)} SI unit only ^{Note 10)}
S				1 output Unit selection function ^{Note 9)} SI unit only ^{Note 10)}
N	Without pressure sensor/ Digital pressure switch for vacuum			

Note 9) Unit selection function is not available in Japan due to new measurement law.
Note 10) Fixed unit: kPa
Note 11) When "K, Q, R or S" is selected, select "K" for ③ Combination of Supply Valve and Release Valve. Select "W" for ⑥.

Vacuum Unit **Series ZK2**

- PV: Air pressure supply port/Port for vacuum source (Vacuum pump)
- PS: Pilot pressure supply port
- PD: Individual release pressure supply port
- V: Vacuum port ● EXH: Exhaust port
- PE: Pilot pressure exhaust port For details ⇒ Page 14

6 Supply Valve/Release Valve/Digital Pressure Switch for Vacuum Connector Specifications

Symbol	③ For supply valve/release valve ^{Note 12)}		⑤ Lead wire with connector for pressure switch/sensor ^{Note 15)}		Image	
	Connector type	Lead wire with connector				
C	Common wiring (Plug-in) (For manifold)	×	○ ^{Note 16)}	○ ^{Note 16)}		
C1			×	×		
L	L-type plug connector	○ ^{Note 13)}	○ ^{Note 16)}	○ ^{Note 16)}		
L1			×	○ ^{Note 16)}		
L2			○ ^{Note 13)}	×		
L3			×	×		
W			With lead wire for switch with energy saving function			
Y			Non-valve (without supply/release valve) When "N" is selected for ③		○ ^{Note 16)}	
Y1			×			
N	When "N" is selected for both ④ (Combination of Supply Valve and Release Valve) and ⑥ (Pressure Sensor/Pressure Switch for Vacuum Specifications) (without supply/release valve, without switch, pressure sensor)					

7 Vacuum (V) Port ^{Note 18)}

Symbol	Type	Port size	
06	Metric size	One-touch fitting	
08		One-touch fitting	
07	Inch size	One-touch fitting	
09		One-touch fitting	

Note 18) Supply port (PV) size of single unit: ø6 (mm), ø1/4" (inch)

- Note 12) Solenoid valve with light/surge voltage suppressor
 Note 13) Standard lead wire length for solenoid valve is 300 mm.
 Note 14) For lead wire lengths other than standard, select "L1 or L3", and order the connector assembly desired. (Refer to page 16.)
 Note 15) Standard lead wire length for pressure sensor is 3 m. Standard lead wire length with connector for switch for vacuum and the lead wire length for switch with energy saving function is 2 m.
 Note 16) Select "C, L, L1, Y" when the pressure sensor (P, T) is selected for ⑥ Pressure Sensor/Digital Pressure Switch for Vacuum Specifications. Since only grommet type is available for the pressure sensor, sensor without lead wire cannot be selected.
 Note 17) Select when no pressure switch for vacuum, pressure sensor, or pressure switch for vacuum with connector without lead wire is used.

Single Unit and Options ^{Note 26)}

ZK2	①	②	③	④	⑤	⑥	⑦	⑧										
								B	C	D	J	K	L	P	W			
	P	00	K	J	5	P ₁₀	J	06	●	●	●	●	●	●	●	●	●	●
	Q		R		6	N	L	08	●	●	●	●	●	●	●	●	●	●
	A	07	K	J	5	P ₁₀	J	07	●	●	●	●	●	●	●	●	●	●
	B	10	J	R	0	N	L	09	●	●	●	●	●	●	●	●	●	●
	C	12	R			C	N											
	F	15	N			N												

- Note 26) When "J or N" is selected for ④ Combination of Supply Valve and Release Valve, "J or K" cannot be selected for ⑧ Optional Specifications/Functions/Applications.
 For options not in the table, please contact SMC.
 Note 19) When more than one option is selected, list the option symbols in an alphabetical order. Example) -BJ
 Note 20) For an ejector, PE is common with EXH, so it is not necessary to specify the option. Thread size is M3.
 Note 21) Only M3 is available for PD port size. Use one-touch fitting (KJS series) or barb fitting (M series) for piping.
 Note 22) Select body for manifold. Select "L" for manifold type. When the common supply and individual supply are mixed, please contact SMC.
 Note 23) To prevent backflow of the manifold common exhaust, not for holding vacuum. This option does not completely stop the back flow of the exhaust air. Select port exhaust type depending on purpose.
 Note 24) When "-D" is selected for manifold option, select "-P" option for single unit model number.
 Note 25) When "J" is selected for ④ Combination of Supply Valve and Release Valve and "W" (exhaust interference prevention valve type) is selected for ⑧ Optional Specifications/Functions/Applications, install a release valve or vacuum breaker.

8 Optional Specifications/Functions/Applications ^{Note 19)}

Symbol	Type	Function/Application	Image
Nil	Without option	—	
B	With one bracket for mounting a single unit (Mounting screw is attached.)	• Use when a single unit is mounted to the floor in an upright position is requested. (When ordering only bracket, refer to page 22.)	
C	Pump system PE port female thread specification ^{Note 20)}	• Use for pilot pressure exhaust piping (Standard pump system is released to the atmosphere.)	
D	With individual release pressure supply (PD) port type ^{Note 21)}	• Use when supply pressure for vacuum release which pressure is different from the ejector supply pressure is requested.	
J	Vacuum break flow adjustment needle Round lock nut type	• Thicker than standard hexagon type. More suitable for hand tightening. • Round lock nut improves operability when manifold, pump system, or exhaust port type is used.	
K	Vacuum break flow adjustment needle Screwdriver operation type	• Slotted type improves fine adjustment performance when manifold, pump system, or exhaust port type is used.	
L	Manifold individual supply specification ^{Note 22)}	• Adjust the supply pressure individually for manifold in order to adjust the vacuum pressure reached by each ejector.	
P	Manifold common release pressure supply specification ^{Note 24)}	• When selecting "D" (with common release pressure supply (PD) port) for ⑤ manifold option, supplying a pressure which is different from common PV to common PD is requested.	
W	With exhaust interference prevention valve ^{Note 23, 25)}	• When ejectors are operated individually with silencer common exhaust manifold, exhausted air may flow backward from the V port of ejectors that are OFF. Exhaust interference prevention valve prevents back flow.	

Note) Refer to page 31 when mounting single unit to DIN rail.

How to Order Manifold

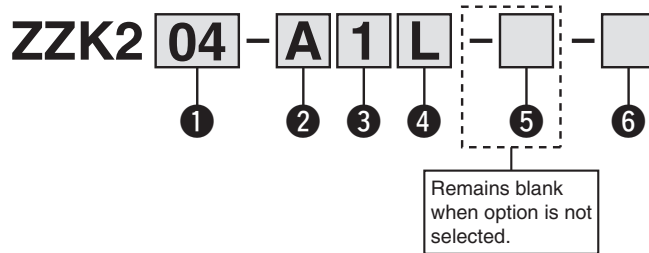

1 Stations Note 1)

Symbol	Stations
01	1 station
02	2 stations
⋮	⋮
10	10 stations

Note 1) In case of an ejector, for an adequate performance, the number of stations when operated simultaneously depends on the nozzle diameter. (Refer to Maximum Number of Manifold Stations that can Operate Simultaneously on page 5.)

2 System (Port combination) Note 2)

Symbol	System	Port	Standard	
P	Vacuum pump system	Common PV: $\phi 8$, Common PS: $\phi 6$ <small>Note 3)</small>	Metric size	
PN	Vacuum pump system	Common PV: $\phi 5/16"$, Common PS: $\phi 1/4"$ <small>Note 3)</small>	Inch size	
AN	Ejector system	Common PV: $\phi 5/16"$ <small>Note 4)</small>	Inch size	

Note 2) Refer to pages 10 to 14 for the port layout of standard port combinations and options.

Note 3) Common PS port and common PD port are connected inside. Connect one-touch fitting to one of ports so that piping becomes easier. (Connected to PS port initially)

Note 4) Common PV = Common PS = Common PD. Pressure is equal.

3 Exhaust

Symbol	Exhaust type		
2	Vacuum pump system	Without silencer	
1	Ejector system	Silencer common exhaust (End plate on both sides) <small>Note 5)</small>	
		Without silencer (Individual exhaust port) <small>Note 6)</small>	

Note 5) Select "C" for 1 System/Body Type on page 1.

Air is exhausted not only from the end plate, but also from the exhaust of each station.

Note 6) Select "F" for 1 System/Body Type on page 1.

4 Wiring Note 7)

Symbol	Type	
L	Individual wiring specification <small>Note 8)</small>	
F	D-sub connector (25 pins) <small>Note 9)</small>	
P	Flat ribbon cable (26 pins) <small>Note 9)</small>	
N	No wiring (No valve)	

Note 7) Common wiring is available only for solenoid valve wiring. Individual wiring is specified for vacuum switches and sensors.

Note 8) For 6 (connector type) of the single unit, select "L, L□, or W".

Note 9) For 6 (connector type) of the single unit, select "C, C1".

5 Option Note 10)

Symbol	Type
Nil	Without option
B	With DIN rail mounting bracket <small>Note 11)</small>
D	With common release pressure supply (PD) port <small>Note 12)</small>
L	Manifold individual supply specification <small>Note 13)</small>

Note 10) When more than one option is selected, list the option symbols in an alphabetical order.
Example) -BD

Note 11) DIN rail should be ordered separately. (Refer to page 17.)

Note 12) When "-D" is selected for manifold type, select "-P" option for ⑧ single unit model number. Refer to pages 10 to 14 for port layout.

Note 13) When "-L (individual supply)" option is selected for ⑧ single unit model number, specify "-L" for manifold.

6 Manifold Assembly (Delivery condition)

Symbol	Type
Nil	Individual units assembled delivered as a manifold
A	Delivered as individual parts (not assembled) <small>Note 14)</small>

Note 14) Kit consists of the end plates for both ends and tension bolts.

Manifold parts when not assembled

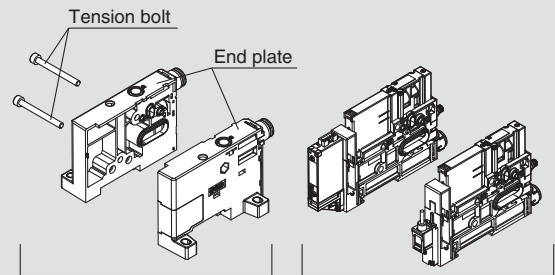

Manifold parts

Ejector: Single unit

ZZK202-A1L-A.....1 set (Manifold part number)
ZK2C10K5BL3-08.....1 set (Single unit part number)
ZK2C10K5PL1-08.....1 set (Single unit part number)

↳ Do not add "*"

How to Order Valve Manifold Assembly

Example

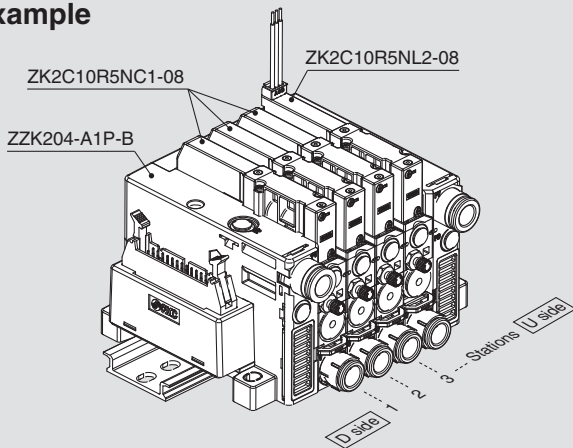

ZZK204-A1P-B.....1 set (Manifold part number)
* ZK2C10R5NC1-08.....3 sets (Common wiring specification)
* ZK2C10R5NL2-08.....1 set (Individual wiring specification)
↳ * The asterisk denotes the symbol for assembly.
* Prefix to the single unit part number.

- When the manifold is viewed from V port, the first station starts from the left (D side).
- After the manifold part number, specify the installed single unit from the first station.
- Common silencer exhaust and individual port exhaust cannot be mixed in the ejector system manifold.
- DIN rail should be ordered separately. (Page 17)

Manifold Type and Options

	①	②	③	④	⑤			⑥
					B	D	L	
ZZK2	01	P	2	L	●	●		Nil
	10	A	1	F	●	●	●	
		AN	2	P				A

Series ZK2

Specifications

General Specifications

Operating temperature range		-5 to 50°C (with no condensation)
Fluid		Air, Inert gas
Vibration resistance ^{Note 1)}	30 m/s ²	Without pressure sensor/switch for vacuum With pressure sensor
	20 m/s ²	With switch for vacuum
Impact resistance ^{Note 2)}	150 m/s ²	Without pressure sensor/switch for vacuum With pressure sensor
	100 m/s ²	With switch for vacuum

Note 1) 10 to 500 Hz for 2 hours in each direction of X, Y and Z (During de-energizing)

Note 2) 3 times in each direction of X, Y and Z (During de-energizing)

Valve Common Specifications

Valve model ^{Note 3)}	ZK2-VA□R	ZK2-VA□K	ZK2-VA□J
Type of actuation ^{Note 4)}	Self-holding supply valve Release valve N.C. (Linked)	Supply valve N.C. Release valve N.C.	Supply valve N.C. Without release valve
Valve configuration	Pilot operated dual 2 port		Pilot operated 2 port
Operating pressure range	0.3 to 0.6 MPa		
Valve construction	Poppet seal		
Manual override	Push type		
Rated voltage	24 VDC, 12 VDC		
Power consumption	0.35 W		

Note 3) Refer to ⑥ Valve assembly on page 16 for the valve model number.

Note 4) ZK2-VA□R: After instantaneous energization of the supply valve (20 ms or more), ON state is maintained without energization. Supply valve turns off simultaneously when the release valve turns on.

ZK2-VA□K: Supply valve turns off when is not energized. Select this type when energy saving switch is used.

Ejector Specifications

Item		Model	ZK2□07	ZK2□10	ZK2□12	ZK2□15
Nozzle diameter	[mm]		0.7	1.0	1.2	1.5
Max. suction flow ^{Note 5)}	Port exhaust specification	[L/min (ANR)]	34	56	74	89
	Silencer exhaust specification	[L/min (ANR)]	29	44	61	67
Air consumption ^{Note 5)}	[L/min (ANR)]		24	40	58	90
Maximum vacuum pressure ^{Note 5)}	[kPa]		-91			
Supply pressure range	[MPa]		0.3 to 0.6			
Standard supply pressure	[MPa]		0.35			0.4

Note 5) Values are based on standard of SMC measurements. They depend on atmospheric pressure (weather, altitude, etc.) and measurement method.

Maximum Number of Manifold Stations that can Operate Simultaneously ^{Note 6)}

Item		Model (Nozzle size)	ZK2□07	ZK2□10	ZK2□12	ZK2□15
Air pressure supply (PV) port ø8, ø5/16"	Common silencer exhaust	Supply from one side	8	5	4	3
		Supply from both sides	10	7	5	5
	Individual port exhaust	Supply from one side	8	6	6	3
		Supply from both sides	10	9	9	6

Note 6) As long as the number of stations operated simultaneously is the value on the table or less, then the manifold is available up to 10 stations.

Weight

Single Unit

Single unit model	Weight (g)
ZK2P00K□□ (Vacuum pump system, Single unit, Without pressure sensor/switch for vacuum)	83
ZK2A□□K□□ (Ejector system, Single unit, Without pressure sensor/switch for vacuum)	81
ZK2A□□NONN (Ejector system, Single unit, Without valve)	54
ZK2 (One station for manifold, Without pressure sensor/switch for vacuum)	85

Pressure Sensor/Pressure Switch for Vacuum

Pressure sensor/Pressure switch for vacuum model	Weight (g)
ZK2-PS□-A (Except cable portion)	5
ZK2-ZS□-A (Except lead wire assembly with connector)	14
ZK2-ZSV□-A (Except special lead wire assembly with connector)	

Manifold Base

	1 station	2 stations	3 stations	4 stations	5 stations	6 stations	7 stations	8 stations	9 stations	10 stations
Weight (g)	129	132	135	138	141	144	147	149	152	155

● Calculation of Weight for the Manifold Type

(Single unit weight x Number of stations) + (Pressure sensor/Pressure switch for vacuum weight x Number of stations) + Manifold base

Example) 5-station manifold with pressure sensors

$$85 \text{ g} \times 5 \text{ pcs.} + 5 \text{ g} \times 5 \text{ pcs.} + 141 \text{ g} = \boxed{591 \text{ g}}$$

Ejector Exhaust Characteristics/Flow-rate Characteristics

ZK2□07

Exhaust Characteristics

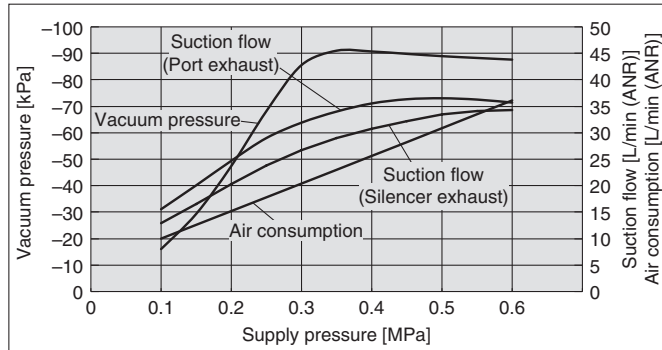

Flow-rate Characteristics

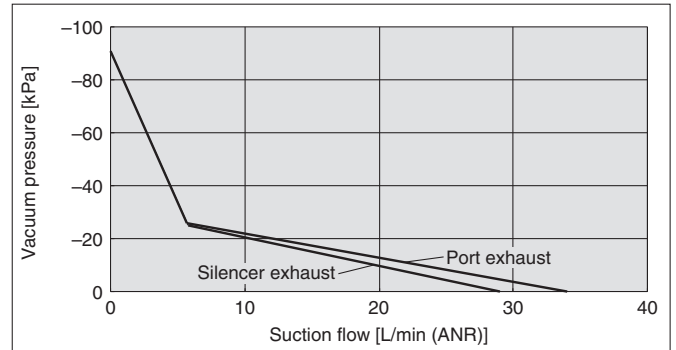

ZK2□10

Exhaust Characteristics

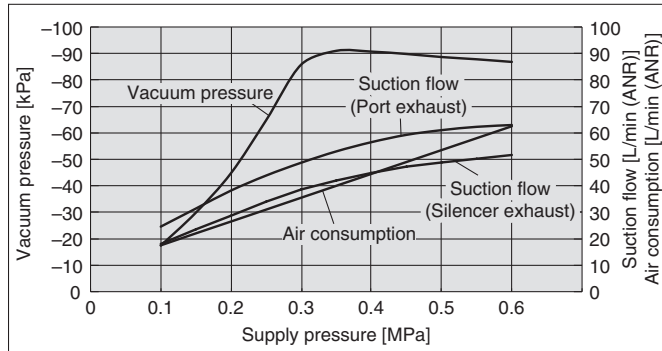

Flow-rate Characteristics

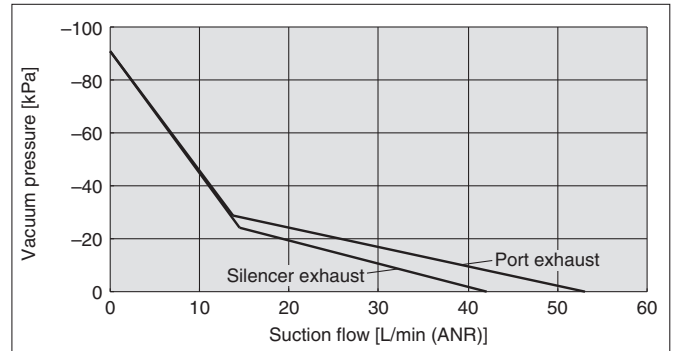

ZK2□12

Exhaust Characteristics

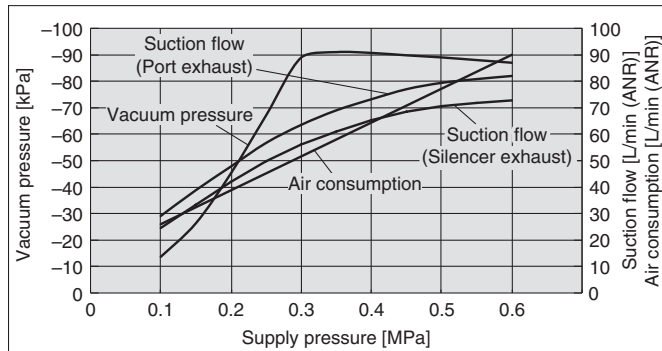

Flow-rate Characteristics

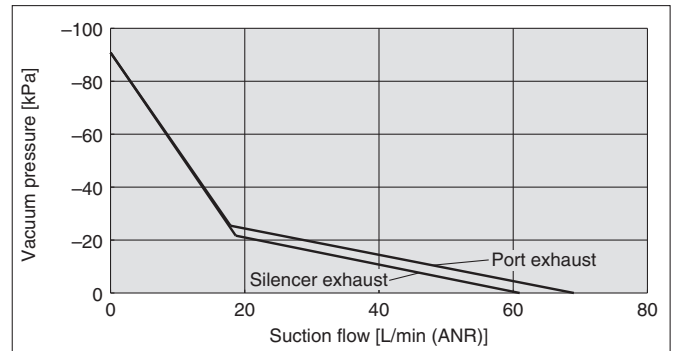

ZK2□15

Exhaust Characteristics

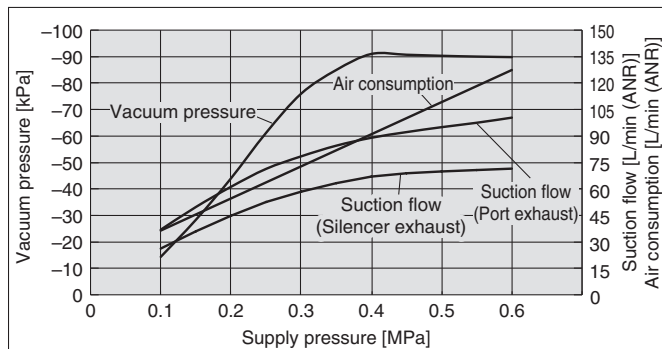

Flow-rate Characteristics

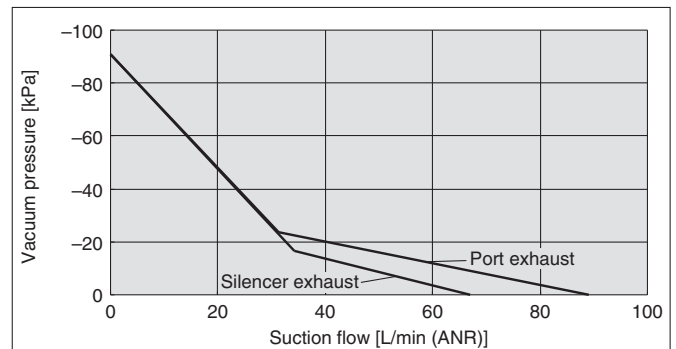

How to Order

Specifications/
Flow-rate Characteristics

Port Layout

Construction

Exploded View of Manifold

Dimensions

Specific Product Precautions

Series ZK2

Vacuum Pump System Flow-rate Characteristics/ZK2P00

The graph shows the suction flow-rate characteristics of the vacuum pump system at different vacuum pressures.

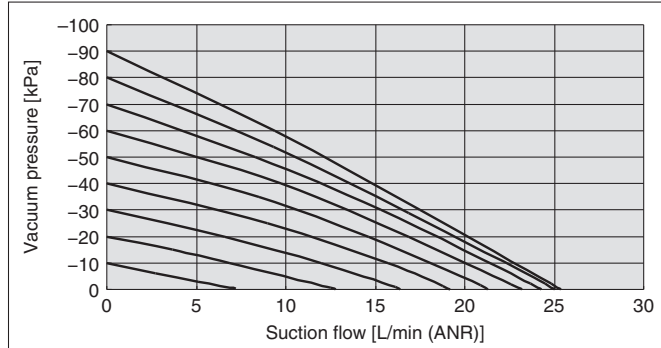

The actual suction flow at the point of suction varies depending on the piping conditions to the vacuum port. (The above graph shows the value when V port is ø8.)

Release Flow-rate Characteristics

The graph shows the flow-rate characteristics at different supply pressures when the vacuum break flow adjustment needle is opened from the fully closed state.

ZK2□□□(Ejector System)

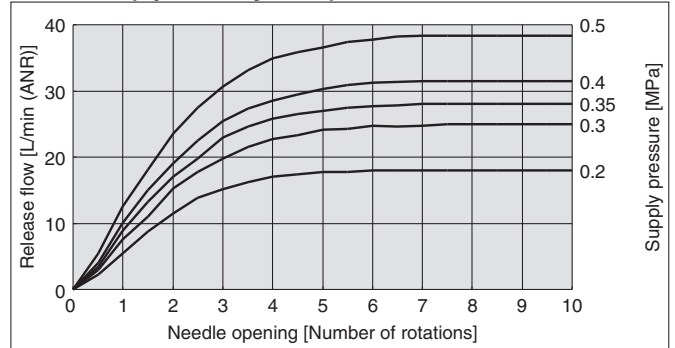

The actual suction flow at the point of suction varies depending on the piping conditions to the vacuum port. (The above graph shows the value of the ZK2B07.)

ZK2□□□(Pump System)

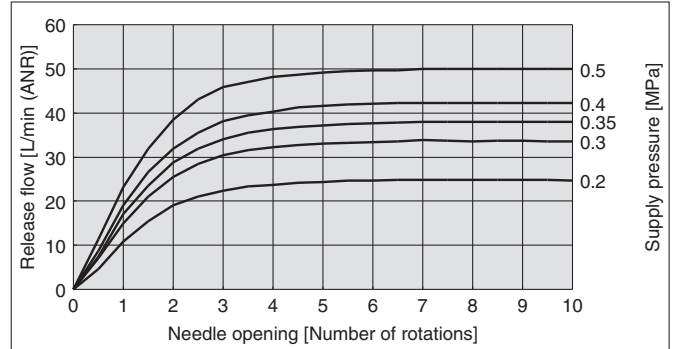

The actual suction flow at the point of suction varies depending on the piping conditions to the vacuum port.

Vacuum Pump System Flow-rate Characteristics of Flow Path and Vacuum Release

Port size		Flow-rate characteristics of V → PV (Vacuum side)			Flow-rate characteristics of PS → V (Vacuum release side) ^(*)		
PV port	V port	C[dm ³ /(s·bar)]	b	Cv	C[dm ³ /(s·bar)]	b	Cv
ø6	ø8	0.39	0.14	0.09	0.20	0.06	0.04

(*) When needle is fully open

How to Read Flow-rate Characteristics Graph

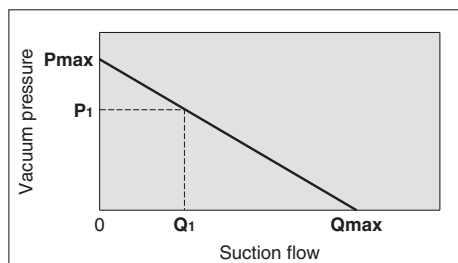

Flow-rate characteristics are expressed in ejector vacuum pressure and suction flow. If suction flow changes, the vacuum pressure will also be changed. Normally this relationship is expressed in ejector standard operating pressure use. In graph, **Pmax** is maximum vacuum pressure and **Qmax** is maximum suction flow. The values are specified according to catalog use. Changes in vacuum pressure are expressed in the below order.

1. When ejector suction port is covered and made airtight, suction flow becomes zero and vacuum pressure is at maximum value (**Pmax**).
2. When suction port is opened gradually, air can flow through, (air leakage), suction flow increases, but vacuum pressure decreases. (condition **P1** and **Q1**)
3. When suction port is opened further and fully opened, suction flow moves to maximum value (**Qmax**), but vacuum pressure is near zero (atmospheric pressure).

As described above, the vacuum pressure changes when the suction flow changes. In other words, when there is no leakage from the vacuum (V) port, the vacuum pressure can reach its maximum, but as the amount of leakage increases, the vacuum pressure decreases. When the amount of leakage and the maximum suction flow become equal, the vacuum pressure becomes almost zero. In the case when ventirative or leaky work should be adsorbed, please note that vacuum pressure will not rise.

Pressure Sensor/Digital Pressure Switch for Vacuum Specifications

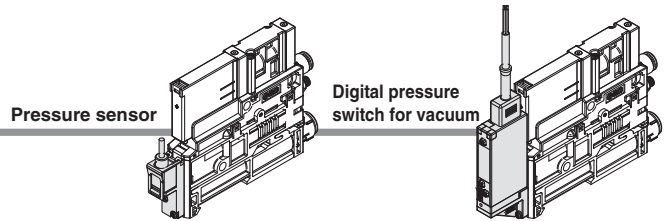

Pressure Sensor/ZK2-PS□-A (Refer to the PSE series in Best Pneumatics No. 6 and Operation Manual for details.)

Model (Sensor unit: Standard model number)	ZK2-PS1-A (PSE541)	ZK2-PS3-A (PSE543)
Rated pressure range	0 to -101 kPa	-100 to 100 kPa
Proof pressure	500 kPa	
Applicable fluid	Air/Non-corrosive gas/Incombustible gas	
Output voltage	1 to 5 VDC	
Output impedance	Approx. 1 kΩ	
Power supply voltage	10 to 24 VDC ±10%, Ripple (P-P) 10% or less	
Current consumption	15 mA or less	
Accuracy	±2% F.S. (Ambient temperature at 25°C)	
Linearity	±0.4% F.S. or less	
Repeatability	±0.2% F.S. or less	
Effect of power supply voltage	±0.8% F.S. or less	
Temperature characteristics	±2% F.S. or less (Ambient temperature: 25°C reference)	
Material	Case	Resin case
	Pressure sensing section	Sensor pressure receiving area: Silicon, O-ring: HNBR
Lead wire	Oilproof heavy-duty cable 2.7 x 3.2 mm (Elliptic), 0.15 mm ² 3 cores 3 m	

Digital Pressure Switch for Vacuum/ZK2-ZS□□□□-A (Refer to the individual catalog ZSE/ISE10 series and Operation Manual for details.)

Model (Switch unit: Standard model number)	ZK2-ZSE□□□□-A (ZSE10)	ZK2-ZSF□□□□-A (ZSE10F)
Rated pressure range	0 to -101 kPa	-100 to 100 kPa
Set pressure range/Pressure display range	10 to -105 kPa	-105 to 105 kPa
Proof pressure	500 kPa	
Minimum setting unit	0.1 kPa	
Applicable fluid	Air/Non-corrosive gas/Incombustible gas	
Power supply voltage	12 to 24 VDC ±10%, Ripple (p-p) 10% or less (Protected against reverse connection)	
Current consumption	40 mA or less	
Switch output	NPN or PNP open collector 2 outputs (selectable)	
	Maximum load current	80 mA
	Maximum applied voltage	28 V (with NPN output)
	Residual voltage	2 V or less (with load current at 80 mA)
	Response time	2.5 ms or less (Anti-chattering function working: 20, 100, 500, 1000 or 2000 ms selected)
	Short circuit protection	Yes
Repeatability	±0.2% F.S. ±1 digit	
Hysteresis	Hysteresis mode	Variable (0 or above) ^{Note)}
	Window comparator mode	
Display	3 1/2 digit, 7-segment LED, 1-color display (Red)	
Display accuracy	±2% F.S. ±1 digit (Ambient temperature at 25 ±3°C)	
Indicator light	Lights up when output is turned ON. OUT1: Green, OUT2: Red	
Environmental resistance	Enclosure	IP40
	Operating temperature range	Operating: -5 to 50°C, Storage: -10 to 60°C (with no freezing or condensation)
	Operating humidity range	Operating/Storage: 35 to 85% RH (with no condensation)
	Withstand voltage	1000 VAC for 1 minute between terminals and housing
	Insulation resistance	50 MΩ or more (500 VDC measured via megohmmeter) between terminals and housing
	Vibration resistance	10 to 150 Hz at whichever is smaller of 1.5 mm amplitude or 20 m/s ² , in X, Y, Z directions, for 2 hours each (De-energized)
Impact resistance	100 m/s ² in X, Y, Z directions, 3 times each (De-energized)	
Temperature characteristics	±2% F.S. (at 25°C in an operating temperature range of -5 and 50°C)	
Lead wire	Oilproof heavy-duty vinyl cable 5 cores, Cross section: 0.15 mm ² (AWG26), Insulator O.D.: 1.0 mm	
Standards	Compliant with CE marking, RoHS	

Note) If the applied voltage fluctuates around the set value, the hysteresis must be set to a value more than the fluctuating width, otherwise, chattering will occur.

How to Order

Specifications/
Flow-rate Characteristics

Port Layout

Construction

Exploded View of Manifold

Dimensions

Specific Product Precautions

Series ZK2

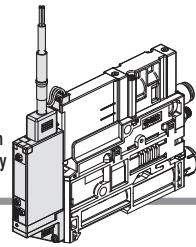

Digital pressure switch for vacuum with energy saving function

Digital Pressure Switch for Vacuum Specifications

Digital Pressure Switch for Vacuum Ejector with Energy Saving Function

Model		Specifications
Rated pressure range		100.0 to -100.0 kPa
Set pressure range		105.0 to -105.0 kPa
Proof pressure		500 kPa
Minimum setting unit		0.1 kPa
Applicable fluid		Air/Non-corrosive gas/Incombustible gas
Power supply voltage		24 VDC \pm 10% Ripple (P-P) 10% or less (Protected against reverse connection)
Current consumption		40 mA or less
Switch output		NPN or PNP open collector OUT1: General purpose, OUT2: Valve control
Maximum load current		80 mA
Maximum applied voltage		26.4 VDC
Residual voltage		2 V or less (with load current at 80 mA)
Response time		2.5 ms or less (Anti-chattering function working: 20, 100, 500, 1000 or 2000 ms selected)
Short circuit protection		Yes
Repeatability		\pm 0.2% F.S. \pm 1 digit
Hysteresis	Hysteresis mode	Variable (0 or above) <small>Note)</small>
Display		3 1/2 digit, 7-segment LED, 1-color display (Red)
Display accuracy		\pm 2% F.S. \pm 1 digit (Ambient temperature at 25 \pm 3°C)
Indicator light		Lights up when output is turned ON. OUT1: Green, OUT2: Red
Enclosure		IP40
Environmental resistance	Operating humidity range	5 to 50°C
	Withstand voltage	1000 VAC for 1 minute between terminals and housing
	Insulation resistance	50 M Ω or more (500 VDC measured via megohmmeter) between terminals and housing
Temperature characteristics		\pm 2% F.S. (at 25°C in an operating temperature range of 5 and 50°C)
Lead wire		Cable: 5 cores ϕ 3.5, 2 m Cross section: 0.15 mm ² (AWG26) Insulator O.D.: 1.0 mm
Standards		CE marking, RoHS

Note) If the applied voltage fluctuates around the set value, the hysteresis must be set to a value more than the fluctuating width, otherwise, chattering will occur.

Description (Pressure Switch for Vacuum)

Output (OUT1) display (Green)	Lights up when OUT1 is turned ON.
Output (OUT2) display (Red)	Lights up when OUT2 is turned ON.
LED display	Displays the current pressure, set mode and error code. Selects the mode or increases the ON/OFF set-value.
▲ button (UP)	Use for switching to the peak display mode.
▼ button (DOWN)	Use for switching to the bottom display mode.
Ⓢ button (SET)	Use for changing the mode or setting the set-value.

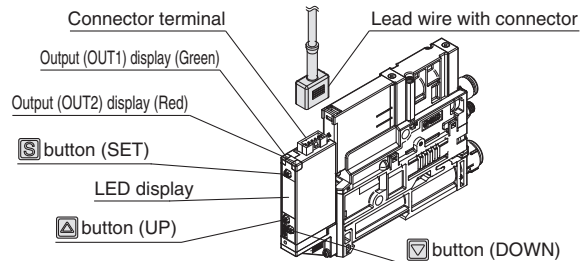

Internal Circuit and Wiring Example

■ Pressure Sensor ZK2-PS□□-A

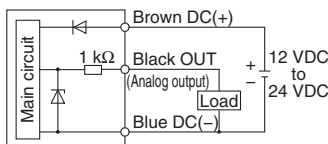

Voltage output type: 1 to 5 V
Output impedance: Approx. 1 k Ω

■ Pressure Switch for Vacuum ZK2-ZS□□A□□-A NPN (2 Outputs)

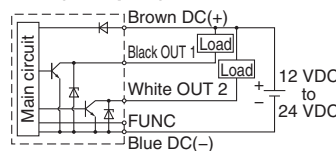

Max. 28 V, 80 mA
Residual voltage: 2 V or less

ZK2-ZS□□B□□-A PNP (2 Outputs)

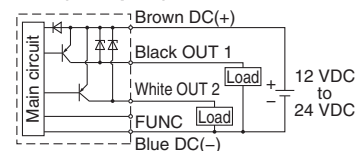

Max. 80 mA
Residual voltage: 2 V or less

* The FUNC terminal is connected when using the copy function. (Refer to the Operation Manual.)

■ Pressure Switch for Vacuum with Energy Saving Function ZK2-ZSVA□□-A NPN (Output)

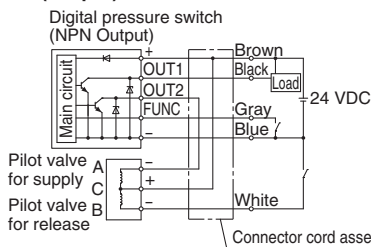

Connector cord assembly (ZK2-LWA20-A)

ZK2-ZSVB□□-A PNP (Output)

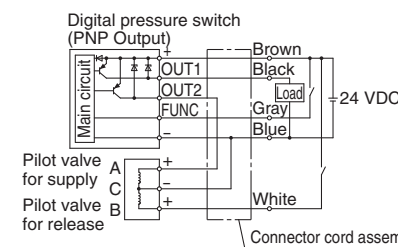

Connector cord assembly (ZK2-LWB20-A)

Port Layout

System depends on vacuum source (vacuum pump/vacuum ejector).

Standard Products

Port layout No. **1**

Single unit: ZK2P00□□□□-□

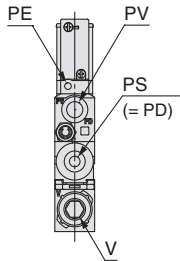

System	Vacuum pump	
Body type	Single unit	
Exhaust type	Without silencer	
Application and purpose	Vacuum pressure	—
	Exhaust	—
	Release pressure	Same pressure as PS

Port combination: PV ≠ PS = PD

Circuit example

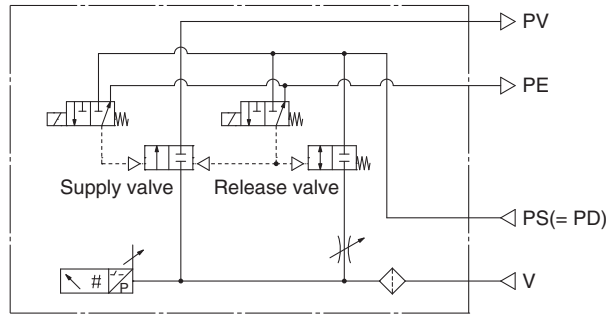

Supply valve: Self-holding type Release valve: N.C. (R type)

Port layout No. **2**

Single unit: ZK2Q00□□□□-□
Manifold: ZK2□□-P2□

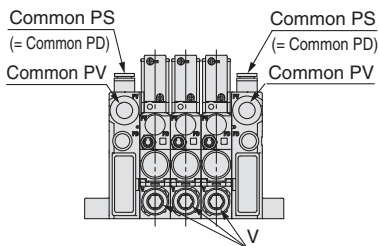

System	Vacuum pump	
Body type	Manifold	
Exhaust type	Without silencer	
Application and purpose	Vacuum pressure	Common for each station
	Exhaust	—
	Release pressure	Same pressure as common PS

Port combination: Common PV ≠ Common PS = Common PD

Circuit example

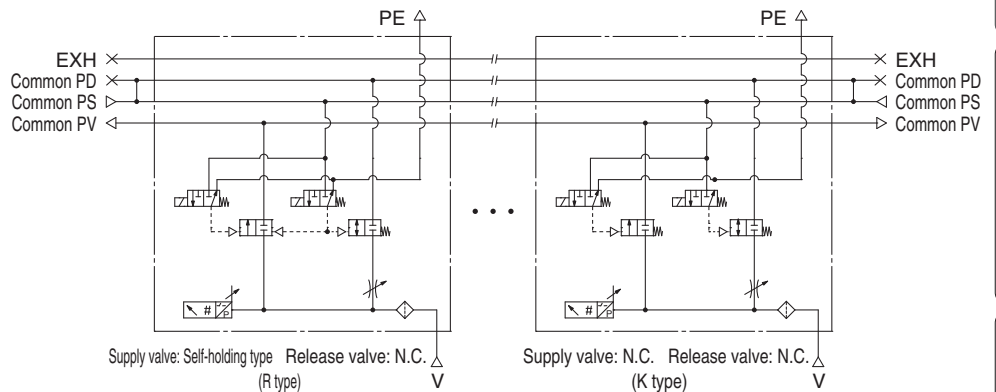

Supply valve: Self-holding type Release valve: N.C. (R type)

Supply valve: N.C. Release valve: N.C. (K type)

Port layout No. **3**

Single unit: ZK2A□□□□□□-□

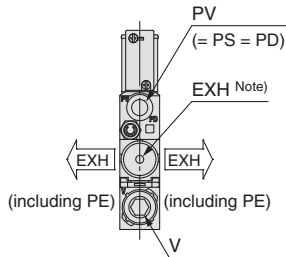

System	Ejector	
Body type	Single unit	
Exhaust type	Silencer exhaust	
Application and purpose	Vacuum pressure	—
	Exhaust	Released in operating environment
	Release pressure	Same pressure as PV

Port combination: PV = PS = PD

Circuit example

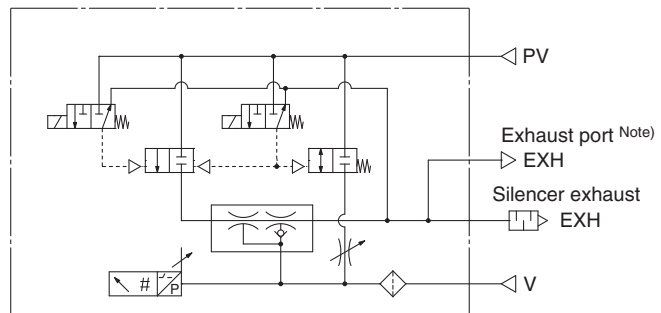

Supply valve: Self-holding type Release valve: N.C. (R type)

Note) Nozzle size: 12, 15

How to Order

Specifications/
Flow-rate Characteristics

Port Layout

Construction

Exploded View of Manifold

Dimensions

Specific Product Precautions

Refer to page 14 for the purpose of port and the operating pressure range.

Series ZK2

Port Layout

System depends on vacuum source (vacuum pump/vacuum ejector).

Standard Products

Port layout No. **4**

Single unit: ZK2B□□□□□□□□□□

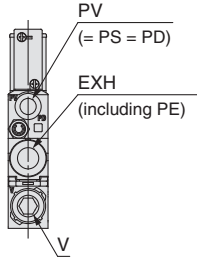

System	Ejector	
Body type	Single unit	
Exhaust type	Port exhaust	
Application and purpose	Vacuum pressure	—
	Exhaust	After piping, individual exhaust is necessary.
	Release pressure	Same pressure as PV

Port combination: PV = PS = PD

Circuit example

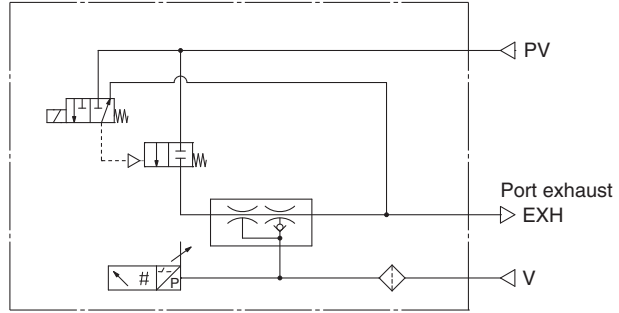

Supply valve: N.C. Release valve: Without release valve (J type)

Port layout No. **5**

Single unit: ZK2C□□□□□□□□□□
Manifold: ZK2□□□-A1□

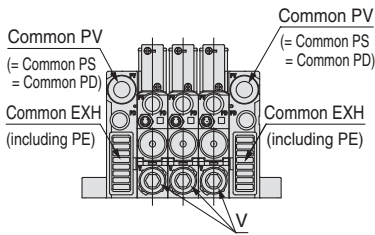

System	Ejector	
Body type	Manifold	
Exhaust type	Silencer common exhaust	
Application and purpose	Vacuum pressure	Common for each station
	Exhaust	Released in operating environment
	Release pressure	Same pressure as common PV

Port combination: Common PV = Common PS = Common PD

Circuit example

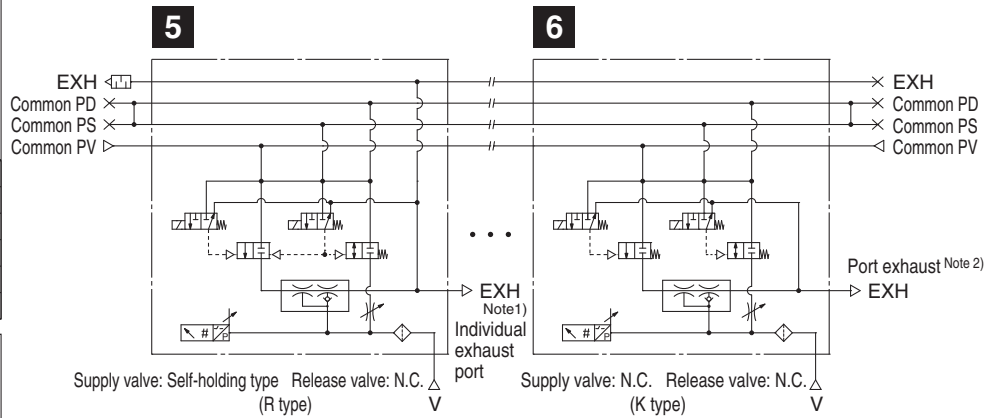

Supply valve: Self-holding type Release valve: N.C. (R type) Supply valve: N.C. Release valve: N.C. (K type)

Note 1) For silencer common exhaust type, individual exhaust port is provided to each station.
Note 2) Silencer common exhaust and individual port exhaust cannot be mixed in the same manifold.

Port layout No. **6**

Single unit: ZK2F□□□□□□□□□□
Manifold: ZK2□□□-A2□

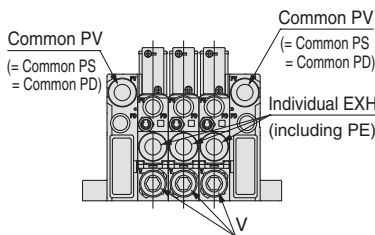

System	Ejector	
Body type	Manifold	
Exhaust type	Individual port exhaust	
Application and purpose	Vacuum pressure	Common for each station
	Exhaust	After piping, individual exhaust is necessary.
	Release pressure	Same pressure as common PV

Port Layout

System depends on vacuum source (vacuum pump/vacuum ejector).

Option -D

Port layout No. **7**

Single unit: ZK2P00□□□□-□-**D**

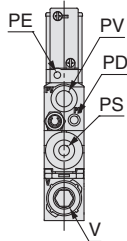

System	Vacuum pump	
Body type	Single unit	
Exhaust type	Without silencer	
Application and purpose	Vacuum pressure	—
	Exhaust	—
	Release pressure	PD pressure has to be supplied with PS pressure

Port combination: PV ≠ PS ≠ PD

Circuit example

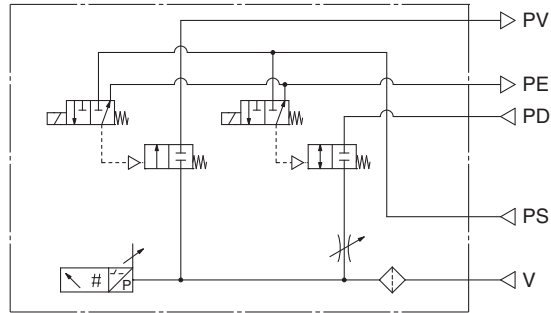

Supply valve: N.C. Release valve: N.C. (K type)

Port layout No. **8**

Single unit: ZK2Q00□□□□-□
Manifold: ZK2□□-P2□-**D**

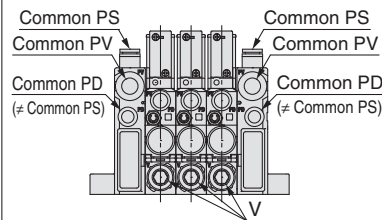

System	Vacuum pump	
Body type	Manifold	
Exhaust type	Without silencer	
Application and purpose	Vacuum pressure	Common for each station
	Exhaust	—
	Release pressure	Common PD pressure has to be supplied with common PS.

Port combination: Common PV ≠ Common PS ≠ Common PD

Circuit example

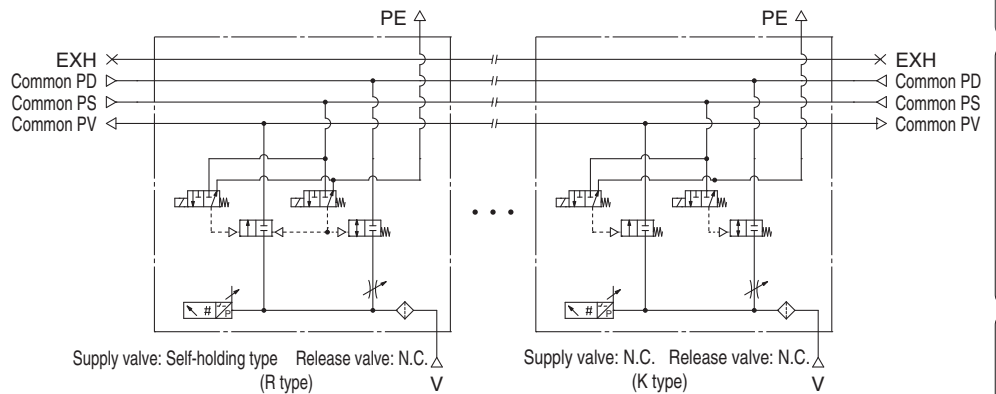

Supply valve: Self-holding type Release valve: N.C. (R type)

Supply valve: N.C. Release valve: N.C. (K type)

Port layout No. **9**

Single unit: ZK2A□□□□□□-□-**D**

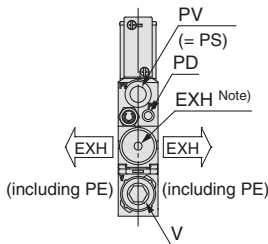

System	Ejector	
Body type	Single unit	
Exhaust type	Silencer exhaust	
Application and purpose	Vacuum pressure	—
	Exhaust	Released in operating environment
	Release pressure	PD pressure has to be supplied with PV pressure

Port combination: PV = PS ≠ PD

Circuit example

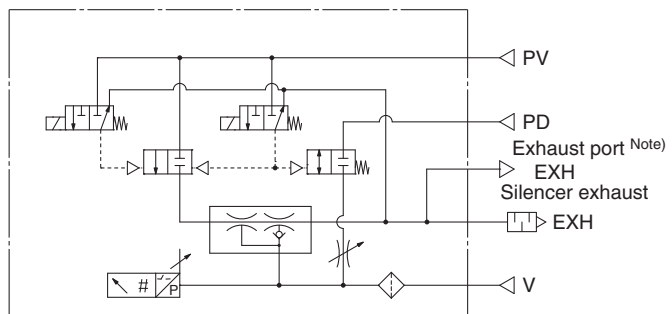

Supply valve: Self-holding type Release valve: N.C. (R type)

Note) Nozzle size: 12, 15

Refer to page 14 for the purpose of port and the operating pressure range.

Series ZK2

Port Layout

System depends on vacuum source (vacuum pump/vacuum ejector).

Option -D

Port layout No. 10

Single unit: ZK2B□□□□□□-□-D

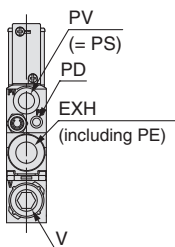

System	Ejector	
Body type	Single unit	
Exhaust type	Port exhaust	
Application and purpose	Vacuum pressure	—
	Exhaust	After piping, individual exhaust is necessary.
	Release pressure	PD pressure has to be supplied with PV pressure

Port combination: PV = PS ≠ PD

Circuit example

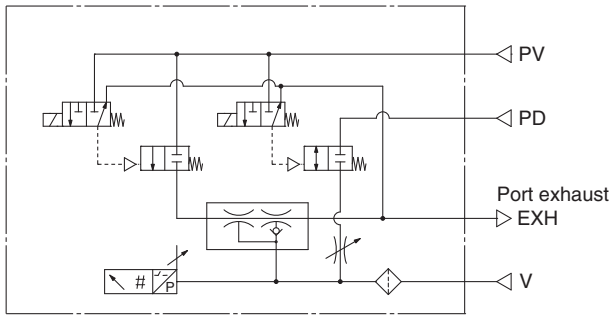

Supply valve: N.C. Release valve: N.C. (K type)

Port layout No. 11

Single unit: ZK2C□□□□□□-□
Manifold: ZZK2□□-A1□-D

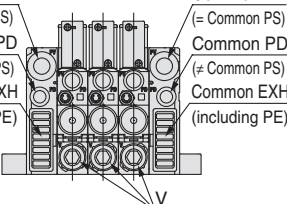

System	Ejector	
Body type	Manifold	
Exhaust type	Silencer common exhaust	
Application and purpose	Vacuum pressure	Common for each station
	Exhaust	Released in operating environment
	Release pressure	Common PD pressure has to be supplied with common PV.

Port combination: Common PV = Common PS ≠ Common PD

Circuit example

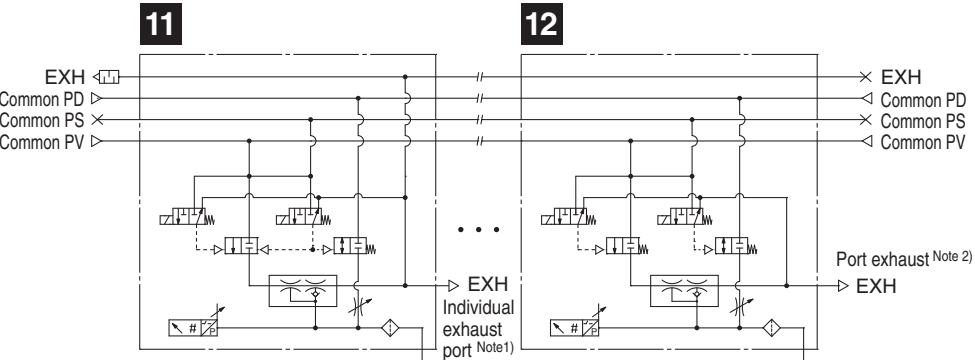

Supply valve: Self-holding type (R type) Release valve: N.C. (K type)

Supply valve: N.C. Release valve: N.C. (K type)

Port exhaust Note 2)

Port layout No. 12

Single unit: ZK2F□□□□□□-□
Manifold: ZZK2□□-A2□-D

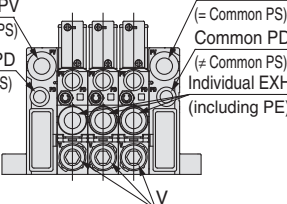

System	Ejector	
Body type	Manifold	
Exhaust type	Individual port exhaust	
Application and purpose	Vacuum pressure	Common for each station
	Exhaust	After piping, individual exhaust is necessary.
	Release pressure	Common PD pressure has to be supplied with common PV.

Note 1) For silencer common exhaust type, individual exhaust port is provided to each station.
 Note 2) Silencer common exhaust and individual port exhaust cannot be mixed in the same manifold.

Port Layout

System depends on vacuum source (vacuum pump/vacuum ejector).

Option -L

Port layout No. **13**

Single unit: ZK2C□□□□□□□□-□-L
Manifold: ZK2□□-A1□-L

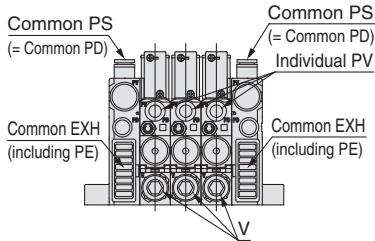

System	Ejector	
Body type	Manifold	
Exhaust type	Silencer common exhaust	
Application and purpose	Vacuum pressure	PV pressure can be changed per station.
	Exhaust	Released in operating environment
	Release pressure	Same pressure for common PS and common PD

Port layout No. **14**

Single unit: ZK2F□□□□□□□□-□-L
Manifold: ZK2□□-A2□-L

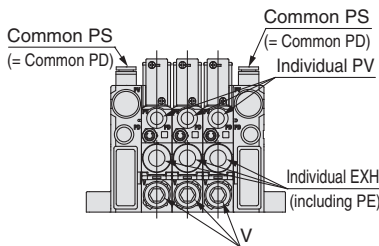

System	Ejector	
Body type	Manifold	
Exhaust type	Individual port exhaust	
Application and purpose	Vacuum pressure	PV pressure can be changed per station.
	Exhaust	After piping, individual exhaust is necessary.
	Release pressure	Same pressure for common PS and common PD

Port combination: Individual PV ≠ Common PS = Common PD

Circuit example

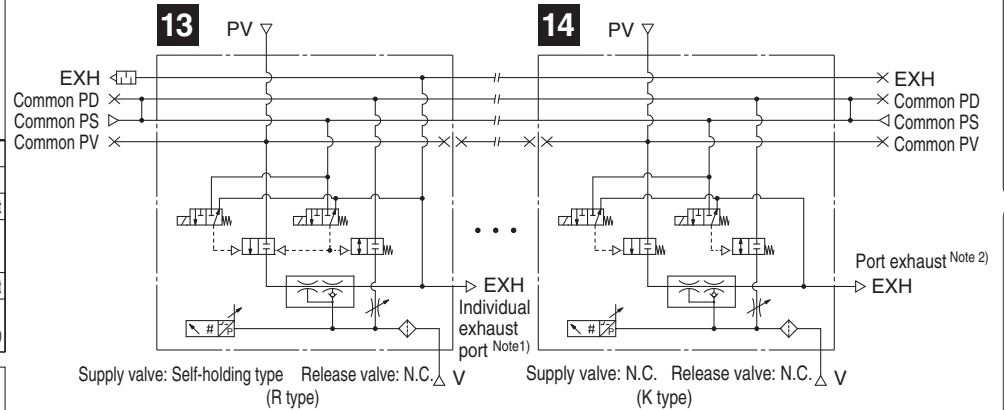

Note 1) For silencer common exhaust type, individual exhaust port is provided to each station.
Note 2) Silencer common exhaust and individual port exhaust cannot be mixed in the same manifold.

Application and Operating Pressure Range of Each Port

Port	Description	Vacuum Ejector System	Vacuum Pump System
PV	Air pressure supply port (Operating pressure range)	Compressed air supply for operating ejector 0.3 to 0.6 MPa*1)	—
	Vacuum pressure supply port (Operating pressure range)	—	Vacuum source (Vacuum pump) 0 to -101 kPa
PS	Pilot pressure supply port (Operating pressure range)	—	Compressed air supply for pilot valve 0.3 to 0.6 MPa
PD	Individual release pressure supply port (Operating pressure range)	Release pressure Compressed air supply for individual setting (Option) 0 to 0.6 MPa (PD ≤ PV)	0 to 0.6 MPa (PD ≤ PS)
V	Vacuum port	For connecting adsorption equipment including pad	
EXH	Exhaust port	Exhaust when ejector operates*2)	—
PE	Pilot pressure exhaust port	Exhaust when valve operates*3)	

*1) For without valve, pressure can be 0.3 MPa or less.
*2) For ejectors with silencer air exhausts from side A (slit on both sides). For port exhaust type air exhausts from side B.
*3) Pilot pressure of ejector is exhausted from ejector and common exhaust. Pump system exhausts air from PE port of the pump system. (Female thread type can be selected by option (-C) for PE port of pump system.)

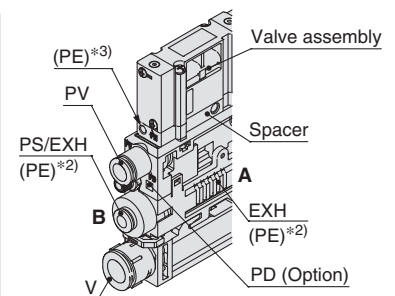

How to Order

Specifications/
Flow-rate Characteristics

Port Layout

Construction

Exploded View of Manifold

Dimensions

Specific Product Precautions

Series ZK2

Construction

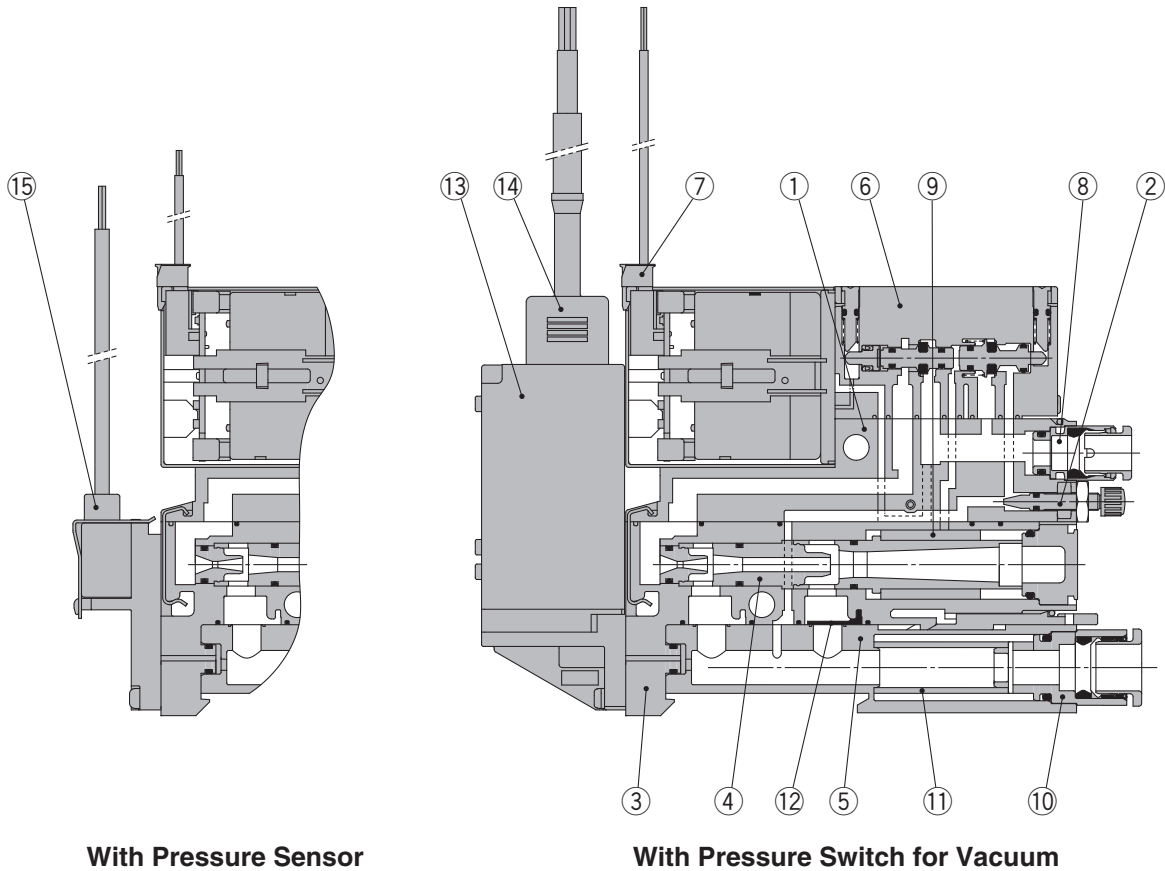

Component Parts

No.	Description	Material	Note
1	Valve body assembly	Resin	HNBR, NBR and steel are also used.
2	Needle assembly	Brass	Electroless nickel plated brass, resin, steel and NBR are used.
3	Ejector body assembly	Resin	HNBR, NBR and steel are also used.
4	Ejector assembly	Resin	NBR is also used.
5	Filter case assembly	Resin	Case body: Polycarbonate (Refer to Specific Product Precautions on page 29.)

Replacement Parts

No.	Description	Note
6	Valve assembly	
7	Connector assembly	Solenoid valve connector 3 wire (For double), 2 wire (For single)
8	One-touch fitting assembly	Supply (PV) port standard: $\phi 6$, 1/4"
9	Sound absorbing material	10 pcs. per 1 set
10	Vacuum port adapter assembly	With one-touch fitting and filter element (Case material: Polycarbonate)
11	Filter element	Nominal filtration rating: 30 μm , 10 pcs. per set
12	Check valve	For replacement or addition of manifold exhaust interference prevention (10 pcs. per set)
13	Vacuum pressure switch assembly	With 2 screws and 1 gasket
14	Lead wire with connector	
15	Pressure sensor assembly	With 2 screws and 1 gasket

Replacement Parts/How to Order

⑥ Valve assembly



① Applicable system

A	For ejector system
P	For vacuum pump system

② Valve type

K	Supply valve N.C., Release valve N.C.
R	Supply valve, self-holding type (Linked to release valve)
J	Supply valve only (Single)

③ Rated voltage

5	24 VDC
6	12 VDC

④ Lead wire entry direction

C	For plug-in (Manifold common wiring)
L	L-type plug connector with lead wire (Individual wiring)
LO	L-type plug connector, without connector

Select the ZK2-VA□□□□-A for energy saving switch.
This assembly does not include special cable assembly for energy saving switch.

⑦ Connector assembly



Applicable valve type

W	Valve type K/R (With supply valve and release valve)
S	Valve type J (Supply valve only)

Lead wire length

Nil	300 mm
6	600 mm
10	1000 mm
20	2000 mm
30	3000 mm

For single

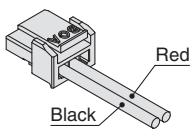

For double

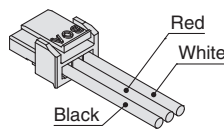

⑧ One-touch fitting assembly

(Purchasing order is available in units of 10 pieces.)



Port size

04	ø4 One-touch fitting (Straight)	Metric size
06	ø6 One-touch fitting (Straight)	
03	ø5/32" One-touch fitting (Straight)	Inch size
07	ø1/4" One-touch fitting (Straight)	

⑨ Sound absorbing material (10 pcs. per set)



Sound absorbing material holes diameter

1	300 μm
----------	--------

⑩ Vacuum port adapter assembly



One-touch fitting size

6	ø6 One-touch fitting	Metric size
8	ø8 One-touch fitting	
7	ø1/4" One-touch fitting	Inch size
9	ø5/16" One-touch fitting	

⑪ Filter element (10 pcs. per set)



Nominal filtration rating

3	30 μm
----------	-------

⑫ Check valve ^{Note)} (10 pcs. per set)



Note) When mounting a check valve additionally, the workpiece cannot be removed until vacuum is released.

⑬ Pressure switch for vacuum assembly



① Rated pressure range and function

E	0 to -101 kPa	Pressure switch for vacuum
F	-100 to 100 kPa	
V	100 to -100 kPa	

② Output specifications

A	NPN open collector 2 outputs
B	PNP open collector 2 outputs

③ Unit specifications

Nil	Unit selection function ^{Note 1)}
M	SI unit only ^{Note 2)}

Note 1) Unit selection function is not available in Japan due to measurement law.

Note 2) Fixed unit: kPa

④ Lead wire with connector

Nil	None	
G	With lead wire	When ① is E or F... For pressure switch for vacuum, Lead wire with connector (Length 2 m)
		When ① is V... For switch with energy saving function, Lead wire with connector (Length 2 m)

⑤ Mounting ^{Note)}

Nil	Mounted to the single unit
L	Mounted to the manifold

The length of the screw mounted to the ejector is different.
Note) When ordering ejector without valve, select Nil for mounting.

⑭ Lead wire with connector for pressure switch for vacuum (When individual lead wire is necessary, order with the port number below.)

• Lead wire with connector for pressure switch for vacuum
ZS - 39 - 5G

• Lead wire with connector for switch with energy saving function



Output specifications

A	NPN open collector
B	PNP open collector

⑮ Pressure sensor assembly



Rated pressure range and specifications

1	0 to -101 kPa, Output: 1 to 5 V, Accuracy: ±2% F.S. or less
3	-100 to 100 kPa, Output: 1 to 5 V, Accuracy: ±2% F.S. or less

Mounting

Nil	Mounted to the single unit
L	Mounted to the manifold

The screw length mounted to the ejector is different.

How to Order

Specifications/
Flow-rate Characteristics

Port Layout

Construction

Exploded View of Manifold

Dimensions

Specific Product Precautions

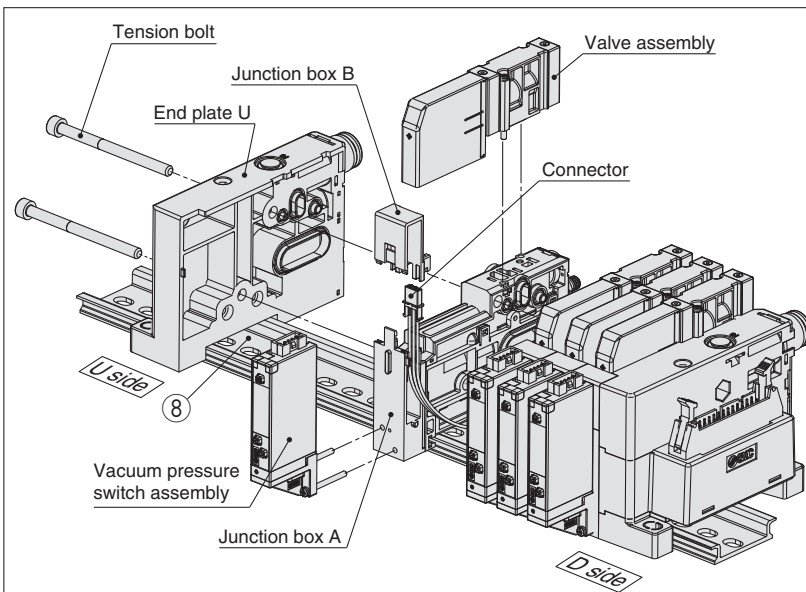

How to increase manifold stations

[To increase the number of stations from odd number (1, 3, 5, 7, 9) in common wiring type to even number (2, 4, 6, 8, 10)]
(Common wiring of odd number station has a vacant connector for one station. Easy to add a station.)

- 1) Remove the tension bolt.
- 2) Remove the end plate U.
- 3) Remove the valve assembly of a single unit for extra station(s) for manifold.
- 4) Remove the switch assembly if it is present. (Be careful not to drop the gasket. Refer to **Fig.1**)
- 5) Remove the junction box B (top) using a precision screwdriver. (Refer to **Fig.2**)
- 6) Mount the extra connector to the junction box B. (Refer to **Fig.3**) (Engage the recess of the connector and the protrusion of the junction box B, referring to **Fig.3-A**)
- 7) Mount a single unit for extra station(s) for manifold to the end surface of U side. (Do not let the gasket or lead wire get caught.)
- 8) Mount the end plate U with the appropriate length of tension bolts for the number of stations required. (Tightening torque: 0.75 N·m.)
- 9) Mount the junction box B to the junction box A.
- 10) Assemble the valve assembly. (Tightening torque: 0.15 N·m)

[To increase the number of stations from even number to odd number, or increase two stations or more]

- 1) Remove the valve assembly for all stations. (Single unit for extra station is also removed.)
- 2) Remove the switch assembly if it is present. (Be careful not to drop the gasket. Refer to **Fig.1**)
- 3) Remove the junction box B (top) for all stations using a precision screwdriver. (Refer to **Fig.2**) (Remove the junction box B from D side.)
- 4) Remove all connectors mounted to the junction box B. (Be careful not to break the connector clip.)
- 5) Remove the tension bolt.
- 6) Remove the end plate D assembly.
- 7) Remove the connector housing assembly from the end plate D assembly. (Refer to **Fig.4**)
- 8) Mount the connector housing assembly for extra station(s) to the end plate D assembly. (Refer to **Fig.4**) (Insert two clips of the housing mounting surface to the square holes of the end plate, and slide the connector housing assembly.)
- 9) Remove the end plate U. (Be careful not to drop the gasket.)
- 10) Mount a single unit for extra station(s) for manifold to the end surface of U side. Do not let the gasket caught.
- 11) Mount the end plate U and D with the appropriate length of tension bolts for the number of stations required. (Tightening torque: 0.75 N·m.)
- 12) Mount the connector for all stations to the junction box B. (Refer to **Fig.3**) (Engage the recess of the connector and the protrusion of the junction box B. (Refer to **Fig.3-A**))
- 13) Mount the junction box A to the junction box B. Push the wires down the side and mount the junction box A to the junction box B following a decreasing mark tube numbers from U side. (Do not let the lead wire get caught.)
- 14) Assemble the valve assembly. (Tightening torque: 0.15 N·m)

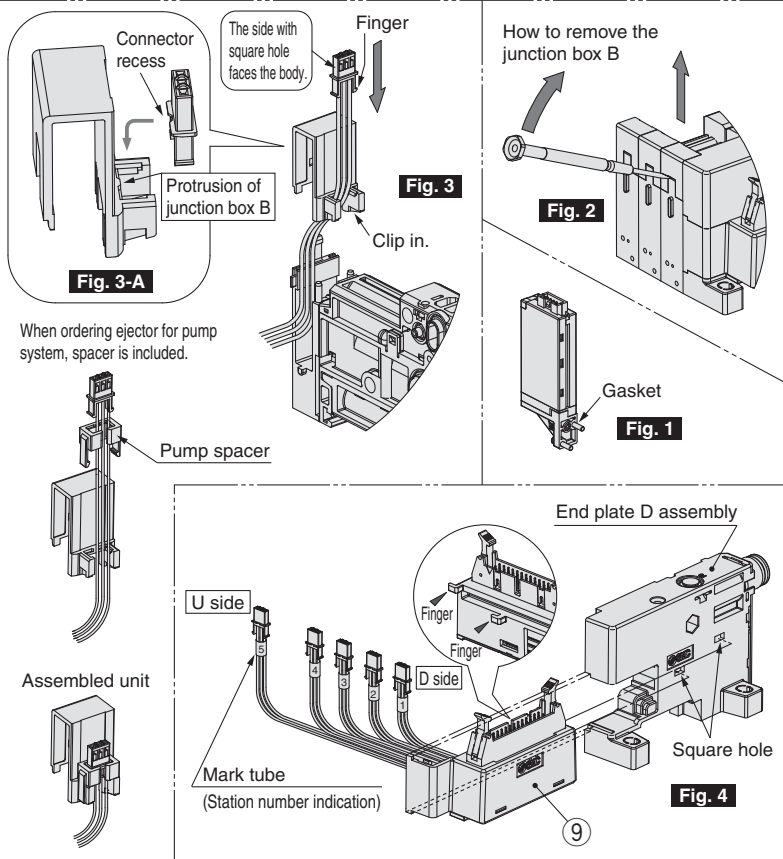

9 Connector housing assembly

ZK2 - CH **2** **04** - A

Applicable stations

02	For 2 stations manifold
04	For 4 stations manifold
06	For 6 stations manifold
08	For 8 stations manifold
10	For 10 stations manifold

Connector type

1	D sub-connector (25 pins)
2	Flat ribbon cable (26 pins)

Plug (For one-touch fitting) (Purchasing order is available in units of 10 pieces.)

Mounted onto ports which are not used (PV, PS, PD, etc.)

KQ2P - **06**

Model and dimensions

Symbol	Applicable size ød	A	L	øD	Weight (g)	Note
06	ø6	18	35	8	1	White
08	ø8	20.5	39	10	2	White
07	ø1/4"	18	35	8.5	1	Orange
09	ø5/16"	20.5	39	10	2	Orange

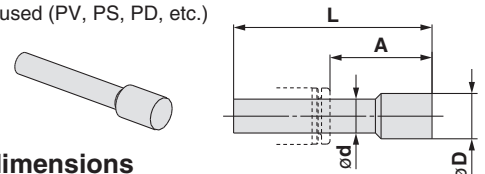

Series ZK2

Dimensions: Single Unit

ZK2_B^A□_R□NL2-□

Ejector system, Single unit, With supply valve/release valve, Without pressure sensor/switch

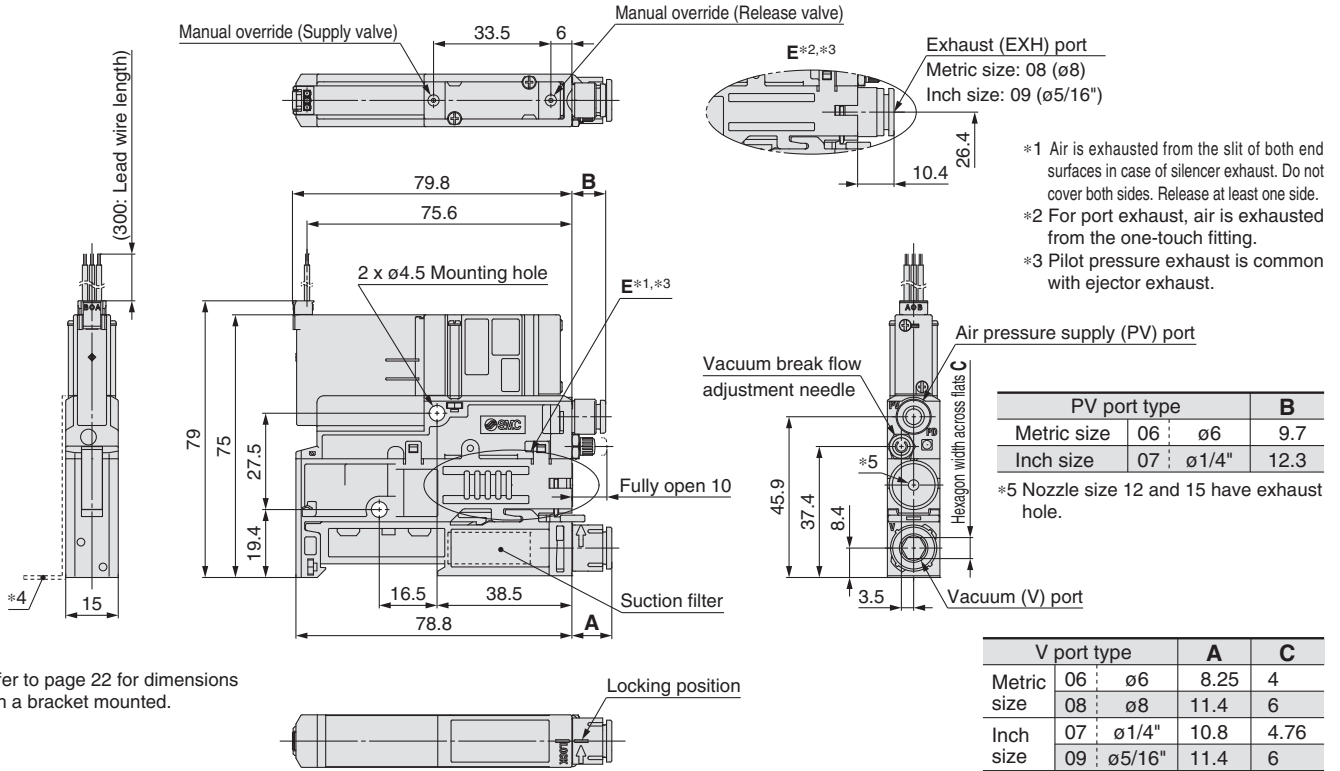

*4 Refer to page 22 for dimensions with a bracket mounted.

ZK2P00_R^K□NL2-□

Vacuum pump system, Single unit, With supply valve/release valve, Without pressure sensor/switch

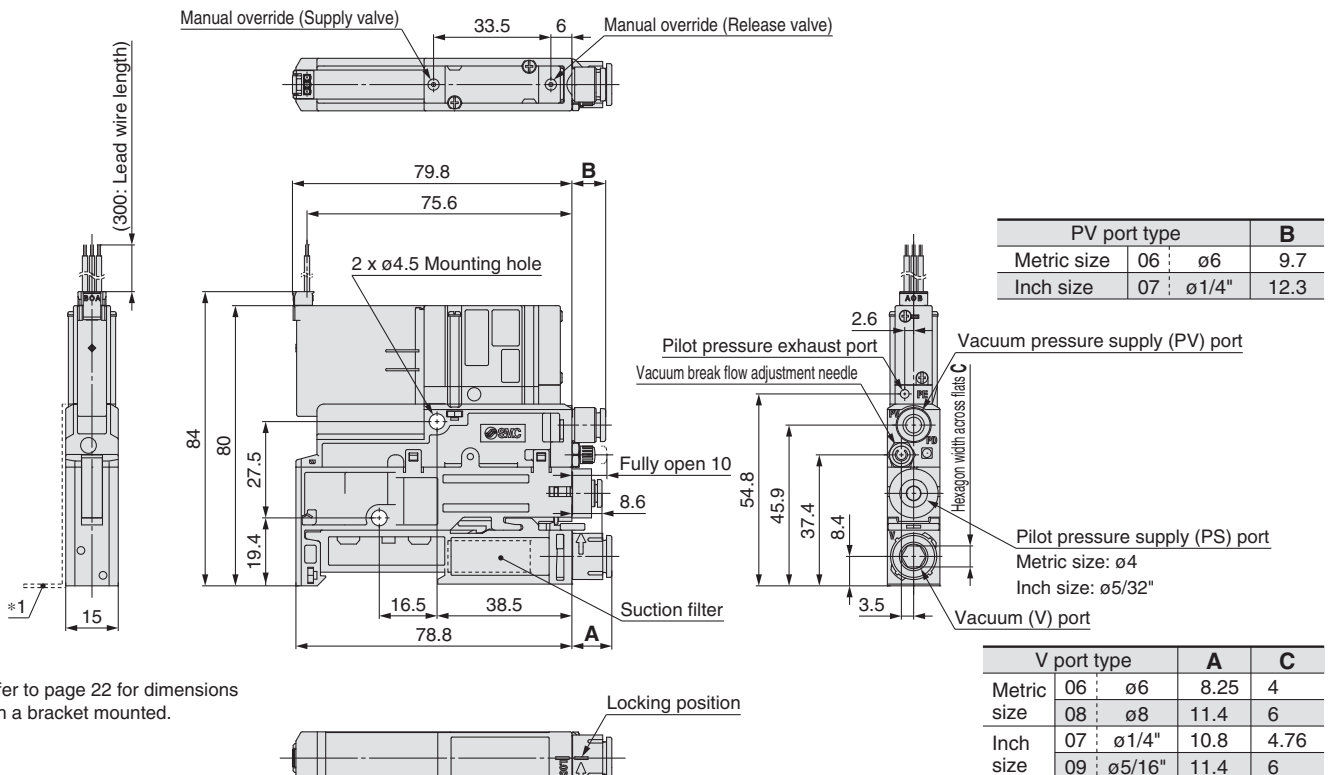

*1 Refer to page 22 for dimensions with a bracket mounted.

Dimensions: Single Unit

ZK2^A_B□J□NL2-□

Ejector system, Single unit, With supply valve, Without pressure sensor/switch

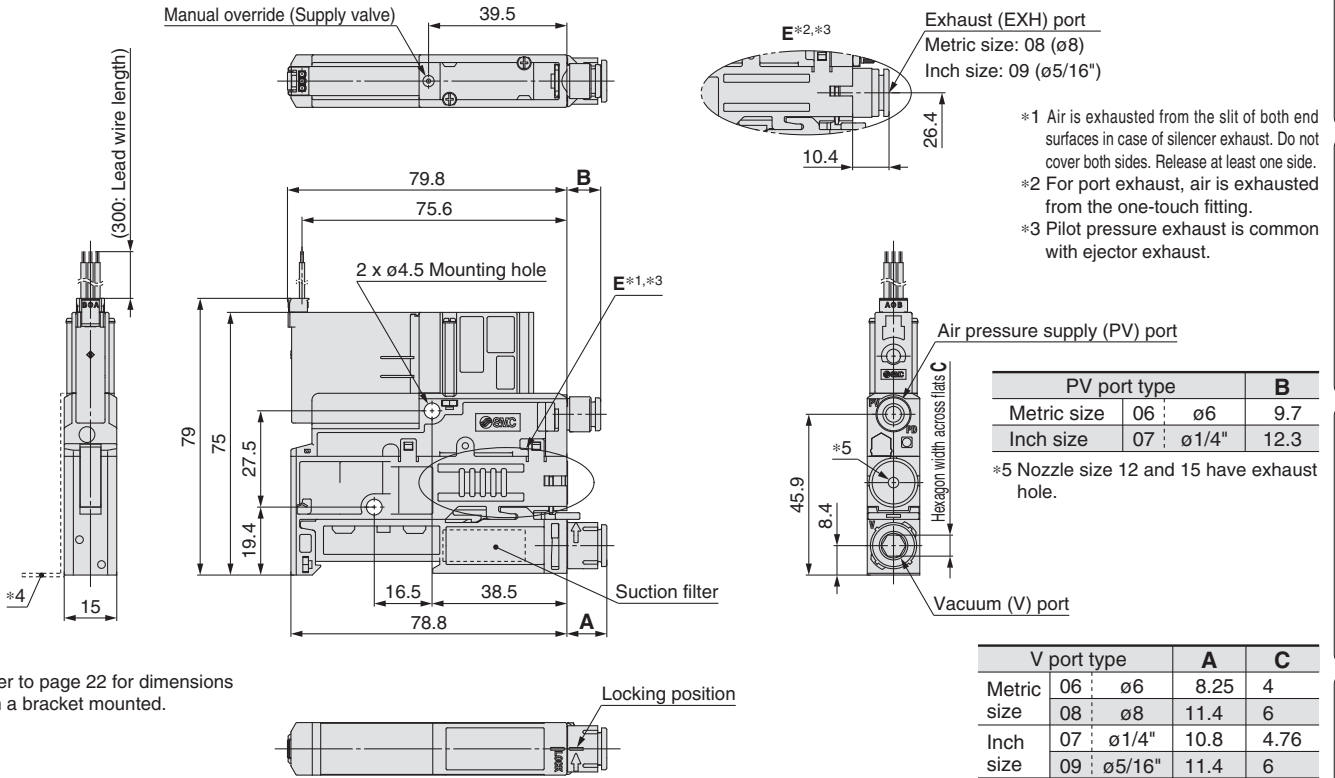

ZK2^A_B□N0NN-□

Ejector system, Single unit, Without valve, Without pressure sensor/switch

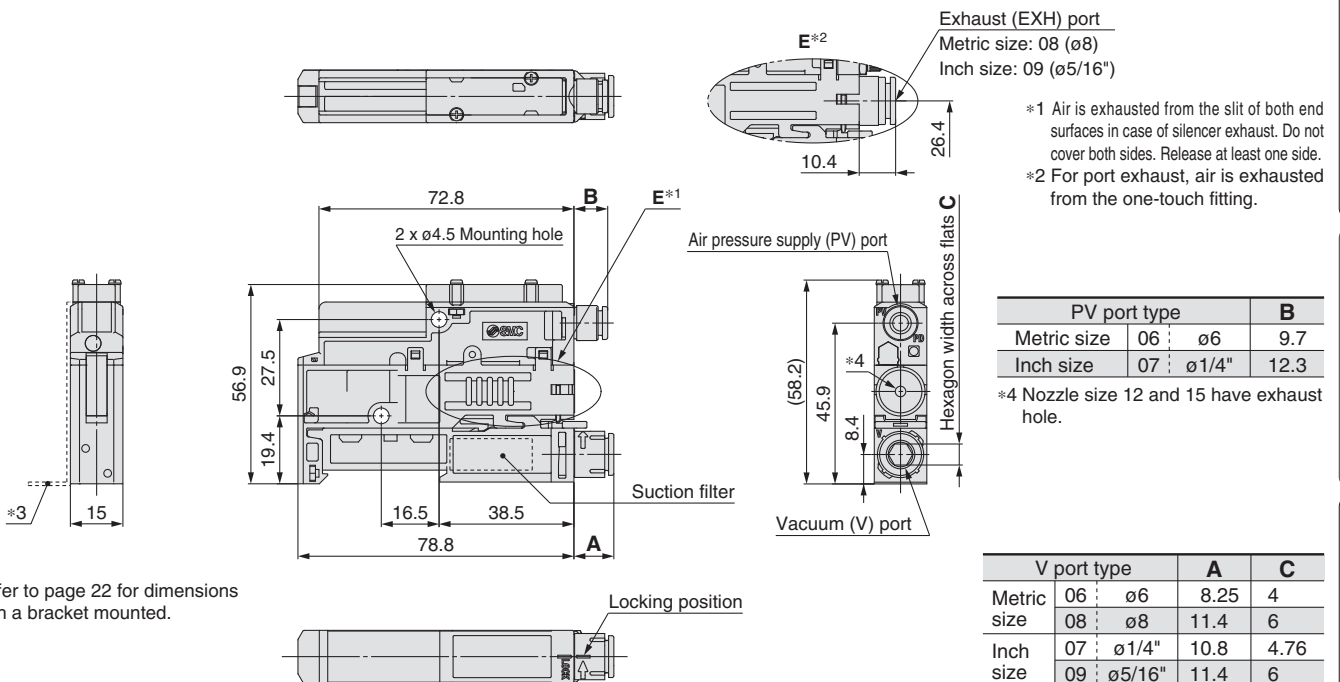

How to Order

Specifications/
Flow-rate Characteristics

Port Layout

Construction

Exploded View of Manifold

Dimensions

Specific Product Precautions

Series ZK2

Dimensions: Single Unit

ZK2_B□_R□_PL-□

Ejector system, Single unit,
With supply valve/release valve,
With pressure sensor

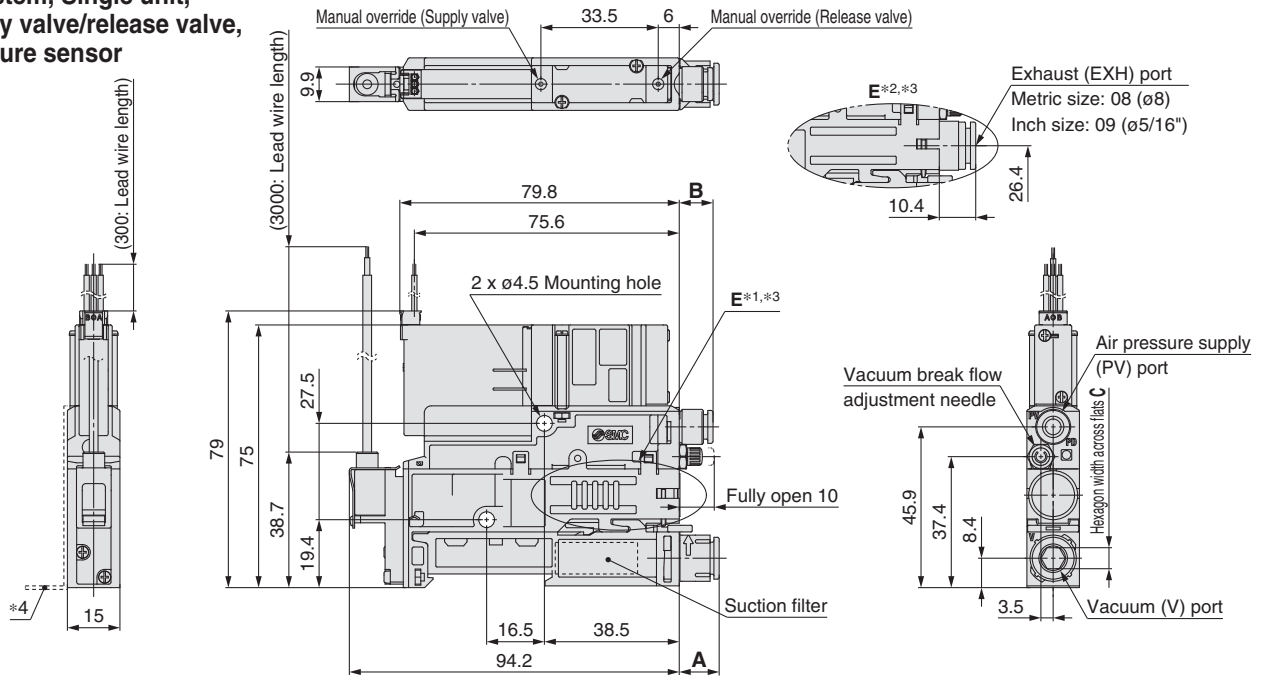

- *1 Air is exhausted from the slit of both end surfaces in case of silencer exhaust. Do not cover both sides. Release at least one side.
- *2 For port exhaust, air is exhausted from the one-touch fitting.
- *3 Pilot pressure exhaust is common with ejector exhaust.
- *4 Refer to page 22 for dimensions with a bracket mounted.

V port type			A	C
Metric size	06	ø6	8.25	4
	08	ø8	11.4	6
Inch size	07	ø1/4"	10.8	4.76
	09	ø5/16"	11.4	6

PV port type			B
Metric size	06	ø6	9.7
Inch size	07	ø1/4"	12.3

ZK2_B□_R□□L-□
A to J

Ejector system, Single unit,
With supply valve/release valve,
With pressure switch

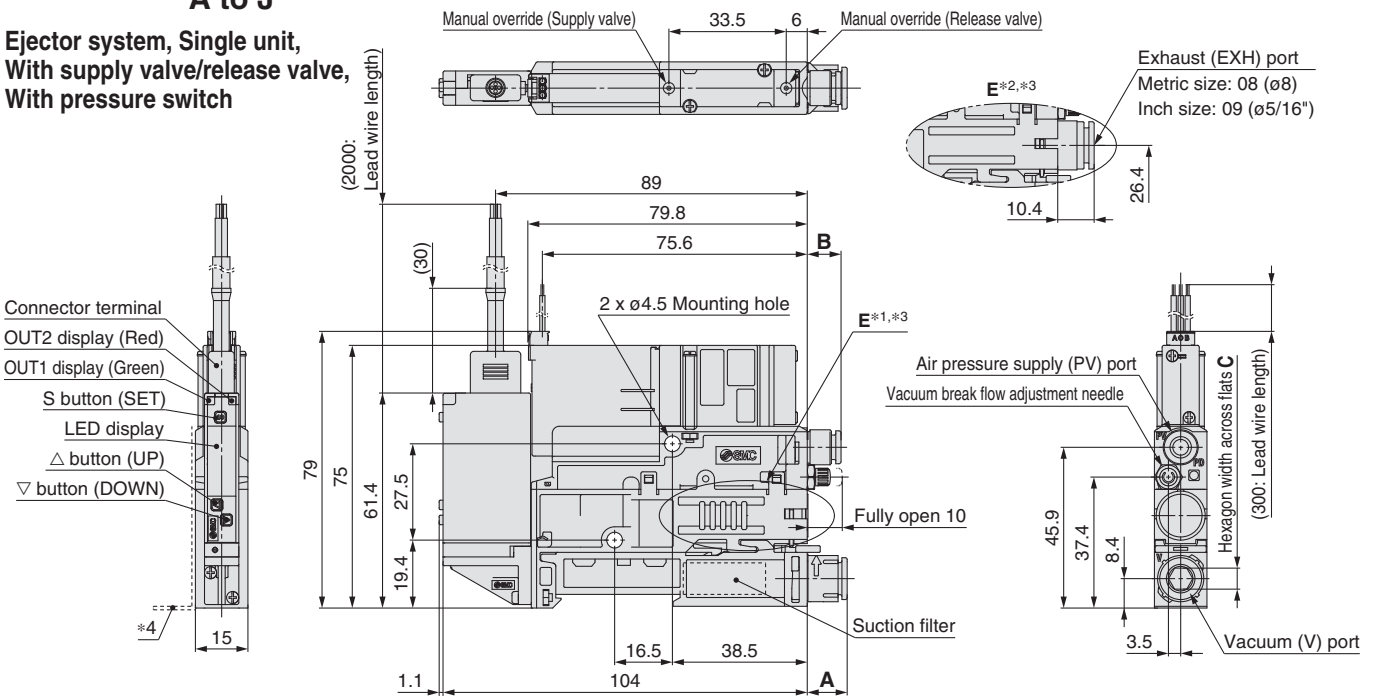

- *1 Air is exhausted from the slit of both end surfaces in case of silencer exhaust. Do not cover both sides. Release at least one side.
- *2 For port exhaust, air is exhausted from the one-touch fitting.
- *3 Pilot pressure exhaust is common with ejector exhaust.
- *4 Refer to page 22 for dimensions with a bracket mounted.

V port type			A	C
Metric size	06	ø6	8.25	4
	08	ø8	11.4	6
Inch size	07	ø1/4"	10.8	4.76
	09	ø5/16"	11.4	6

PV port type			B
Metric size	06	ø6	9.7
Inch size	07	ø1/4"	12.3

Dimensions: Single Unit

With bracket

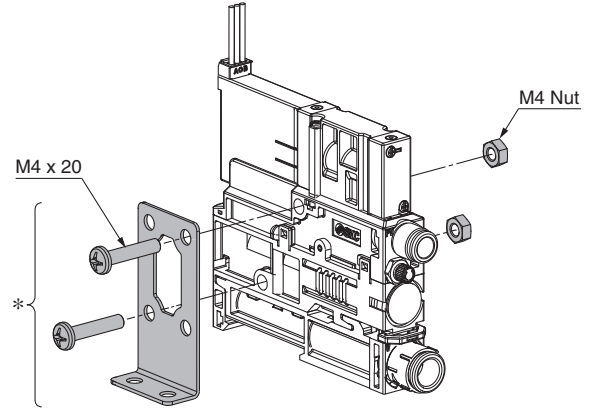
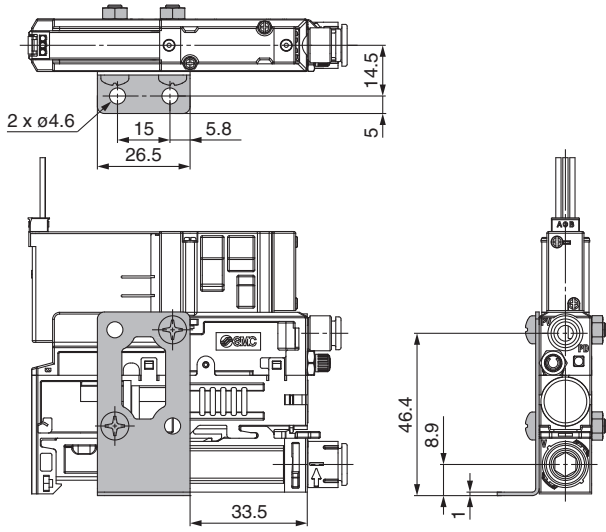

* Mounting bracket for single unit (Option), [Nuts and bolts are included.]
Part number: ZK2-BK1-A

How to Order

Specifications/
Flow-rate Characteristics

Port Layout

Construction

Exploded View of Manifold

Dimensions

Specific Product Precautions

Series ZK2

Dimensions: Manifold Individual Wiring

ZK2□-P_A□L

Ejector system, Vacuum pump system, Individual wiring manifold, With supply valve/release valve, Without pressure sensor/switch

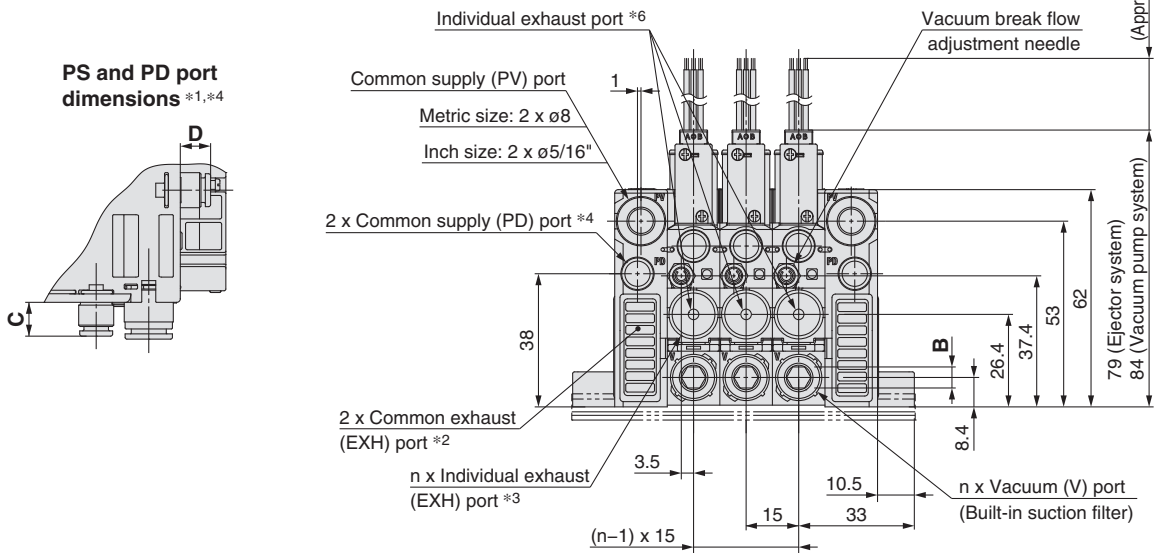
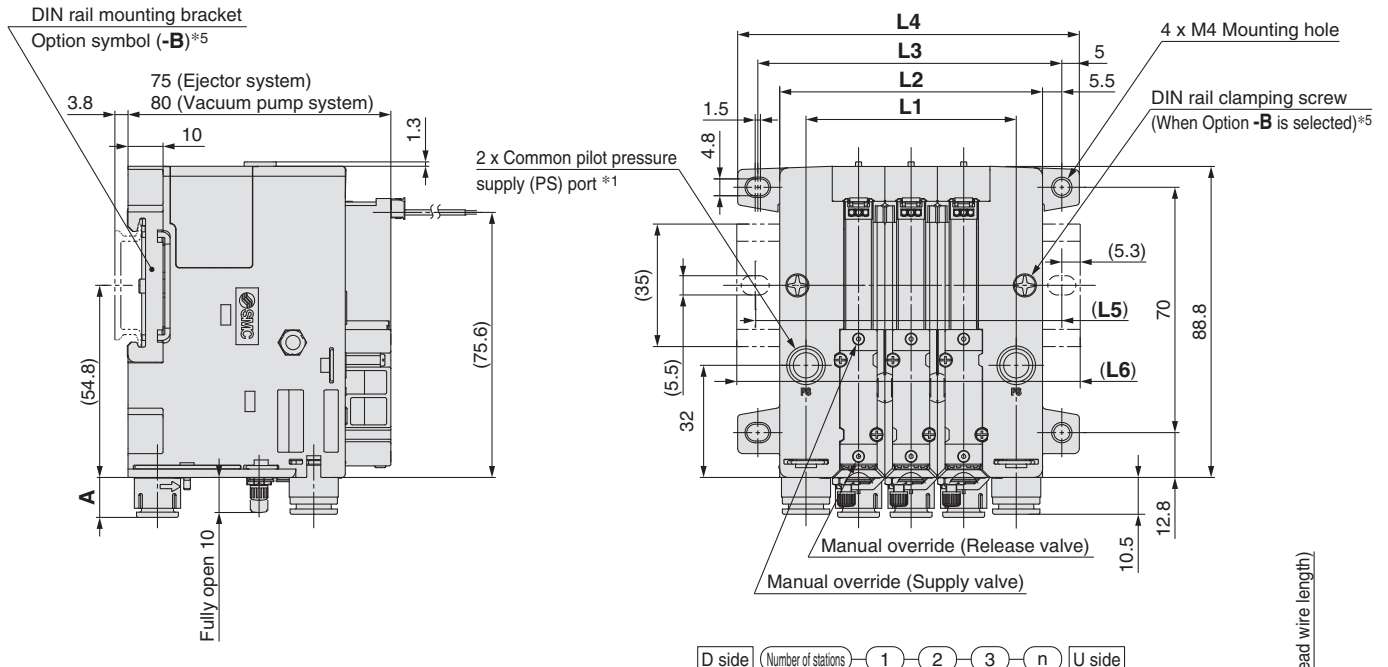

Port type	A	Hexagon width across flats B	C	D
Metric size	06	8.3	4	9.7
	08	11.4	6	—
Inch size	07	10.8	4.76	12.3
	09	11.4	6	—

Number of stations	(mm)									
	1	2	3	4	5	6	7	8	9	10
L1	30	45	60	75	90	105	120	135	150	165
L2	45	60	75	90	105	120	135	150	165	180
L3	56.8	71.8	86.8	101.8	116.8	131.8	146.8	161.8	176.8	191.8
L4	67.5	82.5	97.5	112.5	127.5	142.5	157.5	172.5	187.5	202.5
L5	62.5	75	87.5	112.5	125	137.5	150	162.5	187.5	200
L6	73	85.5	98	123	135.5	148	160.5	173	198	210.5

*1 Common pilot pressure supply port is only for vacuum pump system. (mm: ø6 inch: ø1/4")

*2 Pump system with individual exhaust port type does not have exhaust outlet.

*3 When individual exhaust port type is selected (Body type: F)

*4 Only when common PD port type option (Symbol: -D) is selected (mm: ø6 inch: ø1/4")

*5 Select an option of How to Order of manifold to fix the manifold to DIN rail.

*6 For silencer common exhaust type, air is also exhausted from individual exhaust port of each station. (Ejector system)

Dimensions: Manifold D-sub Connector

ZZK2□-P_A□F

Ejector system, Vacuum pump system, Common wiring manifold, With supply valve/release valve, With pressure sensor

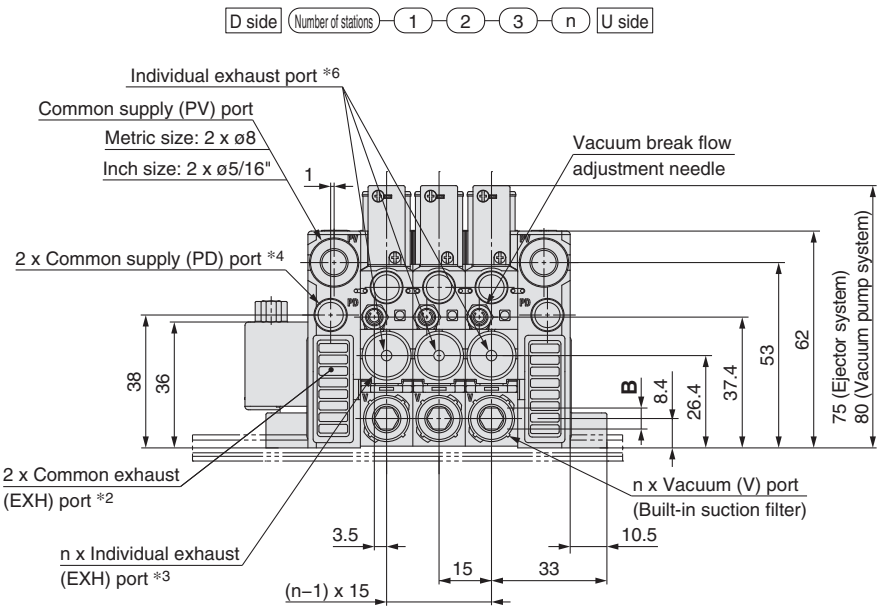
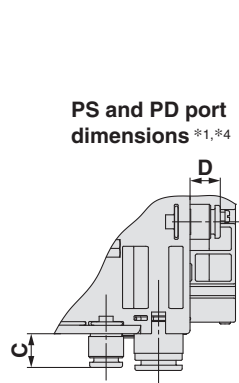
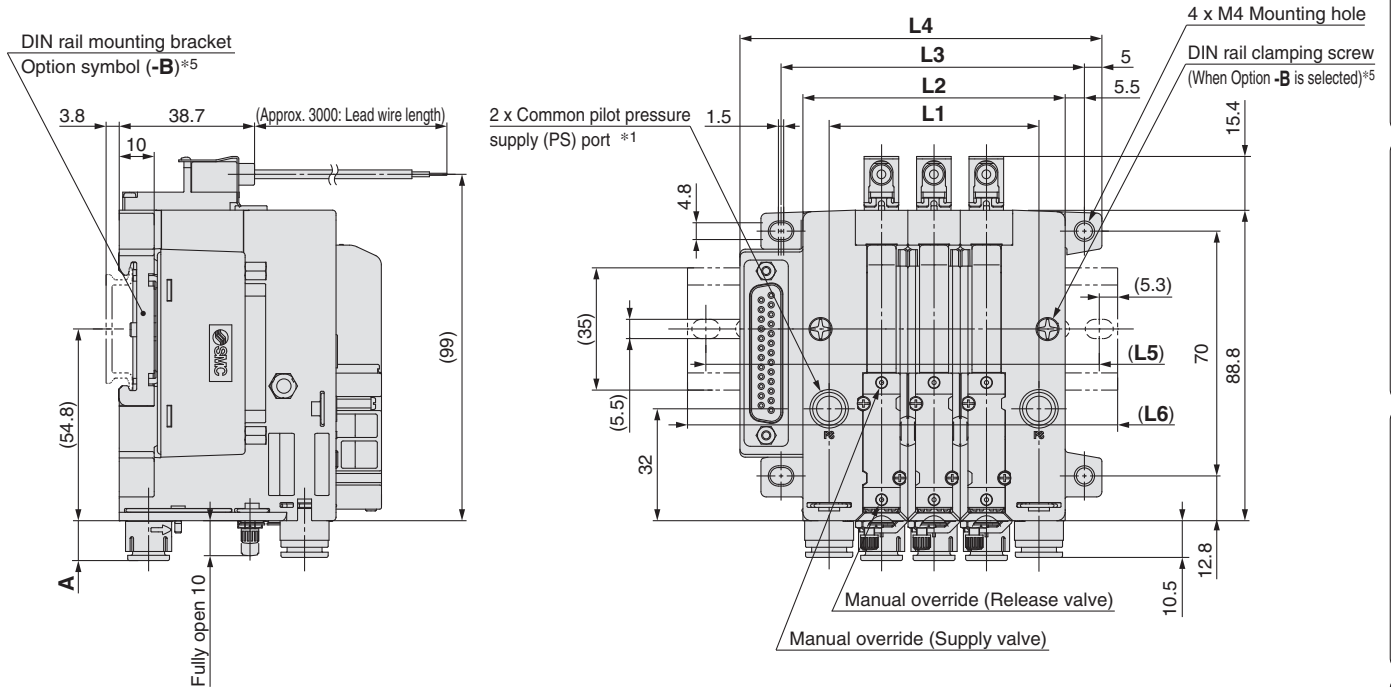

Port type	A	Hexagon width across flats B	C	D
Metric size 06	8.3	4	9.7	8.7
08	11.4	6	—	—
Inch size 07	10.8	4.76	12.3	11.3
09	11.4	6	—	—

Number of stations	(mm)									
	1	2	3	4	5	6	7	8	9	10
L1	30	45	60	75	90	105	120	135	150	165
L2	45	60	75	90	105	120	135	150	165	180
L3	56.8	71.8	86.8	101.8	116.8	131.8	146.8	161.8	176.8	191.8
L4	73.5	88.5	103.5	118.5	133.5	148.5	163.5	178.5	193.5	208.5
L5	75	100	112.5	125	137.5	150	175	187.5	200	212.5
L6	85.5	110.5	123	135.5	148	160.5	185.5	198	210.5	223

*1 Common pilot pressure supply port is only for vacuum pump system. (mm: ø6 inch: ø1/4")
 *2 Pump system with individual exhaust port type does not have exhaust outlet.
 *3 When individual exhaust port type is selected (Body type: F)
 *4 Only when common PD port type option (Symbol: -D) is selected (mm: ø6 inch: ø1/4")
 *5 Select an option of How to Order of manifold to fix the manifold to DIN rail.
 *6 For silencer common exhaust type, air is also exhausted from individual exhaust port of each station. (Ejector system)

How to Order
 Specifications/
 Flow-rate Characteristics
 Port Layout
 Construction
 Exploded View of Manifold
 Dimensions
 Specific Product Precautions

Series ZK2

Dimensions: Manifold Flat Ribbon Cable

ZZK2□-P_A□P

Ejector system, Common wiring manifold, With supply valve/release valve, With pressure switch

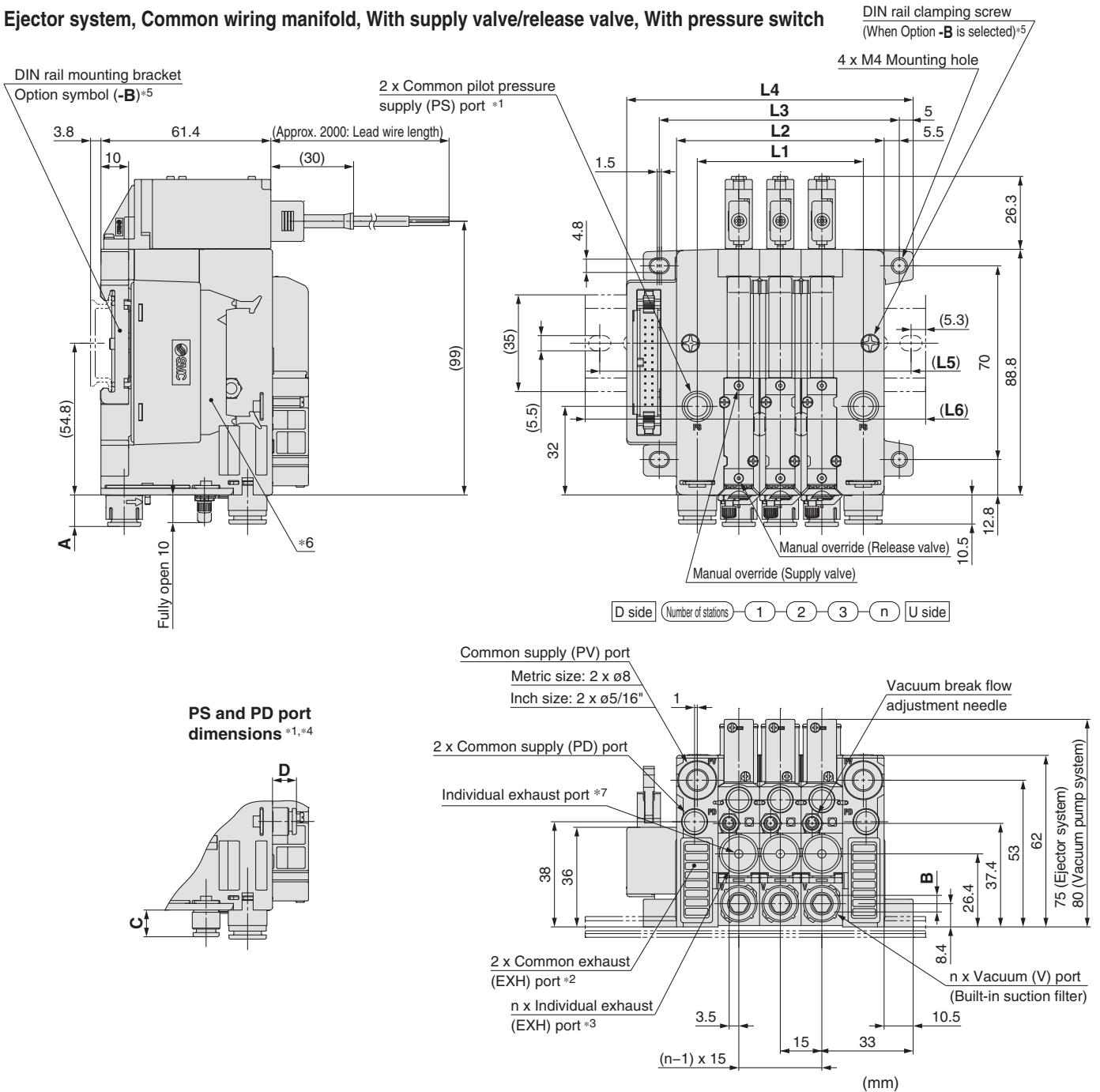

PS and PD port dimensions ^{*1,*4}

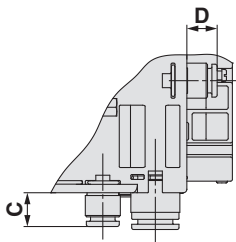

Port type	A	Hexagon width across flats B	C	D
Metric size	06	8.3	4	9.7
	08	11.4	6	—
Inch size	07	10.8	4.76	12.3
	09	11.4	6	—

Number of stations	(mm)									
	1	2	3	4	5	6	7	8	9	10
L1	30	45	60	75	90	105	120	135	150	165
L2	45	60	75	90	105	120	135	150	165	180
L3	56.8	71.8	86.8	101.8	116.8	131.8	146.8	161.8	176.8	191.8
L4	73.5	88.5	103.5	118.5	133.5	148.5	163.5	178.5	193.5	208.5
L5	75	100	112.5	125	137.5	150	175	187.5	200	212.5
L6	85.5	110.5	123	135.5	148	160.5	185.5	198	210.5	223

- *1 Common pilot pressure supply port is only for vacuum pump system. (mm: ø6 inch: ø1/4")
- *2 Pump system with individual exhaust port type does not have exhaust outlet.
- *3 When individual exhaust port type is selected (Body type: F)
- *4 Only when common PD port type option (Symbol: -D) is selected (mm: ø6 inch: ø1/4")
- *5 Select an option of How to Order of manifold to fix the manifold to DIN rail.
- *6 Applicable connector: Connector for flat ribbon cable (26P)(MIL-C-83503 compliant)
- *7 For silencer common exhaust type, air is also exhausted from individual exhaust port of each station. (Ejector system)

Electrical Wiring Specifications

D-sub Connector

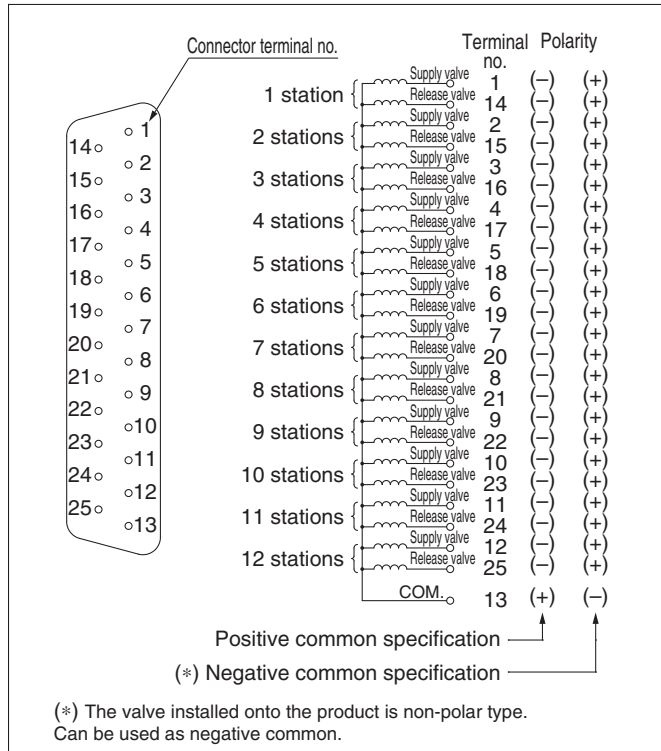

Flat Ribbon Cable Connector

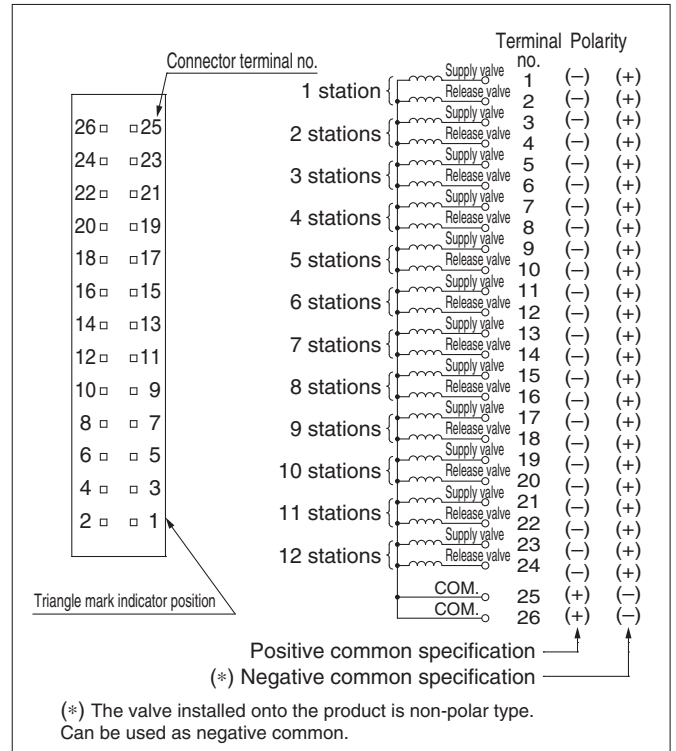

How to Order

Specifications/
Flow-rate Characteristics

Port Layout

Construction

Exploded View of Manifold

Dimensions

Specific Product Precautions



Series ZK2

Specific Product Precautions 1

Be sure to read the below before handling. Refer to back cover for Safety Instructions. For Vacuum Equipment Precautions, refer to "Handling Precautions for SMC Products"(M-E03-3) and Operation Manual. The Operation Manual can be downloaded from the SMC website, <http://www.smcworld.com>

Supply Valve/Release Valve

Warning

1. Manual override operation

- Manual override is non-locking push type. Push the manual override with a screwdriver of a diameter smaller than indicated in the diagram until it reaches the end.

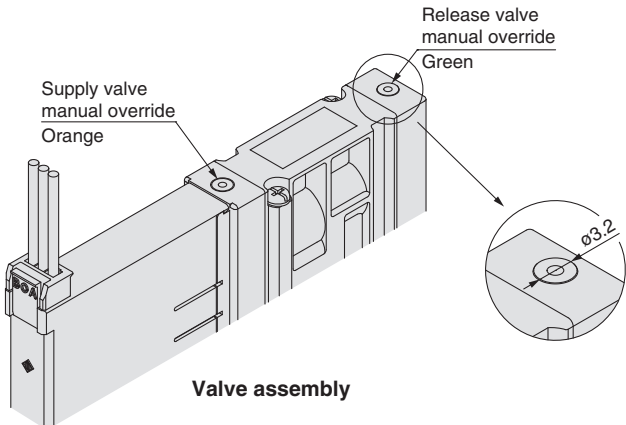

- Confirm that the product operates safely before the manual override is operated.

Note) When the linked type supply and release valves operation is selected, the supply valve can hold the position and will not switch off even if the supply valve manual override operation is finished unless the release valve manual override is pressed.

2. Self-holding function of supply valve

For valve assemblies where the supply and release valves are linked the supply valve is a self-holding type. Instantaneous energization (20 ms or more) of the supply valve allows the supply valve to hold. Continuous energization is not necessary. Energize the release valve to turn the supply valve off.

Note 1) Main valve in the valve assembly is made of elastic seal. Self-holding is performed by friction resistance of the seal. Do not apply impact resistance in the direction of the main valve shaft during the installation to moving parts. When the self-holding valve is applied with impact, energize it continuously, or use K type. (Refer to 3 Combination of Supply Valve and Release Valve on page 1.) (Vibration and impact should be 50 m/s² or less.)

Note 2) Self-holding type valve cannot use a digital switch for vacuum with energy saving function.

3. Default setting

When the valve assembly is delivered, the supply valve is on the OFF position, but it may be on the ON position due to the vibration or impact during transportation or device installation. Turn to the OFF position manually or by energizing before use.

Supply Valve/Release Valve

Warning

4. Wiring specifications and light/surge voltage suppressor

Wiring should be connected as shown below. Connect with the power supply respectively. (Solenoid valve is non-polar type.)

Single solenoid (Without release valve)

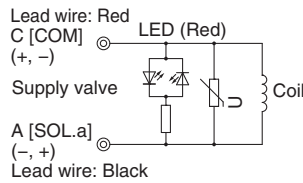

Double solenoid (With release valve)

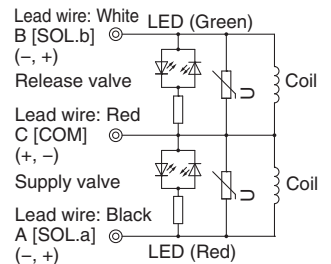

Light/surge voltage suppressor circuit is equipped for both single and double solenoid.

Red LED turns on when supply valve (SOL.a) is energized. Green LED turns on when release valve (SOL.b) is energized.

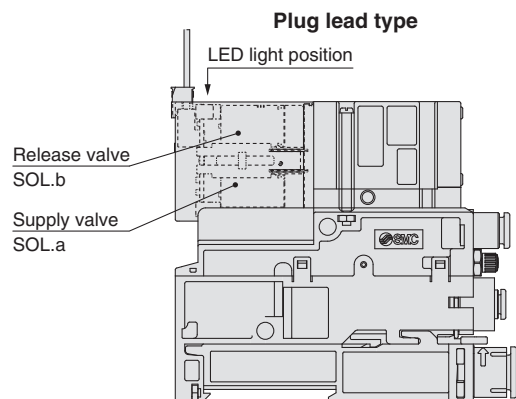
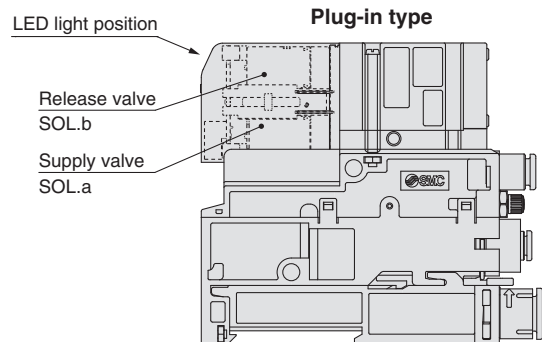

5. Continuous duty

If a supply valve/release valve is energized continuously for a long time, the rise in temperature due to heat-up of the coil may cause a decline in solenoid valve performance, reduce service life, or have adverse effects on peripheral equipment. When the energizing time per day is longer than non-energizing time, use self-holding linked type valve using instantaneous energizing.

Specific Product Precautions 2

Be sure to read the below before handling. Refer to back cover for Safety Instructions. For Vacuum Equipment Precautions, refer to "Handling Precautions for SMC Products"(M-E03-3) and Operation Manual. The Operation Manual can be downloaded from the SMC website, <http://www.smcworld.com>



Surge Voltage Intrusion

⚠ Caution

The surge voltage created when the power supply is cut off could apply to the de-energized load equipment through the output circuit. In cases where the energized load equipment has a larger capacity (power consumption) and is connected to the same power supply as the product, the surge voltage could malfunction and/or damage the internal circuit element of the product and the internal device of the output equipment. To avoid this situation, place a diode which can suppress the surge voltage between the COM lines of the load equipment and output equipment.

Plug Connector

⚠ Caution

1. Installation/Removal of connector

- To install the connector, hold the cover and insert the connector straight pushing the connector lever with your finger. Ensure that the connector lever clip is properly inserted onto mating part.
- To remove the connector, hold the cover and pull out the connector straight pushing the connector lever clip.

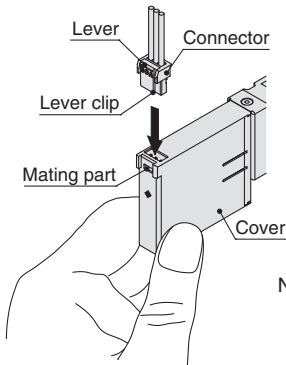

Note) Do not pull the lead wire with a force of 25 N or more, as this may damage the connector or cover.

2. Part number of connector assembly and lead wire length

The standard lead wire length for the connector assembly is 300 mm. For other lengths, refer to the table below.

ZK2-LVS□-A Connector assembly for single
(For with supply valve, no release valve)

ZK2-LVW□-A Connector assembly for double
(For with both supply valve and release valve)

For single

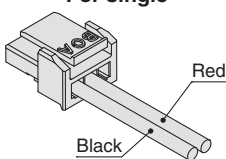

For double

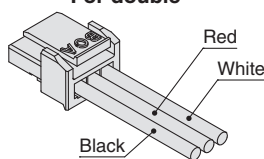

Nil	300 mm
6	600 mm
10	1000 mm
20	2000 mm
30	3000 mm

Note) When ordering, put the connector assembly part number to the product part number without connector.

Suction Filter

⚠ Caution

1. Replacement procedure for filter element

- To pull out the vacuum port adapter, rotate the adapter by about 90 degrees in direction A and pull in direction B. The adapter can be removed with the suction filter from the filter case.
- Remove the suction filter from the vacuum port adapter and replace it with a new suction filter.

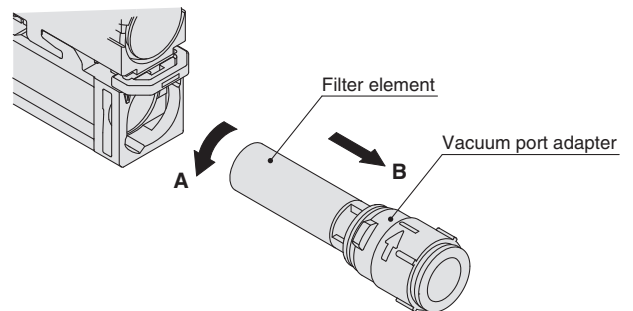

- When installing the filter, insert the filter to the end so that there is no gap or bending between the filter and the vacuum port adapter. The gap or bending will cause the element to deform inside the case.

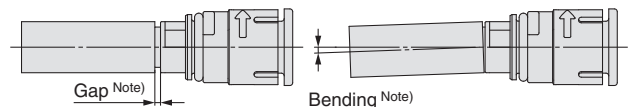

- Put the filter back into the filter case following this procedure in reverse.
- To mount the vacuum port adapter into the filter case, turn the adapter so that the mating mark of the adapter and the case are aligned. (Rotation stops there.)

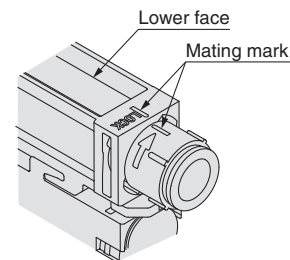

- If it is difficult to remove the vacuum port adapter, you can remove the adapter with a hexagon wrench using the hexagonal hole in V port. The table shows the port size and the width across flats.

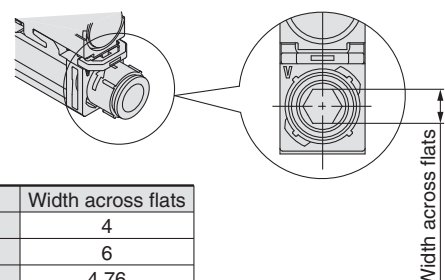

V port size	Width across flats
ø6	4
ø8, 5/16"	6
ø1/4"	4.76



Series ZK2

Specific Product Precautions 3

Be sure to read the below before handling. Refer to back cover for Safety Instructions. For Vacuum Equipment Precautions, refer to "Handling Precautions for SMC Products"(M-E03-3) and Operation Manual. The Operation Manual can be downloaded from the SMC website, <http://www.smcworld.com>

Suction Filter

Caution

2. Filter case maintenance

- When the filter case is dirty, it can be removed and cleaned.

To remove the filter case, insert a precision screwdriver into the groove of the release lever and push in direction (①), and slide the filter case in direction (②).

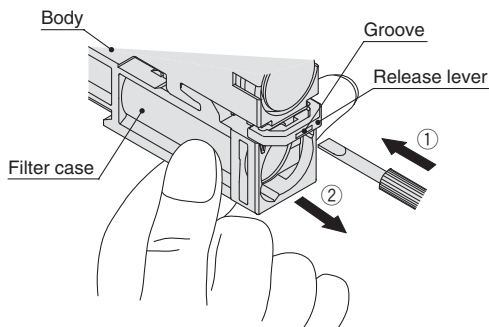

Note) Surface A of the filter case is the sealing surface when vacuum is generated. Handle with care so that the surface is not scratched or damaged.

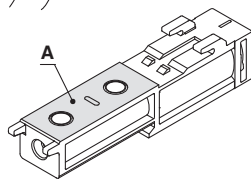

Note) Filter case is made of polycarbonate. Avoid chemicals such as thinner, carbon tetrachloride, chloroform, acetic ester, aniline, cyclohexane, trichloroethylene, sulfuric acid, lactic acid, water base cutting fluid (alkaline).

Note) Do not expose the filter case to direct sunlight for a long period of time.

- Put the filter case back into the ejector by the following procedure.

- 1) Make sure that body gasket (B) and the check valve are installed correctly onto the ejector. If they are out of the place, vacuum leakage may occur.

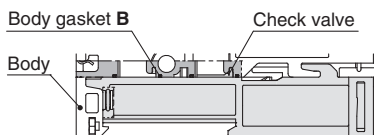

- 2) Push the filter case in direction (①). Be careful the filter case hook (A) and hook (B) do not touch the body of the ejector.
- 3) Slide the filter case in direction (②) while pushing the filter case gently in contact with the ejector. Make sure that the clip (C) is locked and there is no gap in part (D).

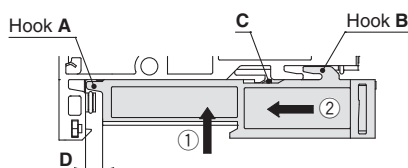

Note) If excess force is applied to the filter case, hook A and B may break. Handle with care.

Ejector Exhaust

Caution

- The exhaust resistance should be as small as possible to obtain the full ejector performance. There should be no shield around the exhaust port for the silencer exhaust specification. When the product is installed, one of the ports should be open to atmosphere.

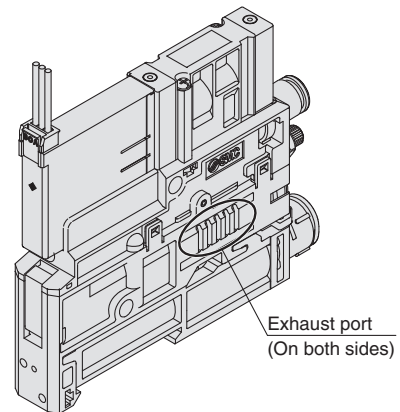

For the port exhaust specification, back pressure may increase depending on the piping size and length. Ensure that the back pressure does not exceed 0.005 MPa (5 kPa).

- If the sound absorbing material is clogged, it will cause a reduction in the ejector performance. Sometimes, if the operating environment contains a lot of particles or mist, the replacement of the filter element only is not enough to recover vacuum performance - as the sound absorbing material may be clogged. Please replace the sound absorbing material. (Regular replacement of the filter element and sound absorbing material is recommended.)

Replacement Procedure for Sound Absorbing Material

- 1) Remove the filter case following the procedure of filter case maintenance.
- 2) Flip the ejector, push the release lever again with a finger or precision screwdriver until the release lever stops.

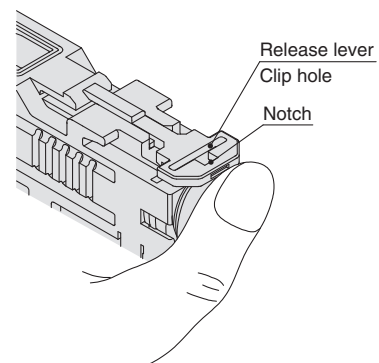



Series ZK2

Specific Product Precautions 4

Be sure to read the below before handling. Refer to back cover for Safety Instructions. For Vacuum Equipment Precautions, refer to "Handling Precautions for SMC Products"(M-E03-3) and Operation Manual. The Operation Manual can be downloaded from the SMC website, <http://www.smcworld.com>

Ejector Exhaust

Caution

- To remove the clip that holds the port plug, insert a precision screwdriver from the release lever notch. Move the screwdriver in direction (1) to pull out the clip in direction (2).

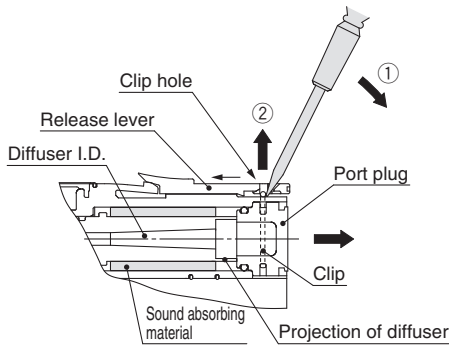

- Remove the port plug. Slide back the release lever.
- Remove the sound absorbing material from the slit (hole) at the side of the body by using a precision screwdriver.
- Insert the new sound absorbing material. Be careful not to scratch the material with the projection of the diffuser assembly.

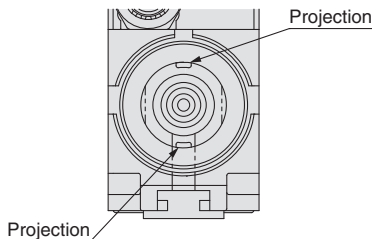

Diffuser hole viewed from the port plug

(Procedure to put parts back together)

- Insert the port plug.
- Push the release lever until it stops. Insert the clip into the groove using the lever hole. (Push completely to the end.)
Note) Do not pull or bend the two projections at the end surface of the diffuser. These are spacers to prevent the displacement of the diffuser and they may break if force is applied.

Operating Supply Pressure

Caution

- Use the product within the specified supply pressure range. Operation over the maximum operating pressure can cause damage to the product. The parts around the vacuum port of this product are designed to be used with vacuum pressure. With the vacuum pump system, since air is not released to the atmosphere from a silencer, the applied air for vacuum release increases the internal pressure of the vacuum port. Select the vacuum pad which shape allows smooth exhaust of release air to the atmosphere and avoid clogging.

Exhaust Noise

Caution

- When vacuum ejector generates vacuum, noise can be heard from the exhaust port when the standard supply pressure is close to the pressure that generates peak vacuum pressure making vacuum pressure unstable. If the vacuum pressure range is adequate for adsorption, there should not be a problem. If the noise causes a problem or affects the setting of the pressure switch, change the supply pressure slightly to avoid the pressure range of the noise.

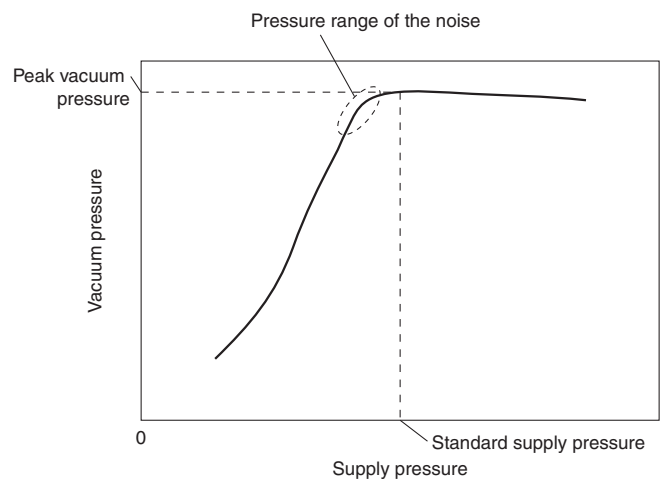

Port Size of Single Unit

Caution

- Port size

Port	Size			
	Ejector System		Vacuum Pump System	
	Metric	Inch	Metric	Inch
PV	ø6	ø1/4"	ø6	ø1/4"
V	ø6, ø8	ø1/4", ø5/16"	ø6, ø8	ø1/4", ø5/16"
EXH (Port exhaust)	ø8	ø5/16"	—	—
PE	EXH Common		Port open to atmosphere *1)	
PS	—	—	ø4	ø5/32"
PD *2)	M3	—	M3	—

— : Not applicable

*1) Piping for PE port is available as an option. (Refer to page 2.)

*2) With PD port type is available as an option. (Refer to page 2.)

How to Order

Specifications/
Flow-rate Characteristics

Port Layout

Construction

Exploded View of Manifold

Dimensions

Specific Product Precautions



Series ZK2

Specific Product Precautions 5

Be sure to read the below before handling. Refer to back cover for Safety Instructions. For Vacuum Equipment Precautions, refer to "Handling Precautions for SMC Products"(M-E03-3) and Operation Manual. The Operation Manual can be downloaded from the SMC website, <http://www.smcworld.com>

How to Mount a Single Unit

⚠ Caution

1. Single unit can be mounted to DIN rail or wall using the holes in the body (2 x $\phi 4.5$).

- When mounting the ejector to DIN rail, unlock the filter case assembly beforehand. (Refer to maintenance procedure on page 29.)
- Hook the ejector onto the DIN rail from direction (1).
- Mount the ejector onto the DIN rail by pushing it down in direction (2).
- Push the filter case assembly in direction (3) until it is locked.

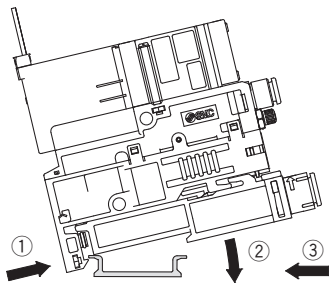

- To hold the ejector onto the DIN rail, hold it from both sides using the stopper brackets.

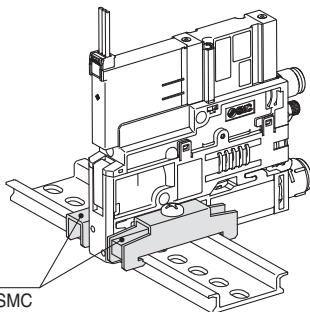

2. To mount a single unit onto the floor, use the optional bracket.

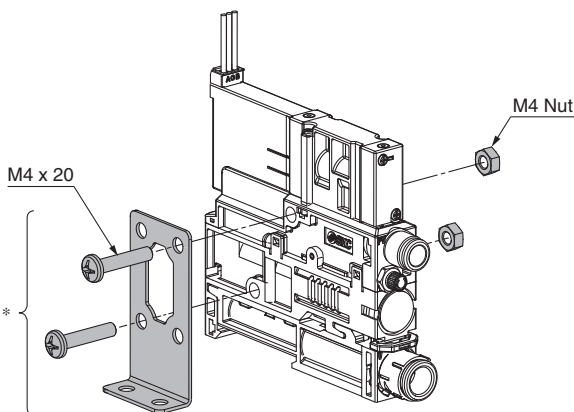

* Mounting bracket for single unit (Option), [Nuts and bolts are included.]
Part number: ZK2-BK1-A

How to Mount a Manifold

⚠ Caution

- Manifolds can be mounted onto the floor using M4 holes on the end plate.
- It is possible to mount the manifold onto the DIN rail by manifold option.
 - Hook the mounting bracket of the end plate to DIN rail from direction (1).
 - Mount the ejector onto the DIN rail by pushing it down in direction (2).
 - Use a 50 mm or longer phillips head screwdriver to tighten the mounting bracket (3). (Tightening torque: 0.9 ± 0.1 N·m)
 - Removal should be performed by following the mounting procedure in reverse.

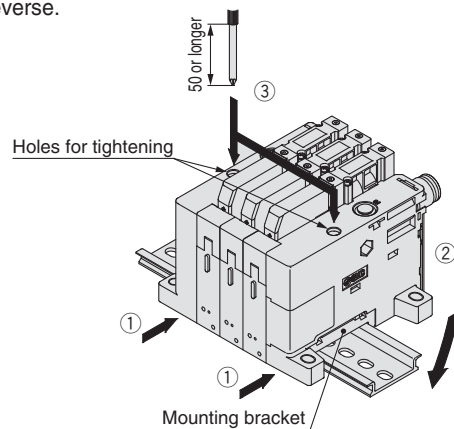

Manifold Silencer

⚠ Caution

- Ejector system manifold silencer common exhaust type has a sound absorbing material in the end plate. If the sound absorbing material is clogged, ejector performance is deteriorated, leading to suction failure or response delay. Regular replacement of the sound absorbing material is recommended.

Replacement Procedure

- Insert a precision screwdriver to notch (A) of the end plate and remove a clip (L) (1).
- Insert a precision screwdriver to notch (B) and remove the silencer cover (2).
- Pull out the sound absorbing material from the silencer cover (3).
- Mounting of a new element should be performed by following the removal procedure in reverse.

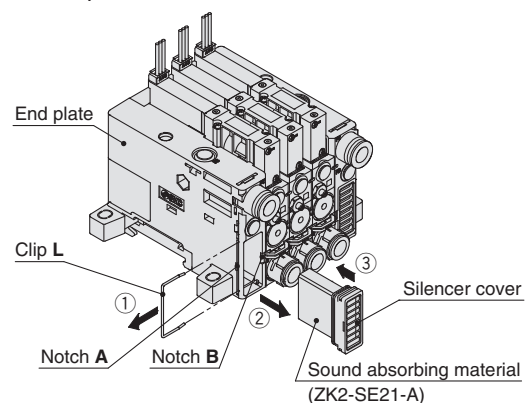



Series ZK2

Specific Product Precautions 6

Be sure to read the below before handling. Refer to back cover for Safety Instructions. For Vacuum Equipment Precautions, refer to "Handling Precautions for SMC Products"(M-E03-3) and Operation Manual. The Operation Manual can be downloaded from the SMC website, <http://www.smcworld.com>

Manifold Ports

⚠ Caution

- Manifold ports are common at the end plate. Port description and application are the same as the single unit. (Refer to page 14 for application and operating pressure range of each port.)
- Refer to page 5 for the number of stations that can operate simultaneously for each ejector size.
- If one side is not used for air supply, plug the unused port or change to the dedicated port plug as shown below.

	Standard	Plug part number
Common PV port	ø8 One-touch	VVQZ2000-CP
Common PS port	ø6 One-touch	ZK2-MP1C6-A
Common PD port		

* There are 4 types depending on the manifold port specification.

	Common EXH port	Common PS/PD ports	Application
ZK2□-A□1□	Yes	PS = PD	Ejector common exhaust + PV = PS = PD specification
ZK2□-A□1□-D	Yes	PS ≠ PD	Ejector common exhaust + PV = PS ≠ PD specification
ZK2□-A□2□ ZK2□-P2□	None	PS = PD	Ejector individual exhaust + PV = PS = PD Pump system + PV ≠ PS = PD
ZK2□-A□2□-D ZK2□-P2□-D	None	PS ≠ PD	Ejector individual exhaust + PV = PS ≠ PD Pump system + PV ≠ PS ≠ PD

- When PS = PD, the common PS/PD ports on the end plate are used, PS port is equipped with one-touch fitting and PD port is plugged at the time of shipment from the factory. Since the PS and PD are connected inside the end plate, common supply location can be changed by exchanging the one-touch fitting and the plug.
- When PS ≠ PD, PS and PD are not connected inside the end plate. (It is necessary to supply each port individually.)

Vacuum Break Flow Adjustment Needle

⚠ Caution

1. **The flow-rate characteristics show the representative values of the product itself.**

They may change depending on piping, circuit and pressure conditions, etc. The flow-rate characteristics and the number of needle rotations vary due to the range of the specifications of the product.

2. **The needle has a retaining mechanism, so it will not turn further when it reaches the rotation stop position.**
Turning the needle too far may cause damage.
3. **Do not tighten the handle with tools such as nippers.**
This can result in breakage due to idle turning.
4. **Do not over tighten the lock nut.**
It is possible to tighten the standard lock nut (hexagon) manually. When tightening further with tools, tighten by approximately 15° to 30°. Over tightening may cause breakage.
5. **When screwdriver operation type needle is selected as option (-K), make sure the lock nut is not loose to prevent the nut from coming off due to vibration.**

■ Handling of Pressure Sensor Assembly

Handling

⚠ Caution

1. **Do not drop, bump or apply excessive impact (980 m/s²) when handling.**

Even if the sensor body is not damaged, the internal parts may get damaged, leading to malfunction.

2. **The tensile strength of the power cord is within 50 N, and pulling it with a greater force can cause failure.**

Hold the body when handling the product.

3. **Refer to the Operation Manual of the pressure sensor PSE540 series for how to connect the connectors for sensor.**

Environment

⚠ Caution

1. **The use of resin piping can cause static electricity to be generated, depending on the fluid.**

Therefore, when connecting this sensor, take appropriate measures against static electricity at the equipment side to which this product is mounted, and separate the grounding for the product from the grounding for any equipment which generates a strong electromagnetic noise or high frequency. Otherwise, static electricity can break the sensor.

■ Handling of Pressure Switch for Vacuum Assembly

Handling

⚠ Caution

1. **Do not drop, bump or apply excessive impact (100 m/s²) when handling.**

Even if the sensor body is not damaged, the internal parts may get damaged, leading to malfunction.

2. **The tensile strength of the power cord is within 35 N, and pulling it with a greater force can cause failure.**

Hold the body when handling the product.

3. **Do not allow repeated bending or stretching forces to be applied to lead wires.**

Wiring arrangements in which repeated bending stress or stretching force is applied to the lead wires can cause broken wires.

If the lead wire can move, fix it near the body of the product. The recommended bending radius of the lead wire is 6 times the outside diameter of the sheath, or 33 times the outside diameter of the insulation material, whichever is larger. Replace the damaged lead wire with a new one. For details, please consult with SMC.

How to Order

Specifications/
Flow-rate Characteristics

Port Layout

Construction

Exploded View of Manifold

Dimensions

Specific Product Precautions

Specific Product Precautions 7

Be sure to read the below before handling. Refer to back cover for Safety Instructions. For Vacuum Equipment Precautions, refer to "Handling Precautions for SMC Products"(M-E03-3) and Operation Manual. The Operation Manual can be downloaded from the SMC website, <http://www.smcworld.com>



■ Handling of Pressure Switch for Vacuum Assembly

Handling

⚠ Caution

- 1. Incorrect wiring can cause the switch to be damaged or malfunction. Connections should only be made when the power supply is turned off.**
- 2. Do not attempt to insert or pull out the connector from the switch while the power is on.**
Otherwise, it may cause switch output malfunction.
- 3. Malfunctions stemming from noise may occur if the wire is installed in the same route as that of power or high-voltage cable.**
Wire the switch independently.
- 4. Be sure to connect the ground terminal F.G. to ground when using a commercially available switching power supply.**

Environment

⚠ Warning

- 1. The structure of pressure switches is not intended to prevent explosion.**
Never use in an atmosphere of flammable gas or explosive gas.

⚠ Caution

- 1. The product is CE marked, but not immune to lightning strikes.**
Take measures against lightning strikes in your system.
- 2. Do not use the switches in locations where static electricity would be problematic.**
Otherwise, it may result in the system failure and trouble.

Assembling/Removing Connectors

⚠ Caution

- When assembling the connector to the switch housing, push the connector straight onto the pins until the level locks into the housing slot.
- When removing the connector from the switch housing, push the section A (lever) down with your thumb to unlock it from the slot and then withdraw the connector straight off of the pins.

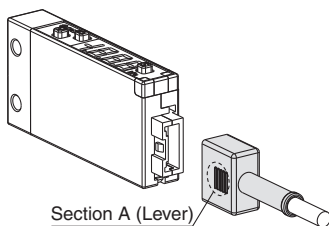

- Do not attempt to insert or pull out the connector from the switch while the power is on. Otherwise, it may cause switch output malfunction.

■ Handling of Digital Pressure Switch with Energy Saving Function

Mounting

⚠ Caution

- 1. Tighten to the specified tightening torque.**
If the tightening torque is exceeded, the mounting screws and the pressure switch may break. Insufficient torque may cause displacement of the pressure switch and loosening of the mounting screws.
Tightening torque: 0.08 to 0.10 N·m
- 2. If a commercially available switching power supply is used, be sure to ground the frame ground (FG) terminal.**
- 3. Do not drop, hit or apply shock to the product.**
The internal parts of the pressure switch may get damaged and cause malfunction.
- 4. Do not pull the lead wire with force, or lift the product by pulling the lead wire. (Tensile strength within 20 N)**
Hold the product body when handling to prevent damage, failure or malfunction.
The pressure switch will be damaged, leading to failure and malfunction.
- 5. Eliminate any dust left in the piping by using a blast of air before connecting the piping to the product.**
Failure or malfunction may occur.
- 6. Do not insert metal wires or other foreign objects into the pressure port.**
The pressure sensor may get damaged, leading to failure and malfunction.
- 7. If the fluid contains foreign matter, install and connect a filter or mist separator to the inlet.**
Failure, malfunction or inaccurate measurements from the pressure switch may occur.



Other Tube Brands

⚠ Caution

- 1. When tubing of brands other than SMC's are used, verify that the tubing O.D. satisfies the following accuracy;**
 - 1) Nylon tubing: Within ± 0.1 mm
 - 2) Soft nylon tubing: Within ± 0.1 mm
 - 3) Polyurethane tubing: Within $+0.15$ mm, within -0.2 mm
Do not use tubing which does not meet these outside diameter tolerances.
It may not be possible to connect them, or they may cause other trouble, such as air leakage or the tube pulling out after connection.

Safety Instructions

These safety instructions are intended to prevent hazardous situations and/or equipment damage. These instructions indicate the level of potential hazard with the labels of “**Caution**,” “**Warning**” or “**Danger**.” They are all important notes for safety and must be followed in addition to International Standards (ISO/IEC)*1, and other safety regulations.

-  **Caution:** **Caution** indicates a hazard with a low level of risk which, if not avoided, could result in minor or moderate injury.
-  **Warning:** **Warning** indicates a hazard with a medium level of risk which, if not avoided, could result in death or serious injury.
-  **Danger :** **Danger** indicates a hazard with a high level of risk which, if not avoided, will result in death or serious injury.

- *1) ISO 4414: Pneumatic fluid power – General rules relating to systems.
ISO 4413: Hydraulic fluid power – General rules relating to systems.
IEC 60204-1: Safety of machinery – Electrical equipment of machines.
(Part 1: General requirements)
ISO 10218-1: Manipulating industrial robots – Safety.
etc.

Warning

- 1. The compatibility of the product is the responsibility of the person who designs the equipment or decides its specifications.**
Since the product specified here is used under various operating conditions, its compatibility with specific equipment must be decided by the person who designs the equipment or decides its specifications based on necessary analysis and test results. The expected performance and safety assurance of the equipment will be the responsibility of the person who has determined its compatibility with the product. This person should also continuously review all specifications of the product referring to its latest catalog information, with a view to giving due consideration to any possibility of equipment failure when configuring the equipment.
- 2. Only personnel with appropriate training should operate machinery and equipment.**
The product specified here may become unsafe if handled incorrectly. The assembly, operation and maintenance of machines or equipment including our products must be performed by an operator who is appropriately trained and experienced.
- 3. Do not service or attempt to remove product and machinery/equipment until safety is confirmed.**
 1. The inspection and maintenance of machinery/equipment should only be performed after measures to prevent falling or runaway of the driven objects have been confirmed.
 2. When the product is to be removed, confirm that the safety measures as mentioned above are implemented and the power from any appropriate source is cut, and read and understand the specific product precautions of all relevant products carefully.
 3. Before machinery/equipment is restarted, take measures to prevent unexpected operation and malfunction.
- 4. Contact SMC beforehand and take special consideration of safety measures if the product is to be used in any of the following conditions.**
 1. Conditions and environments outside of the given specifications, or use outdoors or in a place exposed to direct sunlight.
 2. Installation on equipment in conjunction with atomic energy, railways, air navigation, space, shipping, vehicles, military, medical treatment, combustion and recreation, or equipment in contact with food and beverages, emergency stop circuits, clutch and brake circuits in press applications, safety equipment or other applications unsuitable for the standard specifications described in the product catalog.
 3. An application which could have negative effects on people, property, or animals requiring special safety analysis.
 4. Use in an interlock circuit, which requires the provision of double interlock for possible failure by using a mechanical protective function, and periodical checks to confirm proper operation.

Caution

- 1. The product is provided for use in manufacturing industries.**
The product herein described is basically provided for peaceful use in manufacturing industries.
If considering using the product in other industries, consult SMC beforehand and exchange specifications or a contract if necessary.
If anything is unclear, contact your nearest sales branch.

Limited warranty and Disclaimer/ Compliance Requirements

The product used is subject to the following “Limited warranty and Disclaimer” and “Compliance Requirements”.

Read and accept them before using the product.

Limited warranty and Disclaimer

1. The warranty period of the product is 1 year in service or 1.5 years after the product is delivered, whichever is first.*2)
Also, the product may have specified durability, running distance or replacement parts. Please consult your nearest sales branch.
2. For any failure or damage reported within the warranty period which is clearly our responsibility, a replacement product or necessary parts will be provided.
This limited warranty applies only to our product independently, and not to any other damage incurred due to the failure of the product.
3. Prior to using SMC products, please read and understand the warranty terms and disclaimers noted in the specified catalog for the particular products.
***2) Vacuum pads are excluded from this 1 year warranty.**
A vacuum pad is a consumable part, so it is warranted for a year after it is delivered.
Also, even within the warranty period, the wear of a product due to the use of the vacuum pad or failure due to the deterioration of rubber material are not covered by the limited warranty.

Compliance Requirements

1. The use of SMC products with production equipment for the manufacture of weapons of mass destruction (WMD) or any other weapon is strictly prohibited.
2. The exports of SMC products or technology from one country to another are governed by the relevant security laws and regulations of the countries involved in the transaction. Prior to the shipment of a SMC product to another country, assure that all local rules governing that export are known and followed.

 **Safety Instructions** Be sure to read “Handling Precautions for SMC Products” (M-E03-3) before using.

SMC Corporation

Akihabara UDX 15F,
4-14-1, Sotokanda, Chiyoda-ku, Tokyo 101-0021, JAPAN
Phone: 03-5207-8249 Fax: 03-5298-5362
<http://www.smcworld.com>
© 2013 SMC Corporation All Rights Reserved

Specifications are subject to change without prior notice and any obligation on the part of the manufacturer.

D-G

1st printing RQ printing RQ 8150SZ Printed in Japan.