

REV.	DESCRIPTION	DATE	APPROVED
B	Engineering Update w/o Changes	02/13/04	M. C.
C	Updated Part Offering List	10/10/13	G. W.

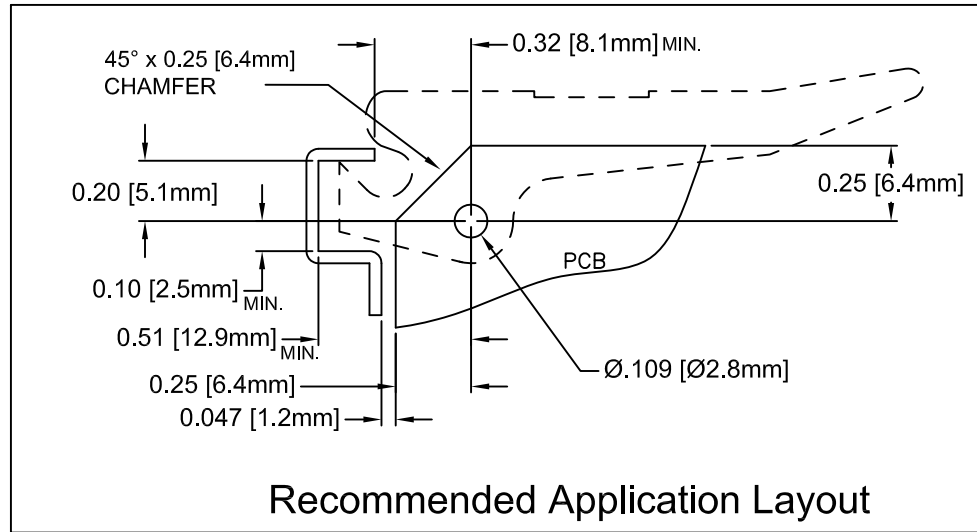
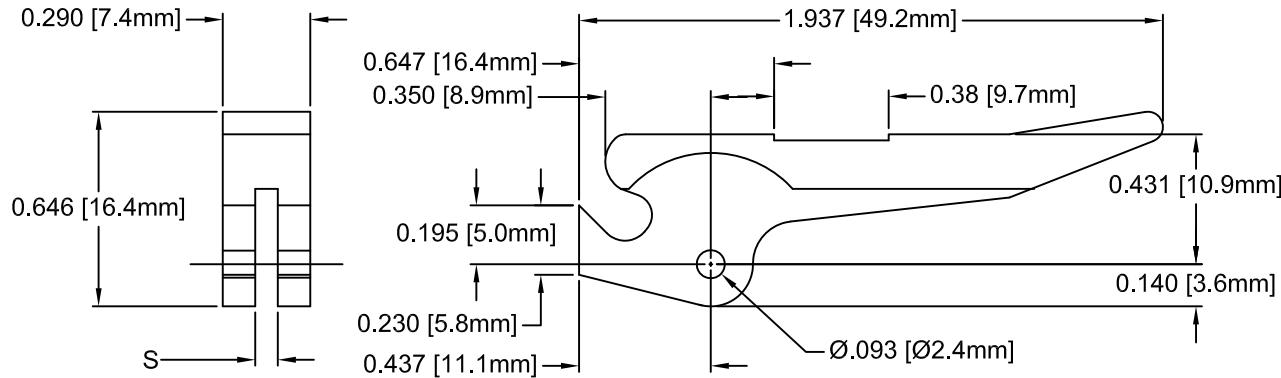

PART NO.	COLOR	S	PCB THICKNESS
1001-062 NT	NATURAL	.075"(1.9mm)	.062"(1.6mm)
1001-062 BK	BLACK		
1002-093 NT	NATURAL	.100"(2.5mm)	.093"(2.4mm)
1002-093 BK	BLACK		

3. MATERIAL: NYLON 6/6, 94V-2, BLACK. BIVAR MATERIAL CODE 03-NL-BK. BASF ULTRAMID NYLON 6/6 A3K NATURAL W/BLACK PIGMENT ADDED.
2. MATERIAL: NYLON 6/6, 94V-2, NATURAL. BIVAR MATERIAL CODE 03-NL. BASF ULTRAMID NYLON 6/6 A3K NATURAL.
1. GENERAL SPECIFICATIONS: BIVAR MOLDED COMPONENT SPECIFICATION BV00-E101.

STANDARD TOLERANCE (UNLESS OTHERWISE SPECIFIED)		BIVAR [®] 4 THOMAS, IRVINE, CA. 92618 TEL: (949) 951-8808 FAX: (949) 951-3974	
DECIMALS	ANGULAR		
.X ±.1	X° ± 1°	TITLE: PCB INSERTER/EXTRACTOR	
.XX ±.01			
.XXX ±.005			
DESIGNED: Michael Chen	DATE: 02/24/03	PART NO: 100X-XXX XX	REVISION: C
CHECKED: D. Green	DATE: 02/25/03	CAGE CODE : 32559	SHEET # 1 OF 1
CAD GENERATED DOCUMENT, DO NOT MEASURE DRAWING.			