

REVISIONS					
REV	ECO	DESCRIPTION	DATE	BY	APPR
A1	-	RELEASE NEW PRODUCT	24/MAY/23	HAILEY	TOMMY

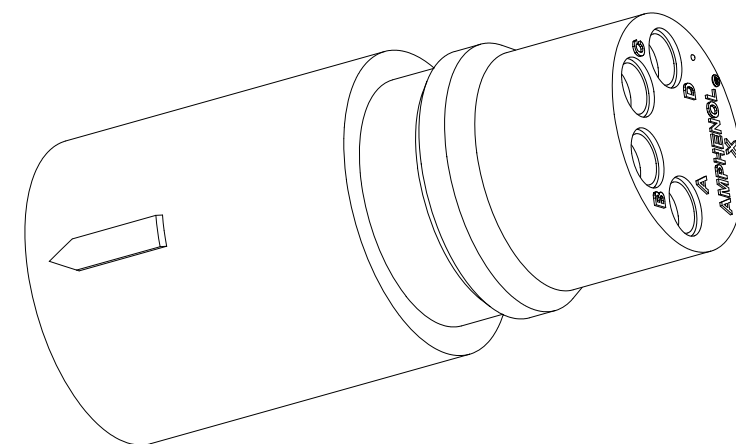
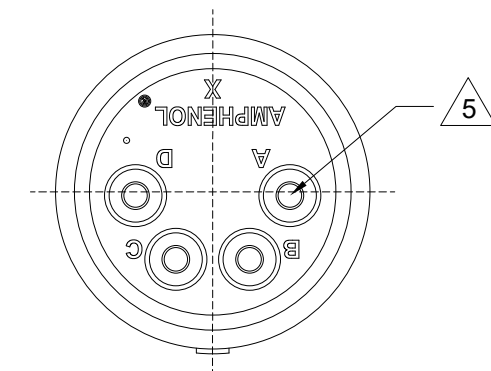
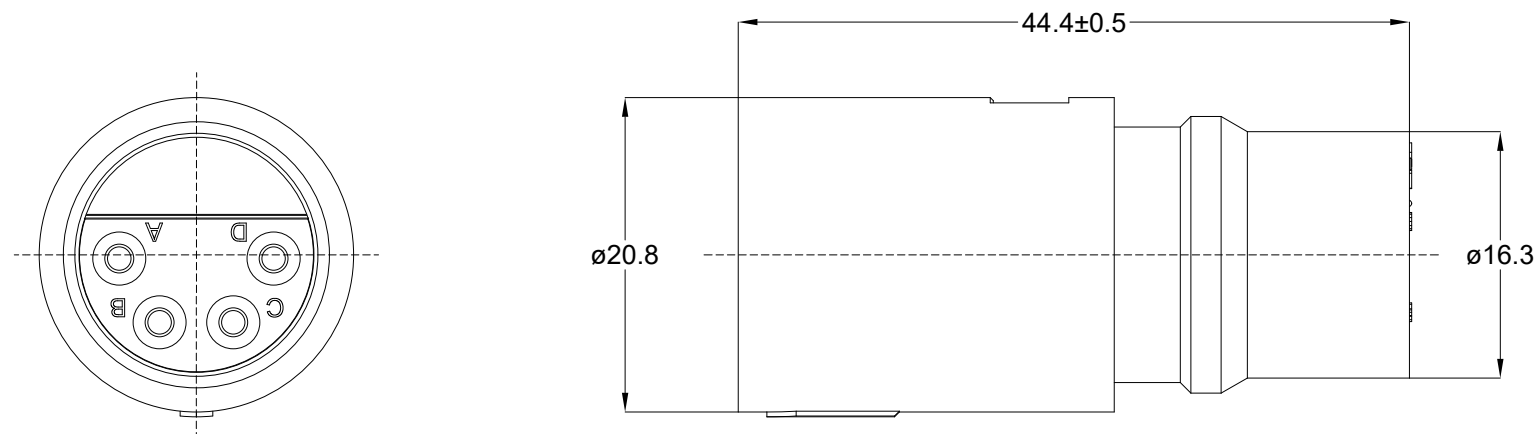

NOTES: UNLESS OTHERWISE SPECIFIED

- MATERIAL:  
THERMOPLASTIC ELASTOMER  
COLOR:BLACK
- SPECIFICATIONS:
  - CURRENT RATING: 8 AMPS
  - RATED VOLTAGE: 250V AC/DC
  - OPERATING TEMPERATURE: -40°C TO +105°C
  - DIELECTRIC WITHSTANDING VOLTAGE: LESS THAN 2 MILLIAMPS CURRENT LEAKAGE @ 1500 VOLTS AC.
  - INSULATION RESISTANCE: 5000 MEGOHMS MIN @ 25°C.
  - MOISTURE RESISTANCE: IP67 ( MATED CONDITION )
  - MATING CYCLE DURABILITY: 25 CYCLES
  - RoHS COMPLIANT
- MATING PART IS 044-103-10004.
- ALL DIMENSIONS ARE FOR REFERENCE USE ONLY.

5 CONTACT SIZE AND REAR SEAL WIRE RANGE:

CONTACT SIZE	MIN. INSUL O.D.	MAX. INSUL O.D.	TYPICAL WIRE RANGE
14	2.03 mm (.079 in)	3.30 mm (.129 in)	14 - 18 AWG (2.5-1.0mm <sup>2</sup> )

TITLE: 44 SERIES RECEPTACLE CONNECTOR, 1 CONTACTS, STANDARD TYPE  
 DWG NO.: 0441041000402  
 REV: A1  
 SH: 1  
 OF: 1

044-104-10004-02		DESCRIPTION		ITEM
PART NUMBER				
QUANTITY	MATERIALS LIST			
UNLESS OTHERWISE SPECIFIED		SIGNATURES		DATE
1) All dimensions are in metric(mm).		DRAWN: HAILEY	25/MAY/23	
2) Tolerances are as follows:		CHECKED: ORION	25/MAY/23	
1 PL DEC ±0.30		FRACTIONS ±1/64		
2 PL DEC ±0.15		ANGLES ±1°		
3 PL DEC ±0.08		3) Note reference = X		
MATERIAL SPECIFICATIONS:		APPROVAL: TOMMY		25/MAY/23
PROCESS SPECIFICATIONS:		CUSTOMER:		
NEXT ASSY:		THIS DRAWING IS SUPPLIED FOR INFORMATION ONLY. DESIGN FEATURES, SPECIFICATIONS AND PERFORMANCE DATA SHOWN HEREON ARE THE PROPERTY OF THE AMPHENOL CORPORATION. NO RIGHTS OF REPRODUCTION ARE IMPLIED. ALL DIMENSIONS ARE SUBJECT TO NORMAL MANUFACTURING VARIATIONS.		
		<b>Amphenol</b> Sine Systems - www.amphenol-sine.com 44724 Morley Drive Clinton Township, MI 48036		
		<b>44 SERIES RECEPTACLE CONNECTOR, 4 CONTACTS, STANDARD TYPE</b>		
SIZE	TYPE	DWG NO.	REVISION	
B	C-	0441041000402	A1	
SCALE: NONE	SHEET 1 OF 1			