



Price index



IPA Qualification Certificate:
Air Cleanless Class ISO Class 2
(at v = 1 m/s) upon request



UL94-V2
classifications



Torsional
motion possible



Special equipment:
Electrically conductive ESD/ATEX
version upon request



Low-noise
due small pitch



Just push the cables into the e-chain®
with your thumb - and it's ready



When to use the Series E16/Z16:

- If filling is required without opening and closing lids
- If price is an issue
- If quiet operation is required



When not to use it:

- For applications with very high loads and long unsupported travel lengths
▶ Series 2600/2650/2680/2700 E2/000, page 5.182
- If an e-chain® is needed with a high locking crossbar
▶ Series 2600/2650/2680/2700 E2/000, page 5.182

- ❶ Limited torsion tolerance
- ❷ Small pitch for low-noise, smooth operation
- ❸ Very easy to fill - ideal for harnessed cable assemblies
- ❹ Cable-friendly interior
- ❺ "E" Series features split crossbar along the outer radius
- ❻ "Z" Series features split crossbar along the inner radius
- ❼ Mounting brackets with integrated strain relief
- ❽ The patented push-button principle holds the links together



Special solution -
opening gap
Part No. E16.2.100N3



Special solution -
opening gap
Part No. Z16.2.075N3



Order example complete e-chain®

Please indicate chain-lengths or number of links Example: 1 m or 33 links

1 m E16.3.060.0



e-chain®

1 set 117.3.12PZ



Mounting bracket



Unsupported length

FL_G = with straight upper run

FL_B = with permitted sag

Further information ► **Design, page 1.12**

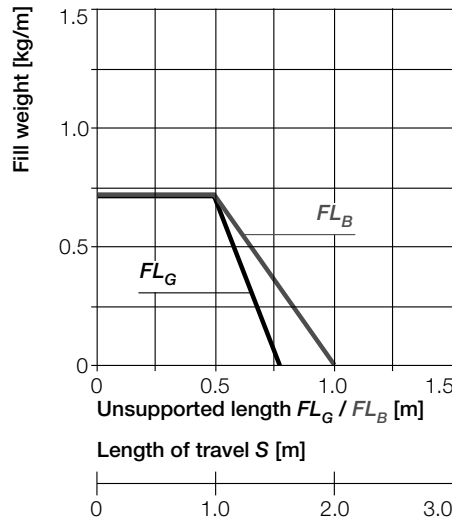
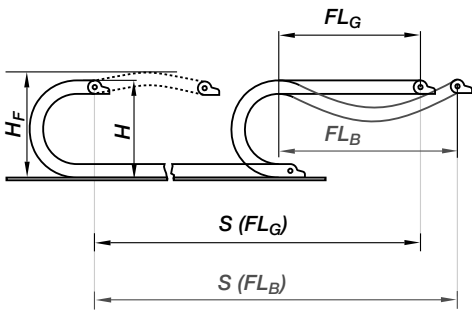

- S = Length of travel
- R = Bending radius
- H = Nominal clearance height
- H_F = Required clearance height
- D = Overlength e-chain® radius in final position
- $K = \pi \cdot R + \text{"safety"}$

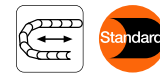
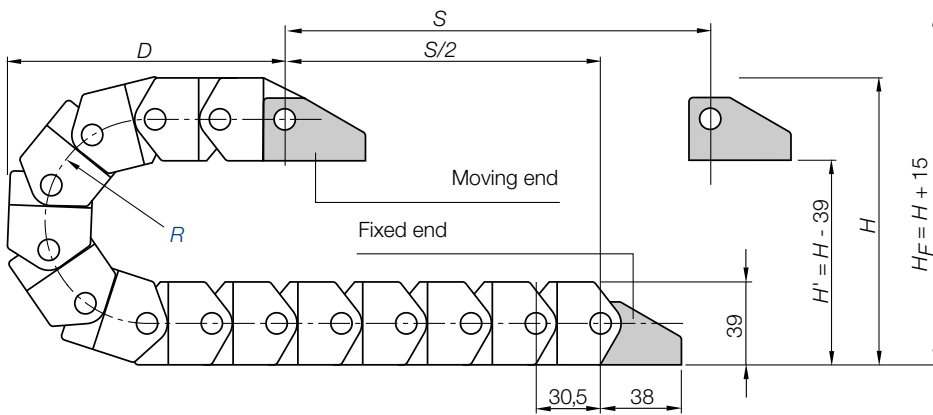

Short travels - unsupported

Unsupported e-chains® feature positive camber over short travels. This must be accounted for when specifying the clearance height H_F . Please consult igus® if space is particularly restricted.

Pitch = 30,5 mm/link Links/m = 33 (1.006,5mm) Chain length = $S/2 + K$

R	040	060	075	100	125*
H	119	159	189	239	289
D	105	125	140	165	190
K	190	250	300	380	455

The required clearance height:
 $H_F = H + 15$ mm
(with 0,3 kg/m fill weight)

Speed / acceleration FL_G	max. 20 [m/s] / max. 200 [m/s ²]
Speed / acceleration FL_B	max. 3 [m/s] / max. 6 [m/s ²]
Gliding speed / acceleration (maximum)	max. 3 [m/s] / max. 10 [m/s ²]
Material (e-chain®)- permitted temperature °C	igumid NB / -40° up to +80° C
Material (mounting brackets)* - permitted temperature °C	igumid G / -40° up to +120° C
Flammability class (e-chain®), igumid NB	VDE 0304 IIC UL94 V2
Flammability class (mounting brackets), igumid G*	VDE 0304 IIC UL94 HB

*Available in igumid NB upon request, please consult igus® for delivery time

Technical Data



Details of material properties
► page 1.38



easy chain®
Inner height: 32 mm

Phone +49- (0) 22 03-96 49-800
Fax +49- (0) 22 03-96 49-222

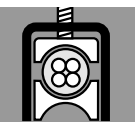

► page 3.5

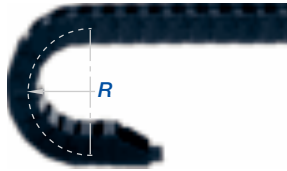
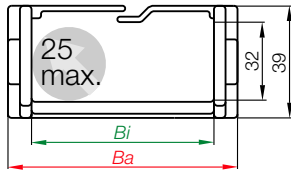

Part No. structure

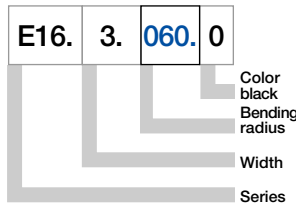

Series E16 - split crossbar along the outer radius

Part No.	Bending radii					Weight [kg/m]
	Bi [mm]	Ba [mm]	R [mm]			
E16.2.□.0	23	37,5	060	075	100	≈ 0,51
E16.3.□.0	36	50,5	060	075	100	≈ 0,57
E16.4.□.0	48	62,5	060	075	100	≈ 0,62
E16.5.□.0	63	78,5	060	075	100	≈ 0,75
E16.6.□.0	80	95,5	060	075	100	≈ 0,83
E16.7.□.0	100	115,3	060	075	100	≈ 0,91

Ba: pin dimension approx. 0,3 - 0,7 mm wider

The bending radius **125** is available upon request.

Delivery time: approx. 3-4 weeks after receipt of order!

Supplement Part No. with required radius. Example: E16.3.**060**.0

0 = standard color, other colors ► page 1.39 · Pitch = 30,5 mm/link - Links/m = 33

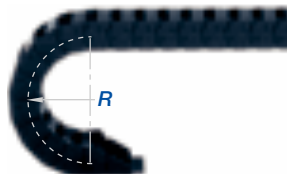
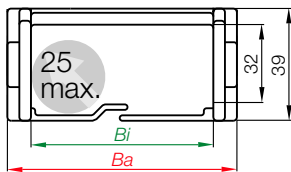

Part No. structure

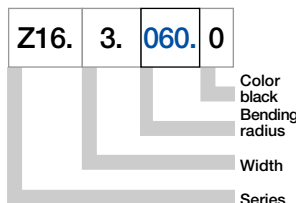

Series Z16 - split crossbar along the inner radius

Part No.	Bending radii					Weight [kg/m]	
	Bi [mm]	Ba [mm]	R [mm]				
Z16.2.□.0	23	37,5	060	075	100	≈ 0,51	
Z16.3.□.0	36	50,5	040	060	075	100	≈ 0,57
Z16.4.□.0	48	62,5	040	060	075	100	≈ 0,62
Z16.5.□.0	63	78,5	060	075	100	≈ 0,75	
Z16.6.□.0	80	95,5	060	075	100	≈ 0,83	
Z16.7.□.0	100	115,3	060	075	100	≈ 0,91	

Ba: pin dimension approx. 0,3 - 0,7 mm wider

The bending radius **125** is available upon request.

Delivery time: approx. 3-4 weeks after receipt of order!

Supplement Part No. with required radius. Example: Z16.3.**060**.0

0 = standard color, other colors ► page 1.39 · Pitch = 30,5 mm/link - Links/m = 33





Polymer, one-piece

- One-piece mounting bracket
- Corrosion-resistant
- Available preassembled
- Inner and outer attachment possible
- Available with integrated strain relief tiwrap plates
- 90° * not for Series Z16

Moving end with bore
(outer link) 117...1P(Z)

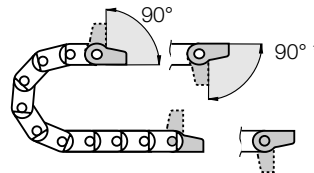

117...2P(Z) Fixed end
with pin (inner link)

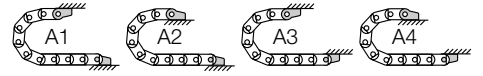

Possible installation conditions for assembled mounting brackets ► Order example "preassembled" below

117...1P(Z)
Moving end

117...2P(Z)
Fixed end

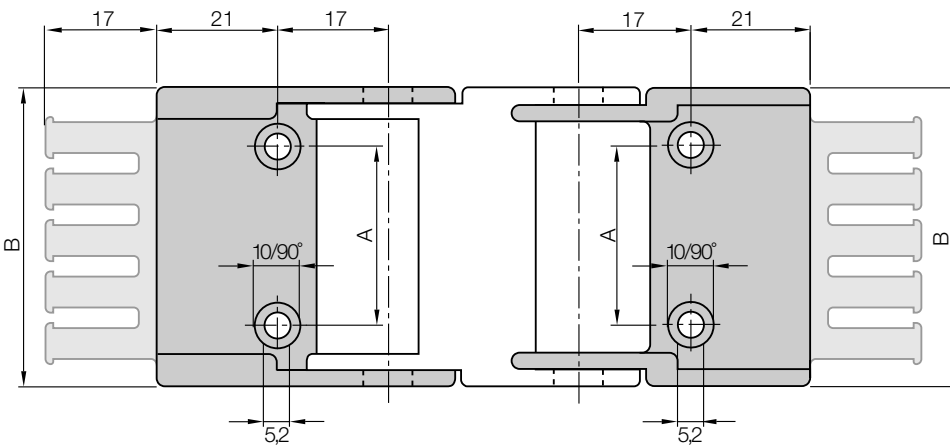

Dimensions and order configurations

Strain relief is possible on the moving end and/or the fixed end.

Part No. structure

117. 2. 12 PZ A1

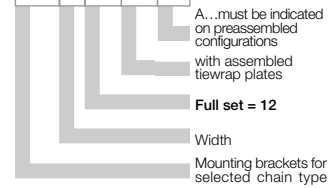

Full set, for both ends:

117. 2. 12 PZ +tiwrap plate

Single-part order:

117. 2. 1 PZ +tiwrap plate

Mounting bracket with bore

117. 2. 2 PZ +tiwrap plate

Mounting bracket with pin

For e-chain®	Part No. full set with tiwrap plate	Part No. full set without tiwrap plate	Number of teeth	Dim. A [mm]	Dim. B [mm]
E16-Z16.2. ►	117. 2. 12PZ	117. 2. 12P	3	12	35,5
E16-Z16.3. ►	117. 3. 12PZ	117. 3. 12P	4	25	48,5
E16-Z16.4. ►	117. 4. 12PZ	117. 4. 12P	5	37	60,5
E16-Z16.5. ►	117. 5. 12PZ	117. 5. 12P	6	48	76,0
E16-Z16.6. ►	117. 6. 12PZ	117. 6. 12P	8	65	93,0
E16-Z16.7. ►	117. 7. 12PZ	117. 7. 12P	10	85	113,0

Please add the Part No. with the requested index - e.g. 117. 2. 12PZ

For the **preassembled** mode please add the index A1 ... A4 e.g. 117. 2. 12PZ A1

Phone +49- (0) 22 03-96 49-800
Fax +49- (0) 22 03-96 49-222

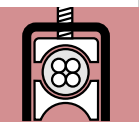
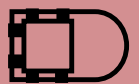

Quicksnap - the complete, detachable mounting unit, available upon request



Quickfix - mounting bracket with dowel, available upon request

Additional Features



► page 3.5