



Tool Containers & CupBoards





TOOL CONTAINERS & CUPBOARDS

- Heavy Duty Tool Cabinets
- Standard Duty Tool Cabinets
- Maintenance Cart
- Mobile Tool Cupboard
- Service Cart



- Recessed worktop

- Central locking system

- Low friction telescopic ball bearing slides; fully accessible drawers.

- Heavy duty oil proof rubber wheels (2 fixed and 2 swivelling, 1 with brake system)





TOOL CONTAINERS & CUPBOARDS

7531573

3 Drawer Heavy Duty Tool Cabinet

- Sturdy and dependable construction, premium quality sheet steel. Elegant and durable electrostatic matt powder coated, scratch proof.
- 6 fully extendible drawers
- Low friction telescopic ball bearing slides ensuring silk smooth operation.
- Central locking mechanism.
- 100 diameter, 2 locking swivel castors and 2 fixed castors

Heavy Duty

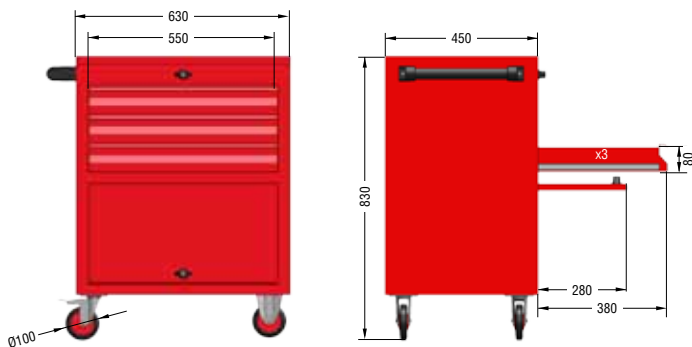

3 drawers

CODE NO	HxWxD / mm	kg
7531573	830 x 630 x 450	39.30

7531576

5 Drawer Heavy Duty Tool Cabinet

- Sturdy and dependable construction, premium quality sheet steel. Elegant and durable electrostatic matt powder coated, scratch proof.
- 5 fully extendible drawers
- Low friction telescopic ball bearing slides ensuring silk smooth operation.
- Central locking mechanism.
- 100 diameter, 2 locking swivel castors and 2 fixed castors

Heavy Duty

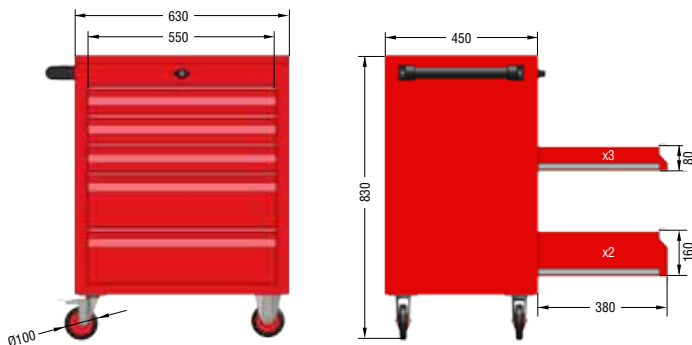

5 drawers

CODE NO	HxWxD / mm	kg
7531576	830 x 630 x 450	45.65



TOOL CONTAINERS & CUPBOARDS

7531570

6 Drawer Heavy Duty Tool Cabinet

- Sturdy and dependable construction, premium quality sheet steel.
Elegant and durable electrostatic matt powder coated, scratch proof.
- 6 fully extendible drawers
- Low friction telescopic ball bearing slides ensuring silk smooth operation.
- Central locking mechanism.
- 100 diameter, 2 locking swivel castors and 2 fixed castors

Heavy Duty

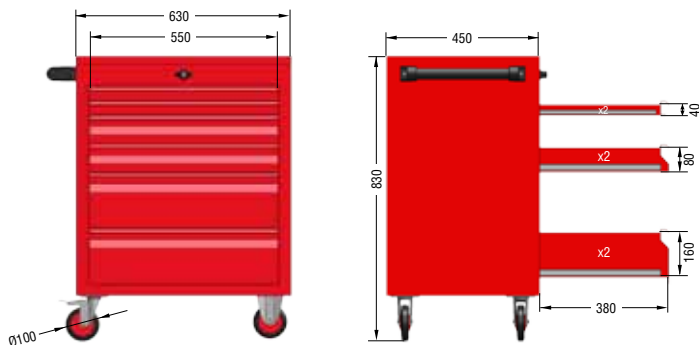

6 drawers

CODE NO	HxWxD / mm	kg
7531570	830 x 630 x 450	47.70

7531589

7 Drawer Heavy Duty Tool Cabinet

- Sturdy and dependable construction, premium quality sheet steel.
Elegant and durable electrostatic matt powder coated, scratch proof.
- 7 fully extendible drawers
- Low friction telescopic ball bearing slides ensuring silk smooth operation.
- Central locking mechanism.
- 100 diameter, 2 locking swivel castors and 2 fixed castors

Heavy Duty

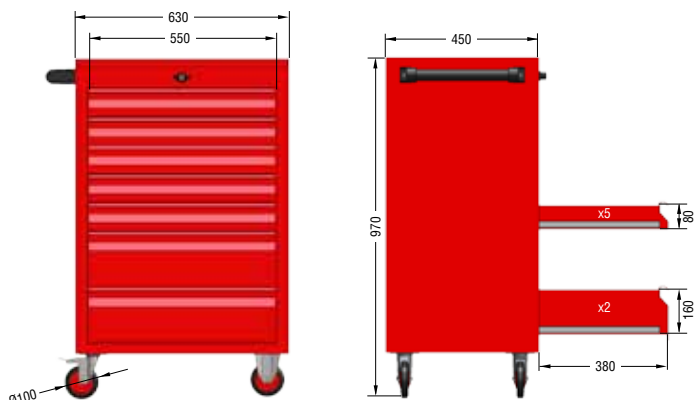

7 drawers

CODE NO	HxWxD / mm	kg
7531589	970 x 630 x 450	58.90



TOOL CONTAINERS & CUPBOARDS

7531582

12 Drawer Maintenance Cart

- Sturdy and dependable construction, premium quality sheet steel. Elegant and durable electrostatic matt powder coated, scratch proof.
- 12 fully extendible drawers
- Low friction telescopic ball bearing slides ensuring silk smooth operation.
- Central locking mechanism.
- 125 diameter, 2 locking swivel castors and 2 fixed castors

Heavy Duty

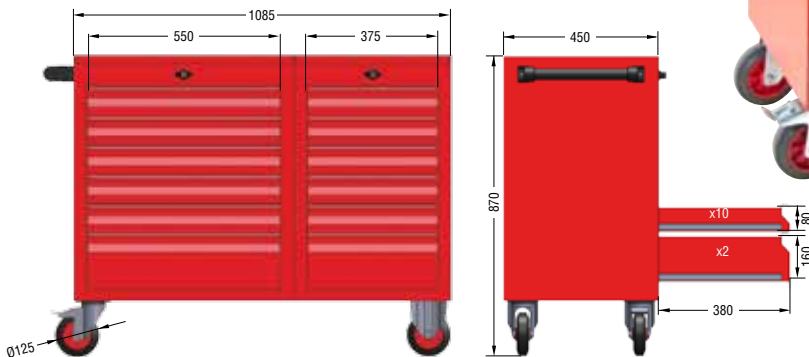

12 drawers

CODE NO	HxWxD / mm	kg
7531582	870x1085x450	87.75

7531592

Service Cart

- Sturdy and dependable construction, premium quality sheet steel. Elegant and durable electrostatic matt powder coated, scratch proof.
- Base, middle and bottom shelves with edges to contain tools.
- 125 diameter, 2 locking swivel castors and 2 fixed castors

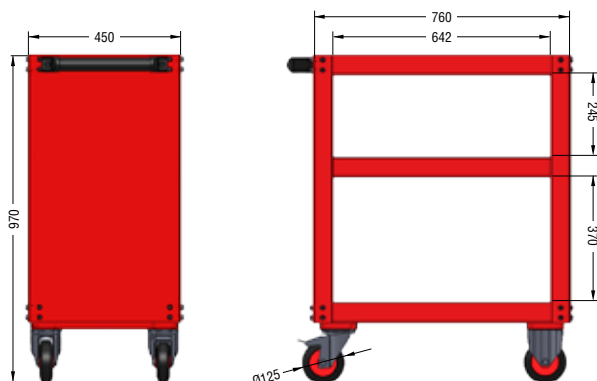

CODE NO	HxWxD / mm	kg
7531592	970 x 760 x 450	31.60



TOOL CONTAINERS & CUPBOARDS

7531586

5 Drawer Standard Duty Tool Cabinet

- Sturdy and dependable construction, premium quality sheet steel.
- Elegant and durable electrostatic matt powder coated, scratch proof.
- 5 fully extendible drawers
- Low friction telescopic ball bearing slides ensuring silk smooth operation.
- Padlock locking mechanism.
- 75 diameter, 2 locking swivel castors and 2 fixed castors

Standard Duty

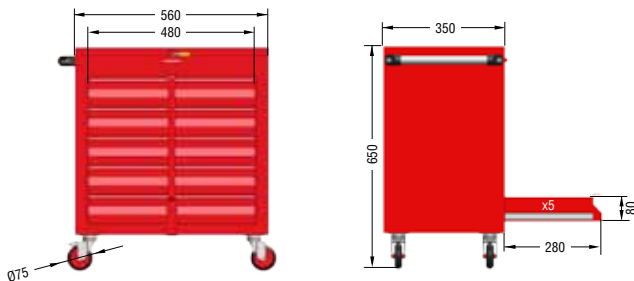

5 drawers

CODE NO	HxWxD / mm	kg
7531586	650 x 560 x 350	28.65

7531595

6 Drawer Standard Duty Tool Cabinet

- Sturdy and dependable construction, premium quality sheet steel.
- Elegant and durable electrostatic matt powder coated, scratch proof.
- 6 fully extendible drawers
- Low friction telescopic ball bearing slides ensuring silk smooth operation.
- Padlock locking mechanism.
- 75 diameter, 2 locking swivel castors and 2 fixed castors

Standard Duty

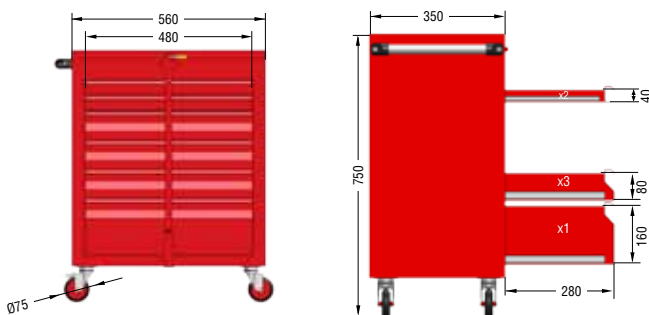

6 drawers

CODE NO	HxWxD / mm	kg
7531595	750 x 560 x 350	33.45



TOOL CONTAINERS & CUPBOARDS

7531598

Mobile Tool Cupboard

- Sturdy and dependable construction, premium quality sheet steel.
- Elegant and durable electrostatic matt powder coated, scratch proof.
- Locking mechanism.
- 75 diameter, 2 locking swivel castors and 2 fixed castors

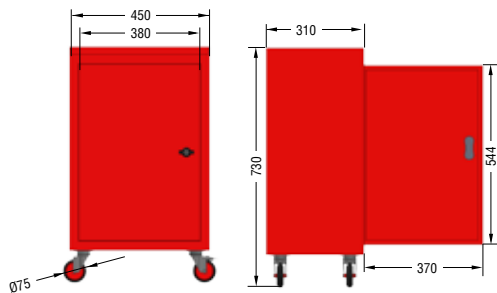

CODE NO	HxWxD / mm	 kg
7531598	730 x 450 x 310	11.95