

RS Stock No: 541-6781

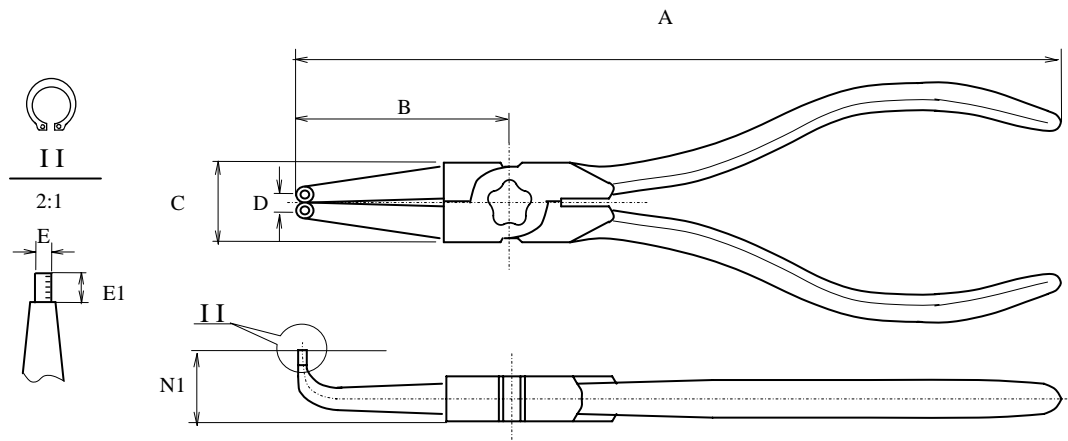

Inspection item	Specification	Inspection tools
A mm	125.6±2	Kaliper
B mm	24.6-1	Kaliper
C mm	15-1	Kaliper
E mm	0.9-0.1	Kaliper
E1 mm	1.5-0.2	Kaliper
D max	(17.1)	Kaliper
N1 mm	13.5±2	Kaliper

MATERIAL: CHROME MOLYBDENUM STEEL FOR PLIERS, SPRING
STEEL FOR AUTOMATIC RETURN FUNCTION AND VINYL DIPPING
HANDLES.

FINISH: CHEMICAL BLACK FINISH WITH POLISH MAIN SURFACE FOR PLIERS,
RED COLOR HANDLE.

HARDNESS: HEAT TREATED TO HRC: 45~55 (CIRCLIP TIP),
HRC: 44~48 (HANDLE) AND HRC: 30~48(JOINT)

CONTENTS:

1 PC - 5" (127 MM) INTERNAL 90 BENT TYPE, SMALL CYLINDRICAL TIP
CIRCLIP PLIERS WITH AUTOMATIC RETURN SPRING AND RED COLOR VINYL
DIPPING GRIP (DIAMETER OF TIP – 0.9MM, OVERALL LENGTH -127MM, JAW
LENGTH – 25 MM, CIRCLIP SEAL RING CAPACITY – 3~10 MM)
PA0393 RS STOCK NO: 541-6781 (OLD STOCK NO: 185-2773)-J01

REMARKS:

1. DIMENSIONS, HANDLE SPIN, RETAINING TESTS, PERMANENT AND HUMIDITY MEET
DIN- STANDARD. (FORM A TYPE)