

Mounting frame - VS-SI-EB-EMV-2 - 1656495

Please be informed that the data shown in this PDF Document is generated from our Online Catalog. Please find the complete data in the user's documentation. Our General Terms of Use for Downloads are valid (<http://phoenixcontact.com/download>)

Mounting frame, for two front plates or sockets, metal frame, matt nickel-plated, electrically conductive, transparent cover



Key Commercial Data

| | |
|--------------|---------------|
| Packing unit | 1 STK |
| GTIN | |
| GTIN | 4046356029865 |

Technical data

Dimensions

| | |
|-------------------------------|--------|
| Height | 35 mm |
| Width | 130 mm |
| Length | 120 mm |
| Length of the assembly cutout | 91 mm |
| Width of the assembly cutout | 117 mm |

Ambient conditions

| | |
|--------------------------------------|------------------|
| Degree of protection of housing (IP) | IP65 |
| Ambient temperature (operation) | -10 °C ... 60 °C |

General

| | |
|--|--|
| Note | With lockable pressure lock |
| Type | For 2 front plates |
| Color | transparent |
| Housing material | Zinc alloy |
| Housing surface material | Nickel-plated |
| Flammability rating according to UL 94 | V0 |
| Assembly instructions | Suitable for panel thicknesses 1 mm ... 5 mm |

Mounting frame - VS-SI-EB-EMV-2 - 1656495

Technical data

Standards and Regulations

| | |
|--|----|
| Flammability rating according to UL 94 | V0 |
|--|----|

Environmental Product Compliance

| | |
|------------|---|
| REACH SVHC | Lead 7439-92-1 |
| China RoHS | Environmentally Friendly Use Period = 50 |
| | For details about hazardous substances go to tab "Downloads", Category "Manufacturer's declaration" |

Drawings

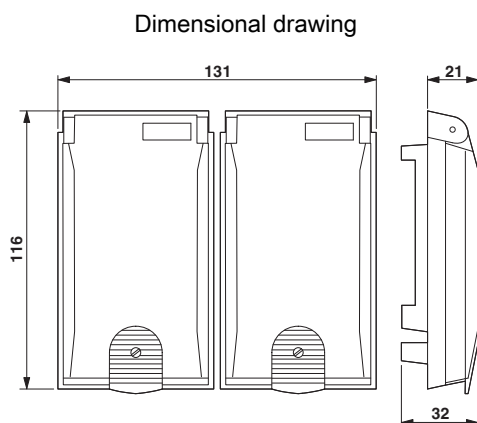

Dimensional drawing

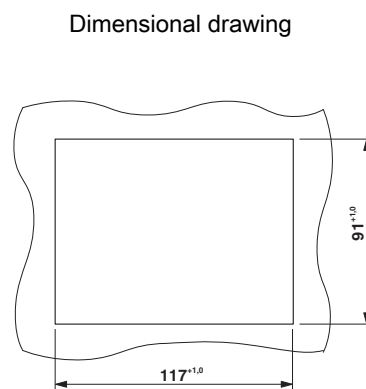

Mounting cutout

Phoenix Contact 2018 © - all rights reserved
<http://www.phoenixcontact.com>

PHOENIX CONTACT GmbH & Co. KG
 Flachsmarktstr. 8
 32825 Blomberg
 Germany
 Tel. +49 5235 300
 Fax +49 5235 3 41200
<http://www.phoenixcontact.com>