



Main

Range of product	Lexium 23 Plus
Product or component type	Motion servo drive
Device short name	LXM23

Complementary

Format of the drive	Book
Phase	3 phases Single phase
[Us] rated supply voltage	220 V (- 10...15 %) single phase 220 V (- 20...15 %) 3 phases
Supply voltage limits	200...255 V single phase 170...255 V 3 phases
Supply frequency	50/60 Hz (- 5...5 %)
Network frequency limits	47.5...63 Hz
Continuous output current	0.9 A
Continuous power	100 Wat 220 V
Nominal power	0.1 kWat 220 V
Leakage current	> 3.5 mA
Output voltage	<= power supply voltage
Electrical isolation	Between power and control
Type of cable	Twisted shielded pairs cable (single or double)at 32...131 °F (0...55 °C)
Electrical connection	Terminal 1.3 mm ² / AWG 16 (L1-L2) Terminal 2.1 mm ² / AWG 14 (R, S, T) Terminal 0.82 mm ² / AWG 18 (U, V, W) Terminal 2.1 mm ² / AWG 14 (PA+, PBe)
Tightening torque	12.39 lbf.in (1.4 N.m) (PE (ground))
Discrete input number	8 programmable
Discrete input type	Programmable (CN1)
Discrete input voltage	12...24 V DC logic
Discrete input logic	Positive or negative logic (CN1)
Discrete output number	5
Discrete output type	(CN1) logic output 12...24 V DC
Discrete output voltage	12...24 V DC
Analogue input number	2
Absolute accuracy error	0.01 %
Analogue input type	Voltage analog input (T_REF) - 10...10 V input impedance: 10 kOhm Voltage analog input (V_REF) - 10...10 V input impedance: 10 kOhm
Control signal type	Servo motor encoder feedback
Protection type	Against reverse polarity inputs signal Against short-circuits outputs signal Overcurrent motor Overvoltage motor Undervoltage motor Overheating motor Overload motor

The information provided in this documentation contains general descriptions and/or technical characteristics of the products contained herein. This documentation is not intended as a substitute for and is not to be used for determining suitability or reliability of these products for specific user applications. It is the duty of any such user or integrator to perform the appropriate and complete risk analysis, evaluation and testing of the products with respect to the relevant specific application or use thereof. Neither Schneider Electric Industries SAS nor any of its affiliates or subsidiaries shall be responsible or liable for misuse of the information contained herein.

	Overspeed motor Abnormal pulse control command drive
Communication interface	Integrated CANopen Integrated CANmotion
Connector type	RJ45 (CN3) CANopen, CANopen Motionbus
Method of access	Slave
Physical interface	2-wire RS485 multidrop Modbus
Transmission rate	125 kbps - for bus length of > 820.21...1640.42 ft (> 250...500 m)for CANopen, CANmotion 250 kbps - for bus length of > 328.08...820.21 ft (> 100...250 m)for CANopen, CANmotion 500 kbps - for bus length of > 13.12...328.08 ft (> 4...100 m)for CANopen, CANmotion 1 Mbps - for bus length of <= 13.12 ft (4 m)for CANopen, CANmotion
Number of addresses	1...127, addresses for CANopen, CANmotion
Status LED	1 LED function: charge LED
Signalling function	Servo status and fault codes five 7-segment display units
Marking	CE
Type of cooling	Natural convection
Operating position	Vertical
Width	2.36 in (60 mm)
Height	6.38 in (162 mm)
Depth	5.75 in (146 mm)
Product weight	3.75 lb(US) (1.7 kg)

Environment

EMC filter	Without EMC filter
electromagnetic compatibility	EMC immunity with additional EMC filter conforming to EN/IEC 61800-3 environments 1 and 2 EMC immunity (level 3) conforming to EN/IEC 61000-4-2 EMC immunity (level 3) conforming to EN/IEC 61000-4-3 EMC immunity (level 3) conforming to EN/IEC 61000-4-5 EMC immunity (level 4) conforming to EN/IEC 61000-4-4 Conducted and radiated emissions with additional EMC filter conforming to EN/IEC 61800-3 environments 1 and 2 category C2, C3
standards	EN/IEC 61800-5-1
product certifications	C-Tick CULus 508
IP degree of protection	IP20 on upper part without protective cover IP41 on upper part with protective cover
vibration resistance	0.075 mm peak to peak (f = 10...57 Hz) conforming to IEC 60068-2-6 1 gn (f = 57...150 Hz) conforming to IEC 60068-2-6
shock resistance	15 gn 11 ms conforming to IEC 60068-2-27
relative humidity	Class 3K3 (5 to 85 %) without condensation or dripping water conforming to IEC 60721-3-3
ambient air temperature for operation	32...131 °F (0...55 °C) conforming to UL
ambient air temperature for storage	-4...149 °F (-20...65 °C)
operating altitude	<= 3280.84 ft (1000 m) without derating > 3280.84...6561.68 ft (> 1000...2000 m) with continuous power derating of 1 % per 100 m

Offer Sustainability

Green Premium product	Green Premium product
Compliant - since 0943 - Schneider Electric declaration of conformity	Compliant - since 0943 - Schneider Electric declaration of conformity
Reference not containing SVHC above the threshold	Reference not containing SVHC above the threshold
Available	Available

Contractual warranty

Warranty period	18 months
-----------------	-----------

Dimensions

$\frac{\text{mm}}{\text{in.}}$

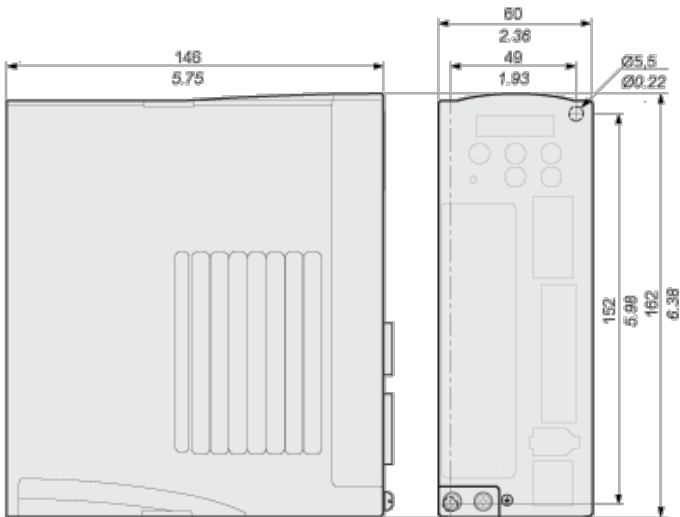

Mounting Recommendations

Mount the device in a vertical position ($\pm 10^\circ$). This is required for cooling the device.

Clearance

Many Devices in a cabinet

$\frac{\text{mm}}{\text{in.}}$

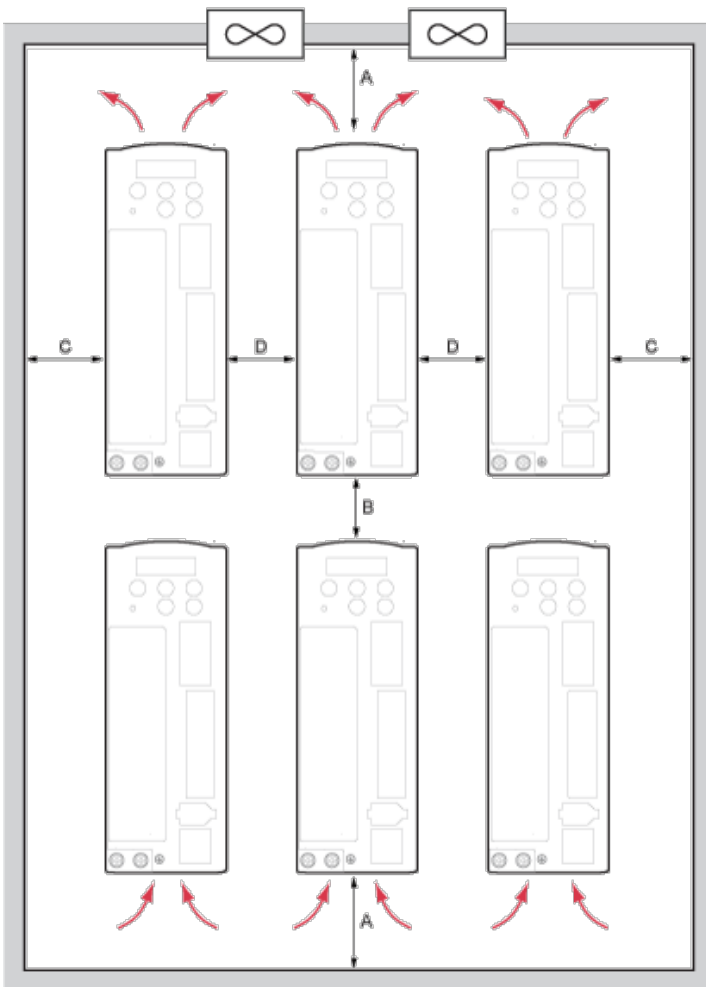

$A \geq 100 \text{ mm} (\geq 4 \text{ in.})$ Free space above/below devices

$B \geq 80 \text{ mm} (\geq 3.2 \text{ in.})$ Free space between devices

C ≥ 40 mm (≥ 1.6 in.)	Free space between devices and cabinet
D ≥ 10 mm (≥ 0.4 in.)	Free space between devices

One Device in a cabinet

$\frac{\text{mm}}{\text{in.}}$

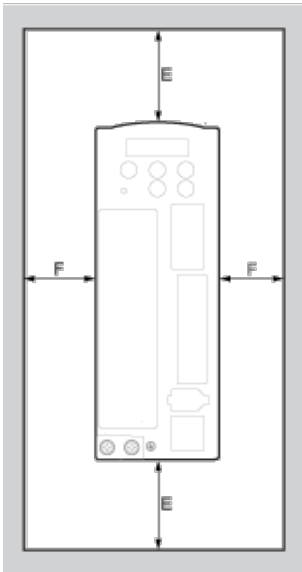

E ≥ 50 mm (≥ 2 in.)	Free space above/below the device
F ≥ 20 mm (≥ 0.8 in.)	Free space between device and cabinet

Position Control Mode Wiring Diagram (Pulse Control)

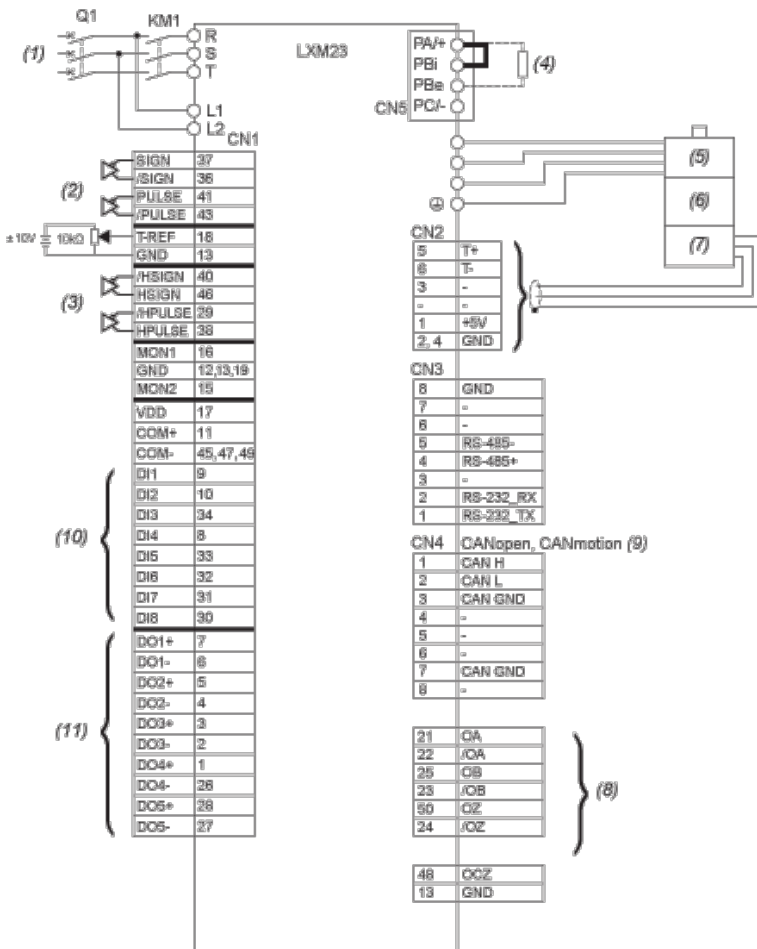

KM1 Line Contactor

Q1 Circuit breaker

(1) AC 220 / 230 V Single Phase or Three Phase 50 / 60 Hz

- (2) Pulse Input (Line Driver)
- (3) High-Speed Pulse Input (Line Receiver)
- (4) External Braking Resistor
- (5) Power Supply
- (6) Holding Brake
- (7) Encoder
- (8) Encoder Pulse Output
- (9) Only LXM23A models
- (10) Digital inputs
- (11) Digital outputs

Position Control Mode Wiring Diagram (Build-In Motion Sequence)

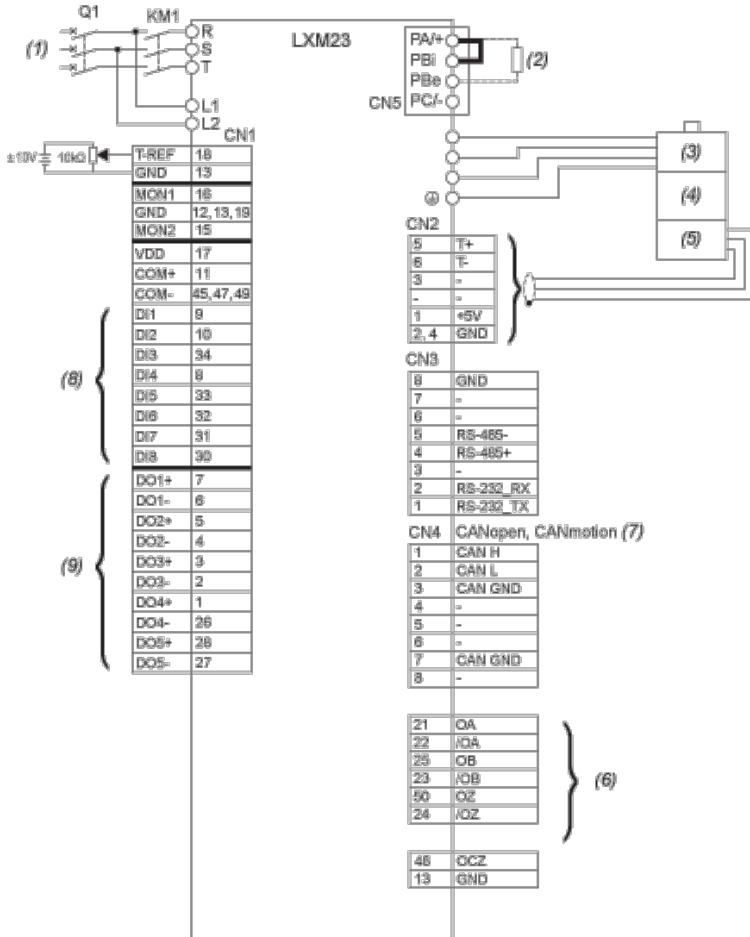

KM1 Line Contactor

Q1 Circuit breaker

- (1) AC 220 / 230 V Single Phase or Three Phase 50 / 60 Hz
- (2) External Braking Resistor
- (3) Power Supply
- (4) Holding Brake
- (5) Encoder
- (6) Encoder Pulse Output
- (7) Only LXM23A models
- (8) Digital inputs
- (9) Digital outputs

Speed Control Mode Wiring Diagram

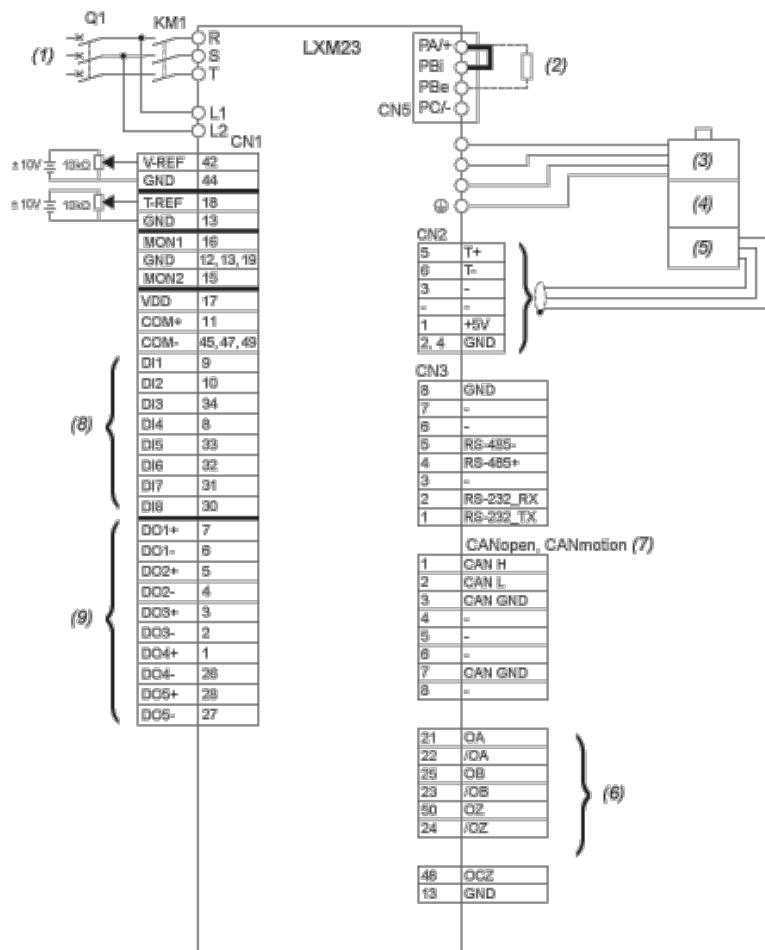

KM1 Line Contactor

Q1 Circuit breaker

(1) AC 220 / 230 V Single Phase or Three Phase 50 / 60 Hz

(2) External Braking Resistor

(3) Power Supply

(4) Holding Brake

(5) Encoder

(6) Encoder Pulse Output

(7) Only LXM23A models

(8) Digital inputs

(9) Digital outputs

Torque Control Mode Wiring Diagram

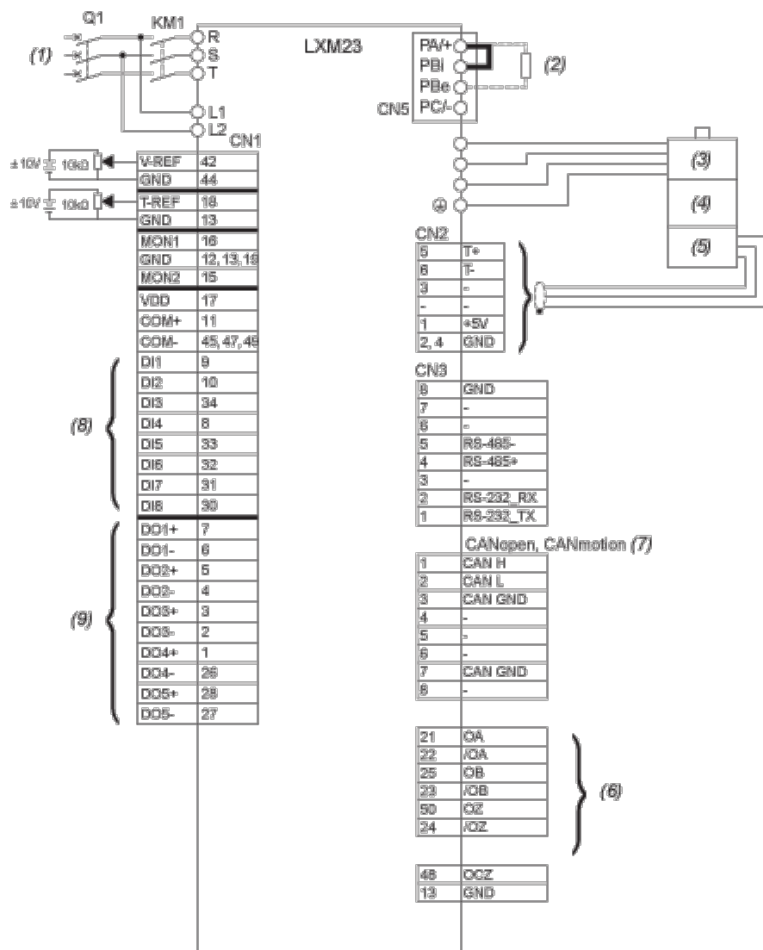

KM1 Line Contactor

Q1 Circuit breaker

(1) AC 220 / 230 V Single Phase or Three Phase 50 / 60 Hz

(2) External Braking Resistor

(3) Power Supply

(4) Holding Brake

(5) Encoder

(6) Encoder Pulse Output

(7) Only LXM23A models

(8) Digital inputs

(9) Digital outputs

CANopen Control Mode Wiring Diagram

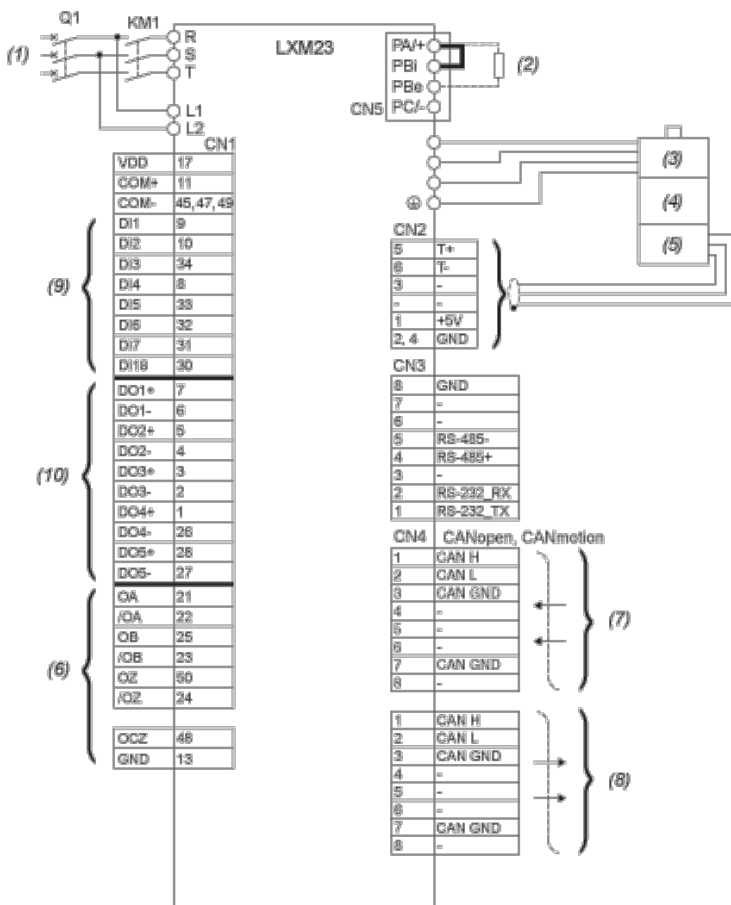

KM1 Line Contactor

Q1 Circuit breaker

(1) AC 220 / 230 V Single Phase or Three Phase 50 / 60 Hz

(2) External Braking Resistor

(3) Power Supply

(4) Holding Brake

(5) Encoder

(6) Encoder Pulse Output

(7) Data Input

(8) Data Output

(9) Digital inputs

(10) Digital outputs